

### DESCRIPTION

The MP2467 is a high frequency step-down switching regulator with integrated internal high-side, high voltage power MOSFET. It provides 2.5A output with current mode control for fast loop response and easy compensation.

The wide 6V to 36V input range accommodates a variety of step-down applications, including those in automotive systems. A 100 $\mu$ A operational quiescent current allows use in battery-powered applications.

High power conversion efficiency over a wide load range is achieved by scaling down the switching frequency at light load condition to reduce the switching and gate driving losses.

The frequency foldback prevents inductor current runaway during startup and thermal shutdown provides reliable, fault tolerant operation.

The MP2467 is available in thermally enhanced SOIC8 package.

### EVALUATION BOARD REFERENCE

Board Number	Dimensions
EV2467DN-00A	1.8"X x 1.8"Y x 0.4"Z

### FEATURES

- 100 $\mu$ A Quiescent Current
- Wide 6V to 36V Operating Input Range
- 150m $\Omega$  Internal Power MOSFET
- 500kHz Fixed Switching Frequency
- Ceramic Capacitor Stable
- Internal Soft-Start
- Precision Current Limit without a Current Sensing Resistor
- Up to 95% Efficiency
- Output Adjustable from 0.8V to 30V
- Available in SOIC8 with Exposed Pad Packages

### APPLICATIONS

- Game Machines
- Automotive Systems
- Industrial Power Systems
- Distributed Power Systems
- Printer Systems
- Battery Powered Systems

All MPS parts are lead-free and adhere to the RoHS directive. For MPS green status, please visit MPS website under Quality Assurance. "MPS" and "The Future of Analog IC Technology" are Registered Trademarks of Monolithic Power Systems, Inc.

### TYPICAL APPLICATION

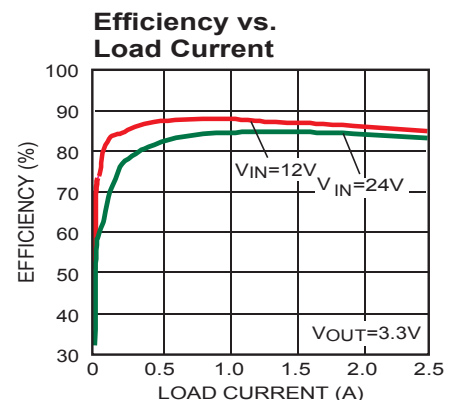
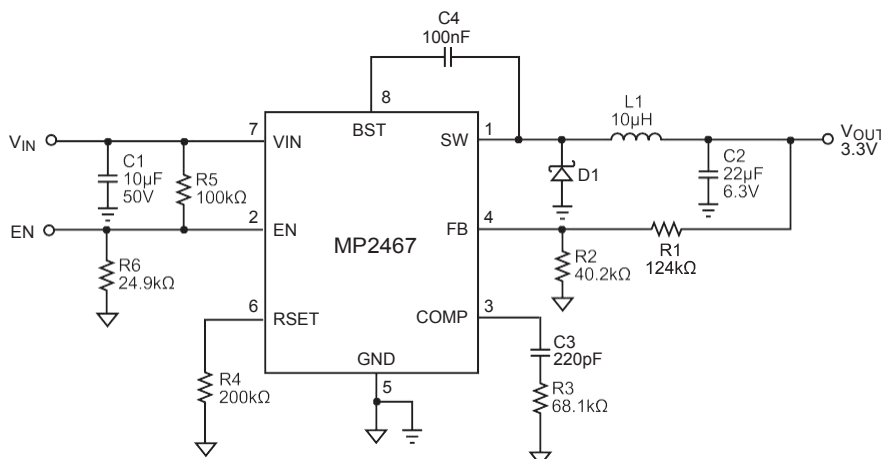

## ORDERING INFORMATION

Part Number*	Package	Top Marking	Free Air Temperature (T <sub>A</sub> )
MP2467DN	SOIC8E	MP2467DN	–40°C to +85°C

\* For Tape & Reel, add suffix –Z (e.g. MP2467DN–Z);  
 For RoHS compliant packaging, add suffix –LF; (e.g. 2467DN–LF–Z)

## PACKAGE REFERENCE

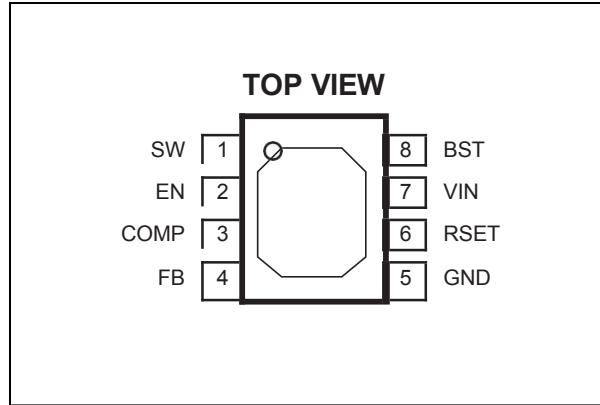

### ABSOLUTE MAXIMUM RATINGS <sup>(1)</sup>

Supply Voltage (V <sub>IN</sub> ).....	V to 40V
Switch Voltage (V <sub>SW</sub> ).....	V to V <sub>IN</sub> + 0.3V
BST to SW.....	V to +5V
All Other Pins.....	V to +5V
Continuous Power Dissipation (T <sub>A</sub> = +25°C) <sup>(2)</sup> .....	2.5W
Junction Temperature.....	150°C
Lead Temperature.....	260°C
Storage Temperature.....	65°C to +150°C

### Recommended Operating Conditions <sup>(3)</sup>

Supply Voltage V <sub>IN</sub> .....	V to 36V
Output Voltage V <sub>OUT</sub> .....	V to 30V
Operating Junct. Temp (T <sub>J</sub> ).....	40°C to +125°C

<i>Thermal Resistance</i> <sup>(4)</sup>	$\theta_{JA}$	$\theta_{JC}$	
SOIC8E .....	50	10...	°C/W

**Notes:**

- 1) Exceeding these ratings may damage the device.
- 2) The maximum allowable power dissipation is a function of the maximum junction temperature T<sub>J</sub>(MAX), the junction-to-ambient thermal resistance  $\theta_{JA}$ , and the ambient temperature T<sub>A</sub>. The maximum allowable continuous power dissipation at any ambient temperature is calculated by P<sub>o</sub>(MAX)=(T<sub>J</sub>(MAX)-T<sub>A</sub>)/  $\theta_{JA}$ . Exceeding the maximum allowable power dissipation will cause excessive die temperature, and the regulator will go into thermal shutdown. Internal thermal shutdown circuitry protects the device from permanent damage.
- 3) The device is not guaranteed to function outside of its operating conditions.
- 4) Measured on JESD51-7, 4-layer PCB.

## ELECTRICAL CHARACTERISTICS

$V_{IN} = 12V$ ,  $V_{EN} = 2.5V$ ,  $V_{COMP} = 1.4V$ ,  $T_A = +25^\circ C$ , unless otherwise noted.

Parameter	Symbol	Condition	Min	Typ	Max	Units
Feedback Voltage	$V_{FB}$	$6V < V_{IN} < 36V$	0.776	0.8	0.824	V
Upper Switch On Resistance	$R_{DS(ON)}$	$V_{BST} - V_{SW} = 5V$		150		m $\Omega$
Upper Switch Leakage		$V_{EN} = 0V$ , $V_{SW} = 0V$		1		$\mu A$
Current Limit			2.9	3.5		A
COMP To Current Sense Transconductance	$G_{CS}$			6		A/V
Error Amp Voltage Gain <sup>(5)</sup>				200		V/V
Error Amp Transconductance		$I_{COMP} = \pm 3\mu A$	40	60	80	$\mu A/V$
Error Amp Min Source current		$V_{FB} = 0.7V$		5		$\mu A$
Error Amp Min Sink current		$V_{FB} = 0.9V$		-5		$\mu A$
VIN UVLO Threshold			2.7	3.0	3.3	V
VIN UVLO Hysteresis				0.35		V
Soft-Start Time <sup>(5)</sup>		$0V < V_{FB} < 0.8V$		1.5		ms
Oscillator Frequency			400	500	600	KHz
Minimum Switch On Time <sup>(5)</sup>				100		ns
Shutdown Supply Current		$V_{EN} = 0V$		12	20	$\mu A$
Quiescent Supply Current		No load, $V_{FB} = 0.9V$		100	125	$\mu A$
Thermal Shutdown				150		$^\circ C$
Thermal Shutdown Hysteresis				15		$^\circ C$
EN Up Threshold			1.35	1.5	1.65	V
EN Down Threshold			1.15	1.2	1.25	V
Minimum Off Time <sup>(5)</sup>				200		ns

**Note:**

5) Guaranteed by design.

## PIN FUNCTIONS

Pin #	Name	Description
1	SW	Switch Node. This is the output from the high-side switch. A low $V_f$ Schottky rectifier to ground is required. The rectifier must be close to the SW pins to reduce switching spikes.
2	EN	Enable Input. Pulling this pin below the specified threshold shuts the chip down. Pulling it above the specified threshold or leaving it floating enables the chip.
3	COMP	Compensation. This node is the output of the error amplifier. Control loop frequency compensation is applied to this pin.
4	FB	Feedback. This is the input to the error amplifier. An external resistive divider connected between the output and GND is compared to the internal +0.8V reference to set the regulation voltage.
5	GND	Ground. It should be connected as close as possible to the output capacitor avoiding the high current switch paths.
6	RSET	Internal Bias Setting. Connect a 200k $\Omega$ resistor to this pin.
7	VIN	Input Supply. This supplies power to all the internal control circuitry, including bootstrap regulator and the high-side switch. A decoupling capacitor to ground must be placed close to this pin to minimize switching spikes.
8	BST	Bootstrap. This is the positive power supply for the internal floating high-side MOSFET driver. Connect a bypass capacitor between this pin and SW pin.

## TYPICAL PERFORMANCE CHARACTERISTICS

$V_{IN} = 12V$ ,  $C1 = 10\mu F$ ,  $C2 = 22\mu F$ ,  $L = 10\mu H$  and  $T_A = +25^\circ C$ , unless otherwise noted.

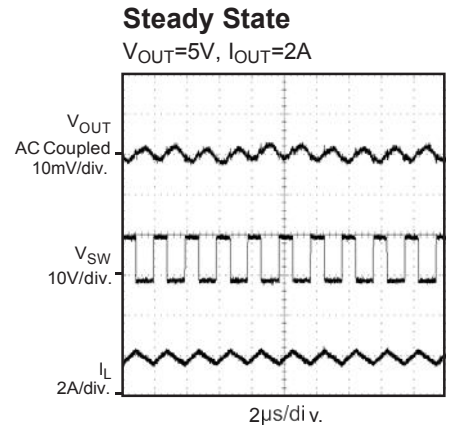
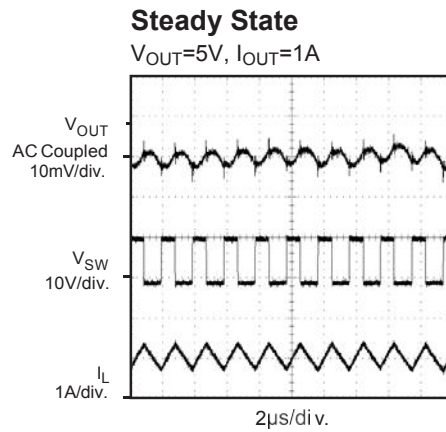
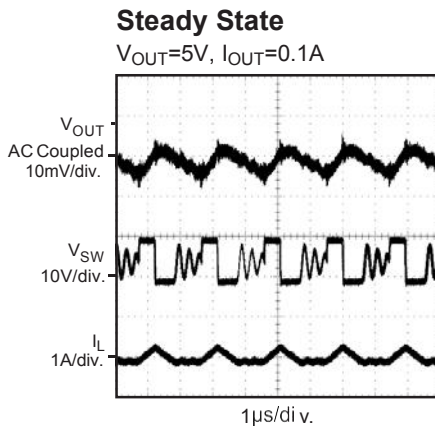
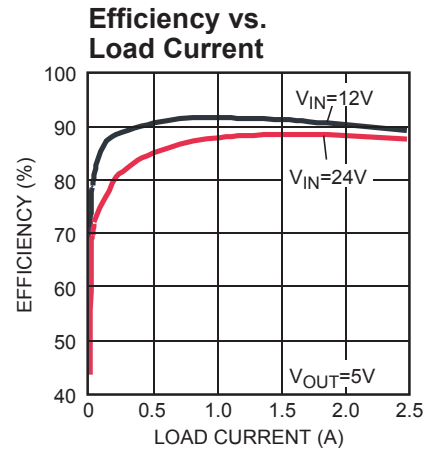
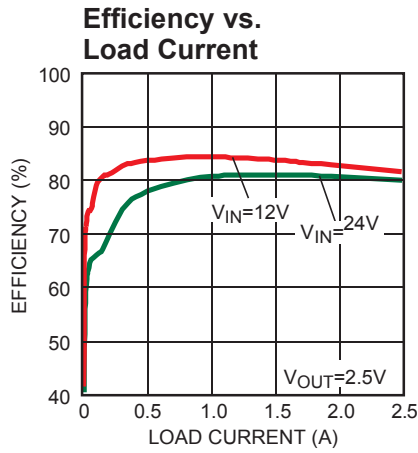

**TYPICAL PERFORMANCE CHARACTERISTICS (continued)**
 $V_{IN} = 12V$ ,  $C1 = 10\mu F$ ,  $C2 = 22\mu F$ ,  $L = 10\mu H$  and  $T_A = +25^\circ C$ , unless otherwise noted.

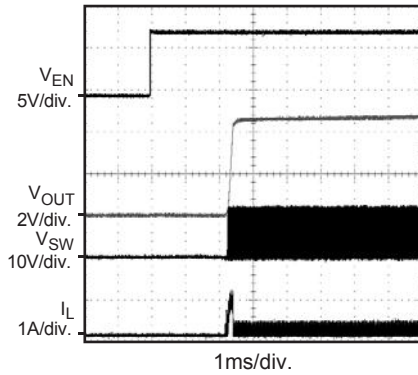
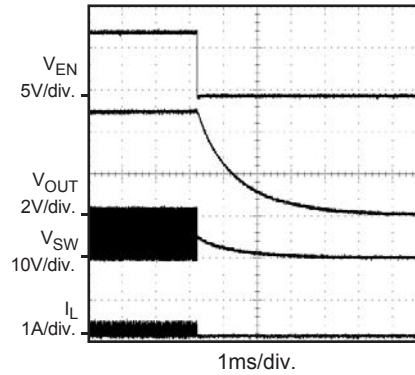
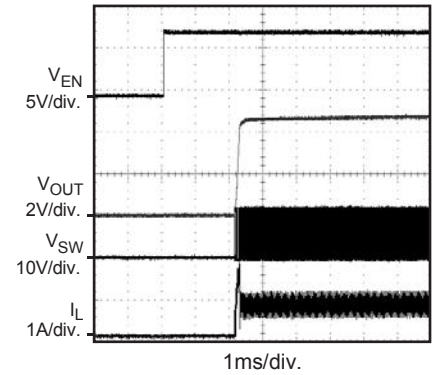
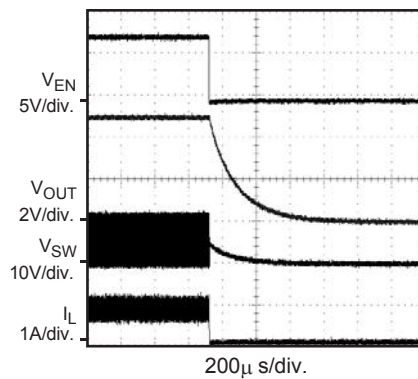
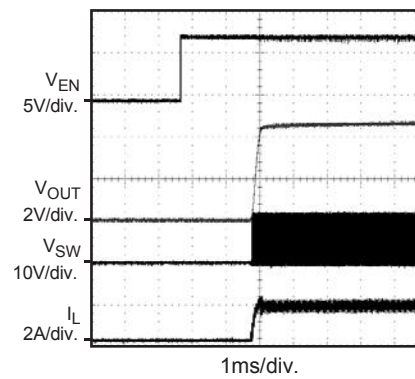
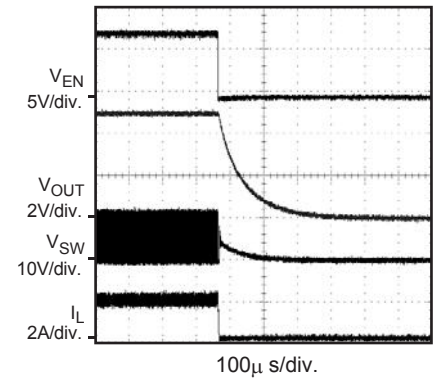
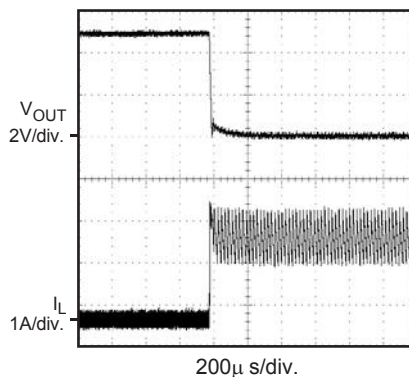
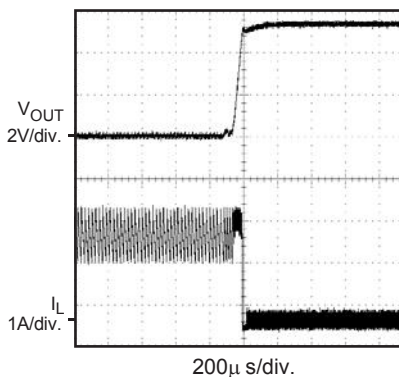
**Startup**
 $V_{OUT} = 5V$ ,  $I_{OUT} = 0.1A$ 

**Shutdown**
 $V_{OUT} = 5V$ ,  $I_{OUT} = 0.1A$ 

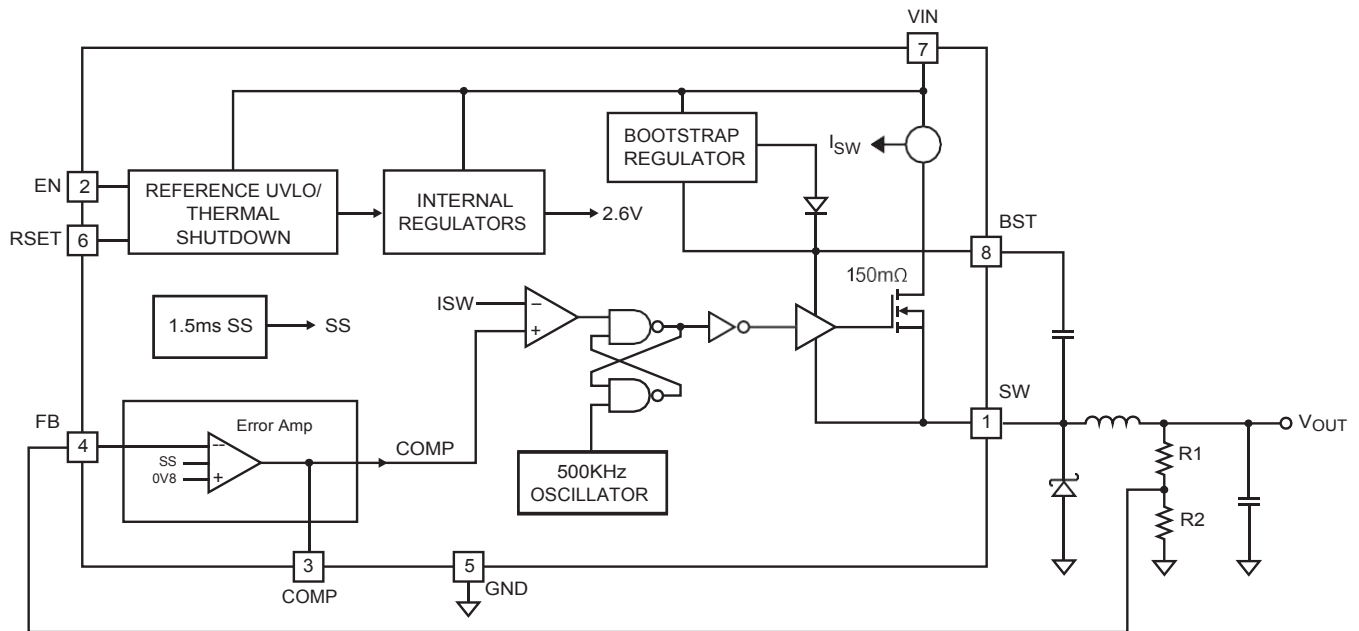
**Startup**
 $V_{OUT} = 5V$ ,  $I_{OUT} = 1A$ 

**Shutdown**
 $V_{OUT} = 5V$ ,  $I_{OUT} = 1A$ 

**Startup**
 $V_{OUT} = 5V$ ,  $I_{OUT} = 2A$ 

**Shutdown**
 $V_{OUT} = 5V$ ,  $I_{OUT} = 2A$ 

**Short Circuit Entry**
 $V_{OUT} = 5V$ ,  $I_{OUT} = 0.1A$  to Short

**Short Circuit Recovery**
 $V_{OUT} = 5V$ ,  $I_{OUT} = \text{Short to } 0.1A$ 

## BLOCK DIAGRAM



**Figure 1—Functional Block Diagram**

## OPERATION

The MP2467 is a fixed frequency, non-synchronous, step-down switching regulator with an integrated high-side high voltage power MOSFET. It provides a single highly efficient solution with current mode control for fast loop response and easy compensation. It features a wide input voltage range, internal soft-start control and precision current limiting. Its very low operational quiescent current makes it suitable for battery powered applications.

The MP2467 operates in a fixed frequency, peak current control mode to regulate the output voltage. A PWM cycle is initiated by the internal clock. The power MOSFET is turned on and remains on until its current reaches the value set by the COMP voltage. When the power switch is off, it remains off for at least 200ns before the next cycle starts. If, in one PWM period, the current in the power MOSFET does not reach the COMP set current value, the power MOSFET remains on, saving a turn-off operation.

### Error Amplifier

The error amplifier compares the FB pin voltage with the internal reference (REF) and outputs a current proportional to the difference between the two. This output current is then used to charge or discharge the external compensation network to form the COMP voltage, which is used to control the power MOSFET current.

During operation, the minimum COMP voltage is clamped to 0.9V and its maximum is clamped to 2.0V. COMP is internally pulled down to GND in shutdown mode. COMP should not be pulled above 2.6V.

### Internal Regulator

Most of the internal circuitries are powered from the 2.6V internal regulator. This regulator takes the VIN input and operates in the full VIN range. When VIN is greater than 3.0V, the output of the regulator is in full regulation. When VIN is lower than 3.0V, the output decreases.

### Enable Control

The MP2467 has a dedicated enable control pin (EN). With high enough input voltage, the chip can be enabled and disabled by EN. Its falling threshold is 1.2V, and its rising threshold is 1.5V (300mV higher).

If left open, EN is pulled up to about 3.0V by an internal 1 $\mu$ A current source. To disable the part, EN pin must be pulled down with greater than 2 $\mu$ A current.

### Under-Voltage Lockout (UVLO)

Under-voltage lockout (UVLO) is implemented to protect the chip from operating at insufficient supply voltage. The UVLO rising threshold is about 3.0V while its falling threshold is a consistent 2.6V.

### Internal Soft-Start

The soft-start is implemented to prevent the converter output voltage from overshooting during startup. When the chip starts, the internal circuitry generates a soft-start voltage (SS) ramping up from 0V to 2.6V. When it is lower than the internal reference (REF), SS overrides REF so the error amplifier uses SS as the reference. When SS is higher than REF, REF regains control.

### Thermal Shutdown

Thermal shutdown is implemented to prevent the chip from operating at exceedingly high temperatures. When the silicon die temperature is higher than its upper threshold, it shuts down the whole chip. When the temperature is lower than its lower threshold, the chip is enabled again.

### Floating Driver and Bootstrap Charging

The floating power MOSFET driver is powered by an external bootstrap capacitor. This floating driver has its own UVLO protection. This UVLO's rising threshold is 2.2V with a hysteresis of 150mV.

At higher duty cycle operation condition, the time period available to the bootstrap charging may be too short to sufficiently recharge the bootstrap capacitor.

In case the internal circuit does not have sufficient voltage and the bootstrap capacitor is not charged, extra external circuitry can be used to ensure the bootstrap voltage is in the normal operational region.

The DC quiescent current of the floating driver is about 20 $\mu$ A. Make sure the bleeding current at the SW node is higher than this value, such that:

$$I_o + \frac{V_o}{(R1+R2)} > 20\mu A$$

### **Current Comparator and Current Limit**

The power MOSFET current is accurately sensed via a current sense MOSFET. It is then fed to the high speed current comparator for the current mode control purpose. The current comparator takes this sensed current as one of its inputs. When the power MOSFET is turned on, the comparator is first blanked till the end of the turn-on transition to avoid noise issues. The comparator then compares the power switch current with the COMP voltage. When the sensed current is higher than the COMP voltage, the comparator output is low, turning off the power MOSFET. The cycle-by-cycle maximum current of the internal power MOSFET is internally limited.

### **Startup and Shutdown**

If both VIN and EN are higher than their appropriate thresholds, the chip starts. The reference block starts first, generating stable

reference voltage and currents, and then the internal regulator is enabled. The regulator provides stable supply for the remaining circuitries.

While the internal supply rail is up, an internal timer holds the signaling path of the power MOSFET turn-on at OFF for about 50 $\mu$ s to blank the startup glitches. When the internal soft-start block is enabled, it first holds its SS output low to ensure the remaining circuitries are ready and then slowly ramps up.

Three events can shut down the chip: EN low, VIN low and thermal shutdown. In the shutdown procedure, the signaling path is first blocked to avoid any fault triggering. The COMP voltage and the internal supply rail are then pulled down. The floating driver is not subject to this shutdown command.

## APPLICATION INFORMATION

### COMPONENT SELECTION

#### Setting the Output Voltage

The output voltage is set using a resistive voltage divider from the output voltage to FB pin. The voltage divider divides the output voltage down to the feedback voltage by the ratio:

$$V_{FB} = V_{OUT} \frac{R2}{R1 + R2}$$

Thus the output voltage is:

$$V_{OUT} = V_{FB} \frac{(R1 + R2)}{R2}$$

A few  $\mu$ A current from high side BS circuitry can be seen at the output when the MP2467 is at no load. In order to absorb this small amount of current, keep R2 under 40K $\Omega$ . A typical value for R2 can be 40.2k $\Omega$ . With this value, R1 can be determined by:

$$R1 = 50.25 \times (V_{OUT} - 0.8)(k\Omega)$$

For example, for a 3.3V output voltage, R2 is 40.2k $\Omega$ , and R1 is 127k $\Omega$ .

#### Inductor

The inductor is required to supply constant current to the output load while being driven by the switched input voltage. A larger value inductor will result in less ripple current that will result in lower output ripple voltage. However, the larger value inductor will have a larger physical size, higher series resistance, and/or lower saturation current.

A good rule for determining the inductance to use is to allow the peak-to-peak ripple current in the inductor to be approximately 30% of the maximum switch current limit. Also, make sure that the peak inductor current is below the maximum switch current limit. The inductance value can be calculated by:

$$L = \frac{V_{OUT} \left( 1 - \frac{V_{OUT}}{V_{IN}} \right)}{f_s \times \Delta I_L}$$

Where  $V_{OUT}$  is the output voltage,  $V_{IN}$  is the input voltage,  $f_s$  is the switching frequency, and  $\Delta I_L$  is the peak-to-peak inductor ripple current.

Choose an inductor that will not saturate under the maximum inductor peak current. The peak inductor current can be calculated by:

$$I_{LP} = I_{LOAD} + \frac{V_{OUT}}{2 \times f_s \times L} \left( 1 - \frac{V_{OUT}}{V_{IN}} \right)$$

Where  $I_{LOAD}$  is the load current.

Table 1 lists a number of suitable inductors from various manufacturers. The choice of which style inductor to use mainly depends on the price vs. size requirements and any EMI requirement.

**Table 1—Inductor Selection Guide**

Part Number	Inductance (μH)	Max DCR (Ω)	Current Rating (A)	Dimensions L x W x H (mm <sup>3</sup> )
<b>Würth Electronics</b>				
7447789002	2.2	0.019	4	7.3x7.3x3.2
7447789003	3.3	0.024	3.42	7.3x7.3x3.2
7447789004	4.7	0.033	2.9	7.3x7.3x3.2
744066100	10	0.035	3.6	10x10x3.8
744771115	15	0.025	3.75	12x12x6
744771122	22	0.031	3.37	12x12x6
<b>TDK</b>				
RLF7030T-2R2	2.2	0.012	5.4	7.3x6.8x3.2
RLF7030T-3R3	3.3	0.02	4.1	7.3x6.8x3.2
RLF7030T-4R7	4.7	0.031	3.4	7.3x6.8x3.2
SLF10145T-100	10	0.0364	3	10.1x10.1x4.5
SLF12565T-150M4R2	15	0.0237	4.2	12.5x12.5x6.5
SLF12565T-220M3R5	22	0.0316	3.5	12.5x12.5x6.5
<b>Toko</b>				
FDV0630-2R2M	2.2	0.021	5.3	7.7x7x3
FDV0630-3R3M	3.3	0.031	4.3	7.7x7x3
FDV0630-4R7M	4.7	0.049	3.3	7.7x7x3
919AS-100M	10	0.0265	4.3	10.3x10.3x4.5
919AS-160M	16	0.0492	3.3	10.3x10.3x4.5
919AS-220M	22	0.0776	3	10.3x10.3x4.5

### Output Rectifier Diode

The output rectifier diode supplies the current to the inductor when the high-side switch is off. To reduce losses due to the diode forward voltage and recovery times, use a Schottky diode.

Choose a diode whose maximum reverse voltage rating is greater than the maximum input voltage, and whose current rating is greater than the maximum load current. Table 2 lists example Schottky diodes and manufacturers.

**Table 2—Diode Selection Guide**

Diodes	Voltage/ Current Rating	Manufacturer
B240A-13-F	40V, 2A	Diodes Inc.
B340A-13-F	40V, 3A	Diodes Inc.
CMSH2-40M	40V, 2A	Central Semi
CMSH3-40MA	40V, 3A	Central Semi

### Input Capacitor

The input current to the step-down converter is discontinuous, therefore a capacitor is required to supply the AC current to the step-down converter while maintaining the DC input voltage. Use low ESR capacitors for the best performance. Ceramic capacitors are preferred, but tantalum or low-ESR electrolytic capacitors may also suffice.

Since the input capacitor (C1) absorbs the input switching current it requires an adequate ripple current rating. The RMS current in the input capacitor can be estimated by:

$$I_{C1} = I_{LOAD} \times \sqrt{\frac{V_{OUT}}{V_{IN}} \times \left(1 - \frac{V_{OUT}}{V_{IN}}\right)}$$

The worse case condition occurs at  $V_{IN} = 2V_{OUT}$ , where:

$$I_{C1} = \frac{I_{LOAD}}{2}$$

For simplification, choose the input capacitor whose RMS current rating greater than half of the maximum load current.

The input capacitor can be electrolytic, tantalum or ceramic. When using electrolytic or tantalum capacitors, a small, high quality ceramic capacitor, i.e. 0.1μF, should be placed as close to the IC as possible. When using ceramic capacitors, make sure that they have enough capacitance to provide sufficient charge to prevent excessive voltage ripple at input. The input voltage ripple caused by capacitance can be estimated by:

$$\Delta V_{IN} = \frac{I_{LOAD}}{f_s \times C_1} \times \frac{V_{OUT}}{V_{IN}} \left( 1 - \frac{V_{OUT}}{V_{IN}} \right)$$

### Output Capacitor

The output capacitor (C2) is required to maintain the DC output voltage. Ceramic, tantalum, or low ESR electrolytic capacitors are recommended. Low ESR capacitors are preferred to keep the output voltage ripple low. The output voltage ripple can be estimated by:

$$\Delta V_{OUT} = \frac{V_{OUT}}{f_s \times L} \times \left( 1 - \frac{V_{OUT}}{V_{IN}} \right) \times \left( R_{ESR} + \frac{1}{8 \times f_s \times C_2} \right)$$

Where L is the inductor value and R<sub>ESR</sub> is the equivalent series resistance (ESR) value of the output capacitor.

In the case of ceramic capacitors, the impedance at the switching frequency is dominated by the capacitance. The output voltage ripple is mainly caused by the capacitance. For simplification, the output voltage ripple can be estimated by:

$$\Delta V_{OUT} = \frac{V_{OUT}}{8 \times f_s \times L \times C_2} \left( 1 - \frac{V_{OUT}}{V_{IN}} \right)$$

In the case of tantalum or electrolytic capacitors, the ESR dominates the impedance at the switching frequency. For simplification, the output ripple can be approximated to:

$$\Delta V_{OUT} = \frac{V_{OUT}}{f_s \times L} \times \left( 1 - \frac{V_{OUT}}{V_{IN}} \right) \times R_{ESR}$$

The characteristics of the output capacitor also affect the stability of the regulation system. The MP2467 can be optimized for a wide range of capacitance and ESR values.

### Compensation Components

MP2467 employs current mode control for easy compensation and fast transient response. The system stability and transient response are controlled through the COMP pin. COMP pin is the output of the internal error amplifier. A series capacitor-resistor combination sets a pole-zero combination to control the characteristics of the control system. The DC gain of the voltage feedback loop is given by:

$$A_{VDC} = R_{LOAD} \times G_{CS} \times A_{VEA} \times \frac{1}{V_c \times FB}$$

Where A<sub>VEA</sub> is the error amplifier voltage gain, 200V/V, G<sub>CS</sub> is the current sense

transconductance, 6A/V; R<sub>LOAD</sub> is the load resistor value.

The system has two poles of importance. One is due to the compensation capacitor (C3), the output resistor of error amplifier. The other is due to the output capacitor and the load resistor. These poles are located at:

$$f_{p1} = \frac{G_{EA}}{2\pi \times C_3 \times A_{VEA}}$$

$$f_{p2} = \frac{1}{2\pi \times C_2 \times R_{LOAD}}$$

Where, G<sub>EA</sub> is the error amplifier transconductance, 60μA/V.

The system has one zero of importance, due to the compensation capacitor (C3) and the compensation resistor (R3). This zero is located at:

$$f_{z1} = \frac{1}{2\pi \times C_3 \times R_3}$$

The system may have another zero of importance, if the output capacitor has a large capacitance and/or a high ESR value. The zero, due to the ESR and capacitance of the output capacitor, is located at:

$$f_{ESR} = \frac{1}{2\pi \times C_2 \times R_{ESR}}$$

In this case (as shown in Figure 2), a third pole set by the compensation capacitor (C6) and the compensation resistor (R3) is used to compensate the effect of the ESR zero on the loop gain. This pole is located at:

$$f_{P3} = \frac{1}{2\pi \times C6 \times R3}$$

The goal of compensation design is to shape the converter transfer function to get a desired loop gain. The system crossover frequency where the feedback loop has the unity gain is important. Lower crossover frequencies result in slower line and load transient responses, while higher crossover frequencies could cause system unstable. A good rule of thumb is to set the crossover frequency to approximately one-tenth of the switching frequency. The Table 3 lists the typical values of compensation components for some standard output voltages with various output capacitors and inductors. The values of the compensation components have been optimized for fast transient responses and good stability at given conditions.

**Table 3—Compensation Values for Typical Output Voltage/Capacitor Combinations at  $V_{IN}=12V$**

$V_{OUT}$ (V)	L ( $\mu H$ )	C2 ( $\mu F$ )	R3 (k $\Omega$ )	C3 (pF)	C6
1.8	4.7	47	105	100	None
2.5	4.7 - 6.8	22	54.9	220	None
3.3	6.8 - 10	22	68.1	220	None
5	10 - 15	22	100	150	None

Note: with the compensation, the control loop has the bandwidth at about 1/10 switching frequency and the phase margin higher than 45 degree.

To optimize the compensation components for conditions not listed in Table 3, the following procedure can be used.

1. Choose the compensation resistor (R3) to set the desired crossover frequency. Determine the R3 value by the following equation:

$$R3 = \frac{2\pi \times C2 \times f_c}{G_{EA} \times G_{CS}} \times \frac{V_{OUT}}{V_{FB}}$$

Where  $f_c$  is the desired crossover frequency.

2. Choose the compensation capacitor (C3) to achieve the desired phase margin. For applications with typical inductor values, setting the compensation zero,  $f_{z1}$ , below one fourth of the crossover frequency provides sufficient phase margin. Determine the C3 value by the following equation:

$$C3 > \frac{4}{2\pi \times R3 \times f_c}$$

3. Determine if the second compensation capacitor (C6) is required. It is required if the ESR zero of the output capacitor is located at less than half of the switching frequency, or the following relationship is valid:

$$\frac{1}{2\pi \times C2 \times R_{ESR}} < \frac{f_s}{2}$$

If this is the case, then add the second compensation capacitor (C6) to set the pole  $f_{P3}$  at the location of the ESR zero. Determine the C6 value by the equation:

$$C6 = \frac{C2 \times R_{ESR}}{R3}$$

### External Bootstrap Diode

It is recommended that an external bootstrap diode be added when the input voltage is no greater than 5V or the 5V rail is available in the system. This helps improve the efficiency of the regulator. The bootstrap diode can be a low cost one such as IN4148 or BAT54.

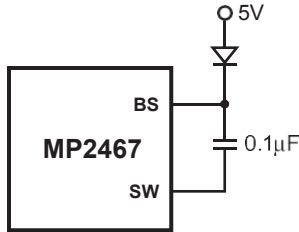

**Figure 2—External Bootstrap Diode**

This diode is also recommended for high duty cycle operation (when  $V_{OUT} / V_{IN} > 65\%$ ) or low  $V_{IN}$  ( $< 5V_{in}$ ) applications.

At no load or light load, the converter may operate in pulse skipping mode in order to maintain the output voltage in regulation. Thus there is less time to refresh the BS voltage. In order to have enough gate voltage under such operating conditions, the difference of  $V_{IN} - V_{OUT}$  should be greater than 3V. For example, if the  $V_{OUT}$  is set to 3.3V, the  $V_{IN}$  needs to be higher than  $3.3V + 3V = 6.3V$  to maintain enough BS voltage at no load or light load. To meet this requirement, EN pin can be used to program the input UVLO voltage to  $V_{out} + 3V$ .

## TYPICAL APPLICATION CIRCUITS

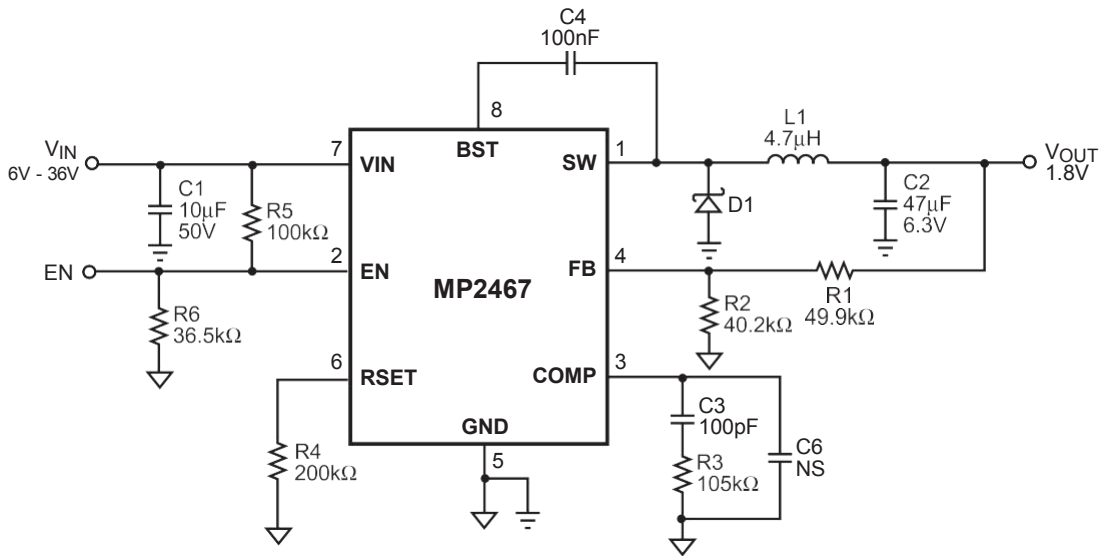

Figure 3—1.8V Output Typical Application Schematic

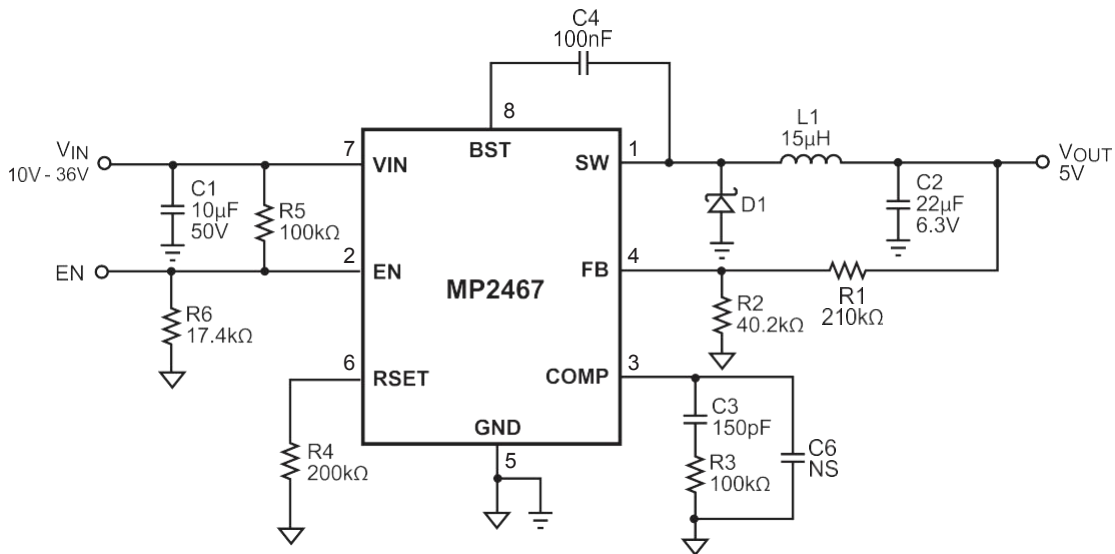

Figure 4—5V Output Typical Application Schematic

## PCB LAYOUT GUIDE

PCB layout is very important to achieve stable operation. It is highly recommended to duplicate EVB layout for optimum performance.

If change is necessary, please follow these guidelines and take Figure 5 for reference.

- 1) Keep the path of switching current short and minimize the loop area formed by Input cap, high-side MOSFET and external switching diode.
- 2) Bypass ceramic capacitors are suggested to be put close to the  $V_{IN}$  Pin.
- 3) Ensure all feedback connections are short and direct. Place the feedback resistors and compensation components as close to the chip as possible.
- 4) Route SW away from sensitive analog areas such as FB.
- 5) Connect IN, SW, and especially GND respectively to a large copper area to cool the chip to improve thermal performance and long-term reliability.

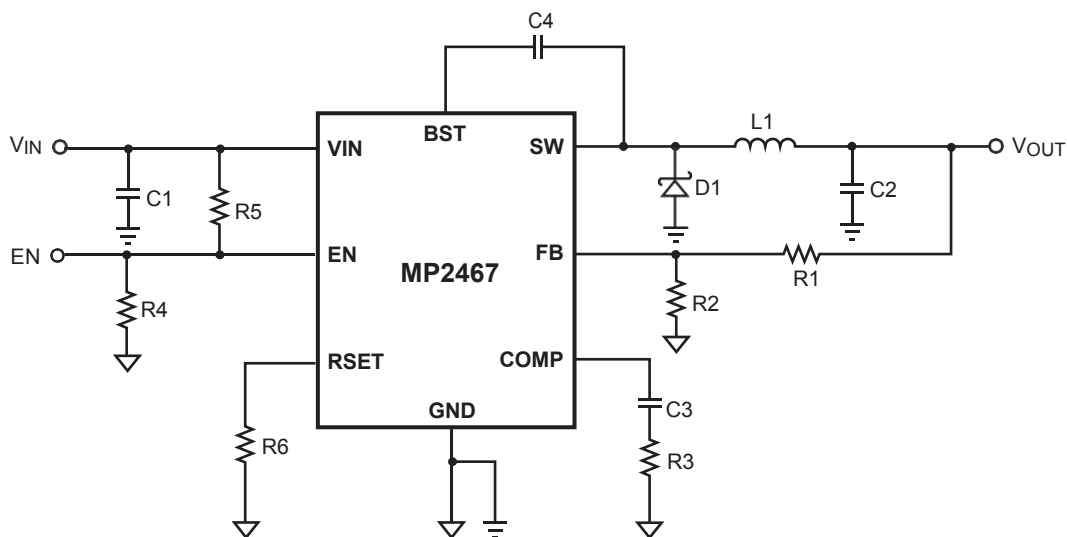

**MP2467 Typical Application Circuit**

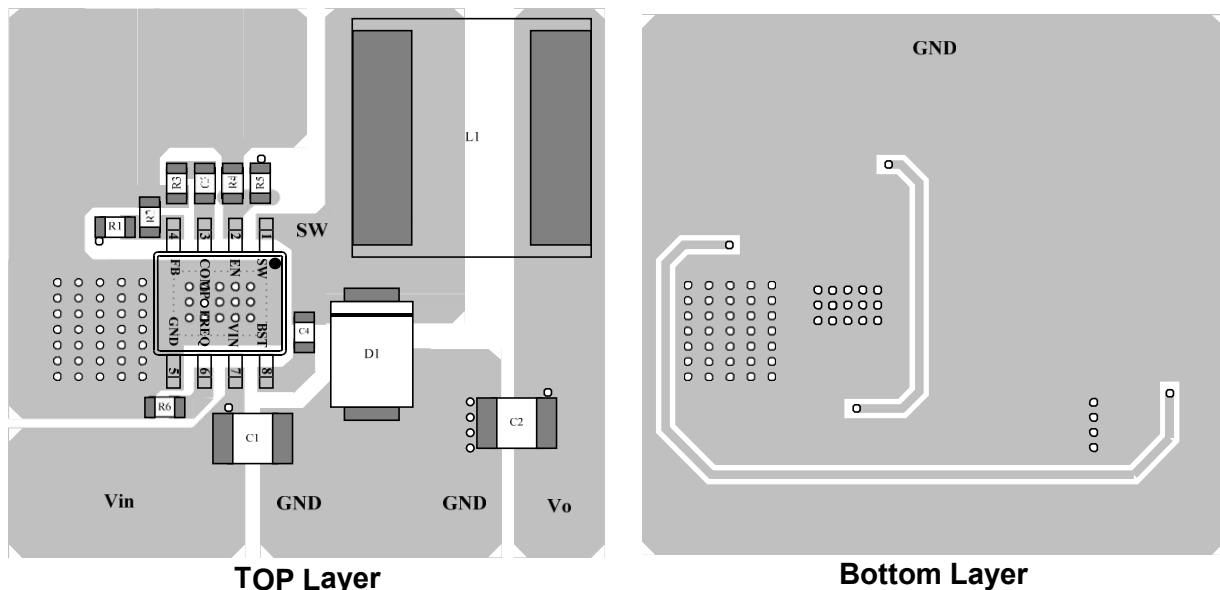

**Figure 5—MP2467 Typical Application Circuit and PCB Layout Guide**

## PACKAGE INFORMATION

### SOIC8E (EXPOSED PAD)

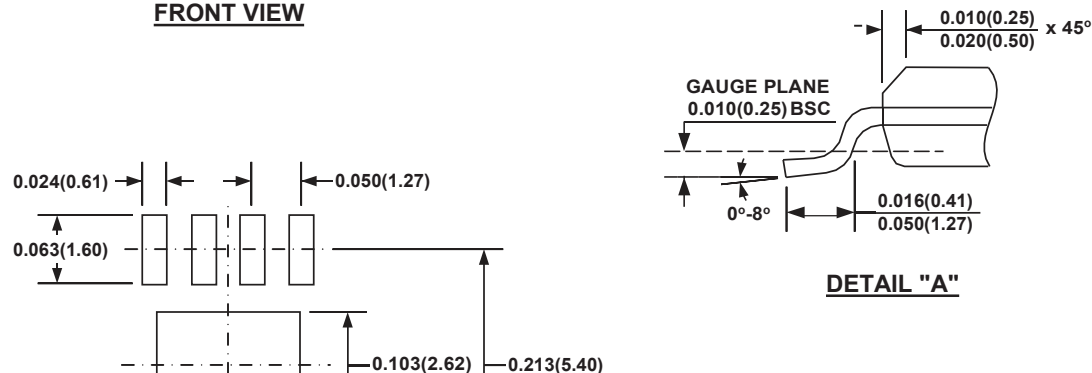
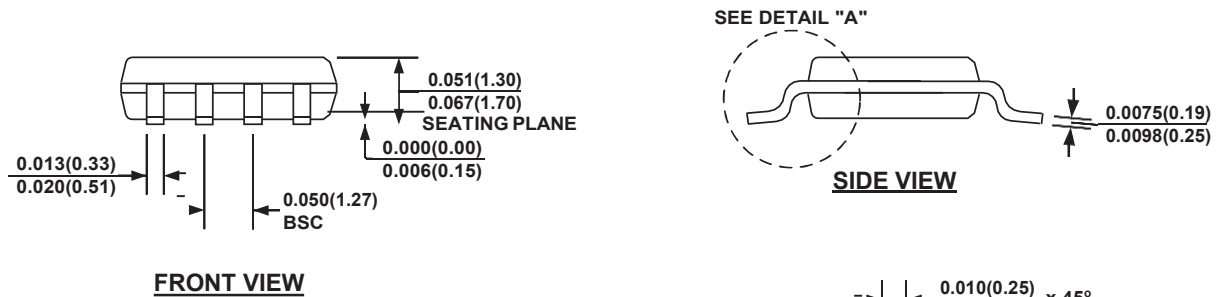
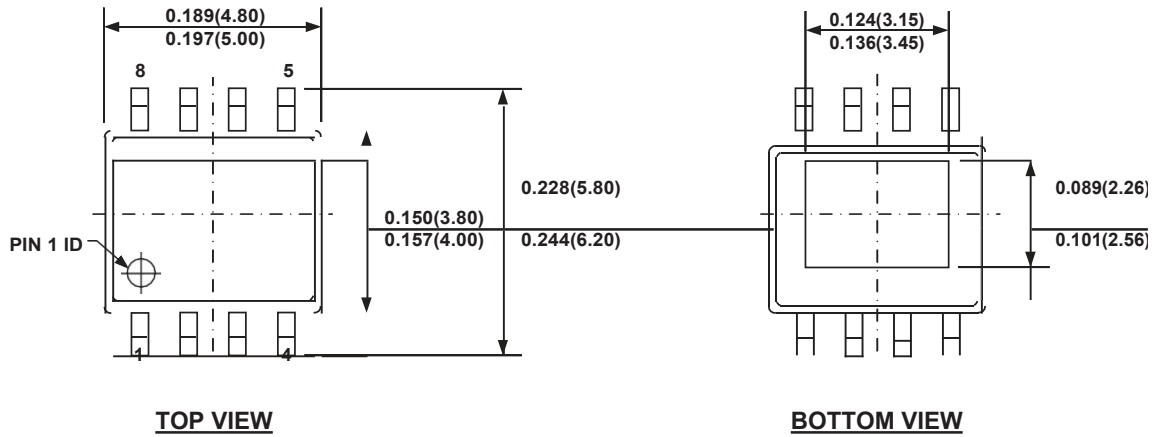

**NOTE:**

- 1) CONTROL DIMENSION IS IN INCHES. DIMENSION IN BRACKET IS IN MILLIMETERS.
- 2) PACKAGE LENGTH DOES NOT INCLUDE MOLD FLASH, PROTRUSIONS OR GATE BURRS.
- 3) PACKAGE WIDTH DOES NOT INCLUDE INTERLEAD FLASH OR PROTRUSIONS.
- 4) LEAD COPLANARITY (BOTTOM OF LEADS AFTER FORMING) SHALL BE 0.004" INCHES MAX.
- 5) DRAWING CONFORMS TO JEDEC MS-012, VARIATION BA.
- 6) DRAWING IS NOT TO SCALE.

**NOTICE:** The information in this document is subject to change without notice. Users should warrant and guarantee that third party Intellectual Property rights are not infringed upon when integrating MPS products into any application. MPS will not assume any legal responsibility for any said applications.