

# MP2128

## 2.5V-6V Input, 3MHz, 1A Synchronous Step-Down Converter

The Future of Analog IC Technology

### DESCRIPTION

The MP2128 is a 3MHz constant frequency, current mode, PWM step-down converter with integrated main switch and synchronous rectifier that is ideal for powering portable equipment that runs from a single Li-Ion or Li-Polymer battery.

The MP2128 can supply up to 1A load current from a 2.5V to 6V input voltage. The output voltage can be as low as 0.6V.

Additional features include  $<1\mu\text{A}$  shutdown current, internal soft-start, cycle-by-cycle over current protection, short circuit protection, and thermal shutdown.

The MP2128 is available in low profile (1.5mm) 5-pin SOT23 and 8-pin, QFN8 2mm $\times$ 2mm packages.

### FEATURES

- High Efficiency: Up to 95%
- 3MHz Constant Switching Frequency
- 1A Available Load Current
- 2.5V to 6V Input Voltage Range
- Output Voltage as Low as 0.6V
- Current Mode Control
- Cycle-by-Cycle Over Current Protection
- Short Circuit Protection
- Thermal Shutdown
- $<1\mu\text{A}$  Shutdown Current
- Internal Soft-Start
- Space Saving 5-Pin SOT23 Package and 8-pin, QFN8 2mm $\times$ 2mm package

### APPLICATIONS

- Cellular Phones
- Microprocessors and DSP Core Supplies
- PDAs and Smart Phones
- MP3 and Portable Media Players
- Digital Still and Video Cameras
- Portable Instruments

"MPS" and "The Future of Analog IC Technology" are Registered Trademarks of Monolithic Power Systems, Inc.

### TYPICAL APPLICATION

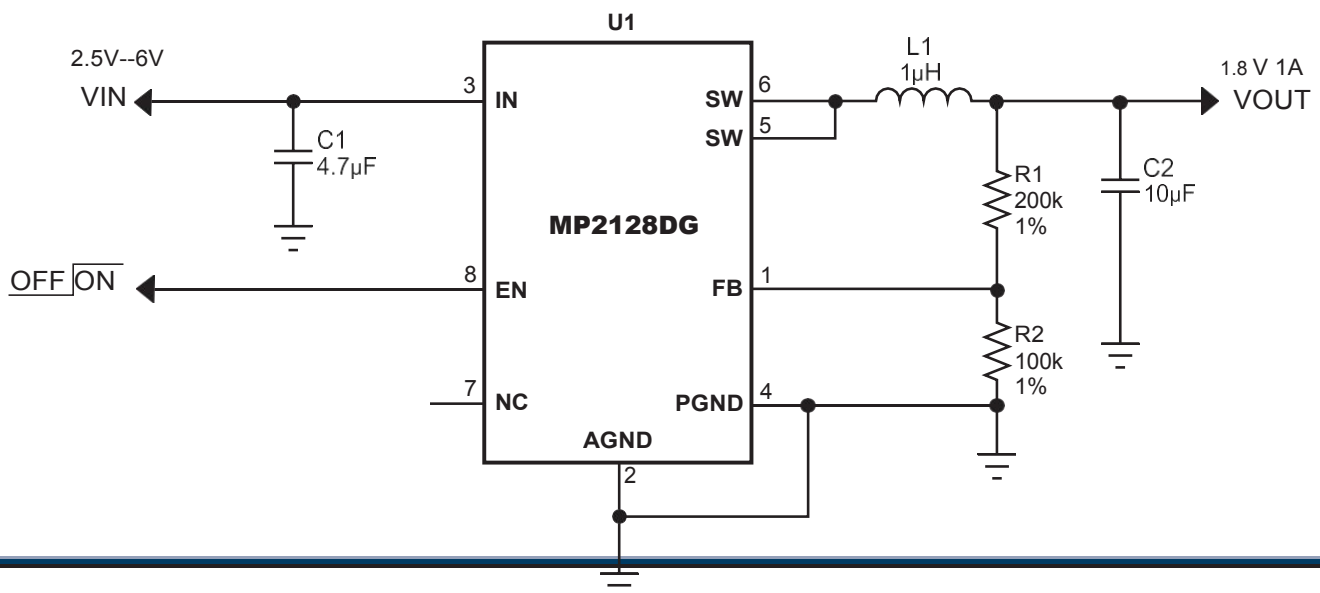

### ORDERING INFORMATION

Part Number*	Package	Top Marking	Temperature
MP2128DT	SOT23	2H	-40°C to +85°C
Part Number**	Package	Top Marking	Temperature
MP2128DG	QFN8(2mmx2mm)	2H	-40°C to +85°C

\* For Tape & Reel, add suffix -Z (eg. MP2128DT-Z). For RoHS Compliant Packaging, add suffix -LF (eg. MP2128DT-LF-Z)

\*\* For Tape & Reel, add suffix -Z (eg. MP2128DG-Z). For RoHS Compliant Packaging, add suffix -LF (eg. MP2128DG-LF-Z)

### PACKAGE REFERENCE

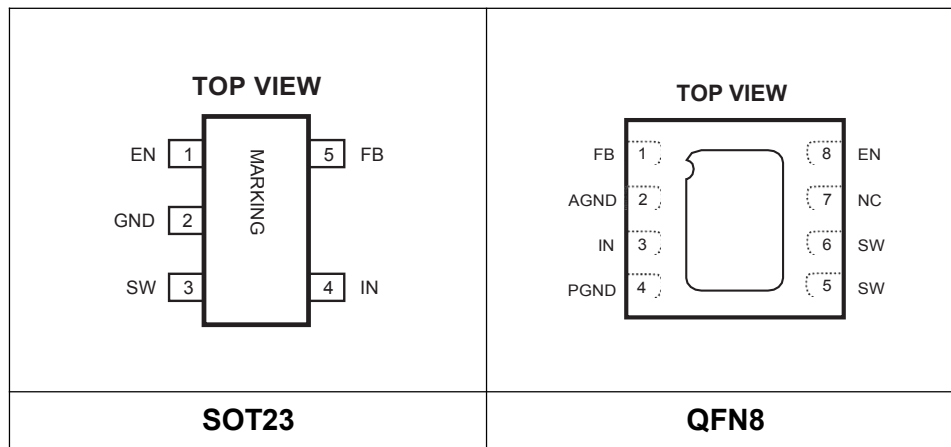

### ABSOLUTE MAXIMUM RATINGS (1)

IN to GND.....	V to +6.5V
SW to GND.....	V to $V_{IN} + 0.3V$
FB, EN to GND.....	V to +6.5V
Continuous Power Dissipation. ( $T_A = +25^\circ C$ ) (2)	
SOT23.....	0.57W
QFN8 (2mmx2mm).....	2.5W
Junction Temperature.....	150°C
Lead Temperature.....	260°C
Storage Temperature.....	65°C to +150°C

### Recommended Operating Conditions (3)

Supply Voltage $V_{IN}$ .....	V to 6V
Output Voltage $V_{OUT}$ .....	V to 6V
Operating Temperature.....	40°C to +85°C

Thermal Resistance (4)	$\theta_{JA}$	$\theta_{JC}$
SOT23 .....	220.....	110.. °C/W
QFN8 (2mmx2mm).....	50.....	12.... °C/W

#### Notes:

- 1) Exceeding these ratings may damage the device.
- 2) The maximum allowable power dissipation is a function of the maximum junction temperature  $T_J$  (MAX), the junction-to-ambient thermal resistance  $\theta_{JA}$ , and the ambient temperature  $T_A$ . The maximum allowable continuous power dissipation at any ambient temperature is calculated by  $P_D$  (MAX) =  $(T_J$  (MAX)- $T_A$ )/ $\theta_{JA}$ . Exceeding the maximum allowable power dissipation will cause excessive die temperature, and the regulator will go into thermal shutdown. Internal thermal shutdown circuitry protects the device from permanent damage.
- 3) The device is not guaranteed to function outside of its operating conditions.
- 4) Measured on JESD51-7, 4-layer PCB.

**ELECTRICAL CHARACTERISTICS (5)**
 $V_{IN} = V_{EN} = 3.6V$ ,  $T_A = +25^{\circ}C$ , unless otherwise noted.

Parameters	Condition	Min	Typ	Max	Units
Supply Current	$V_{EN} = V_{IN}$ , $V_{FB} = 0.65V$		350		$\mu A$
Shutdown Current	$V_{EN} = 0V$ , $V_{IN} = 6V$		0.01	1	$\mu A$
IN Under Voltage Lockout Threshold	Rising Edge	1.8	2.1	2.3	V
IN Under Voltage Lockout Hysteresis			250		mV
Regulated FB Voltage	$T_A = +25^{\circ}C$	0.582	0.594	0.606	V
	$-40^{\circ}C \leq T_A \leq +85^{\circ}C$	0.576	0.594	0.612	V
FB Input Bias Current	$V_{FB} = 0.65V$	-50		50	nA
PFET Current Limit	Duty=100%		1.5		A
PFET On-Resistance	$I_{SW} = 100mA$		200		m $\Omega$
NFET On-Resistance	$I_{SW} = -100mA$		150		m $\Omega$
SW Leakage Current	$V_{EN} = 0V$ ; $V_{IN} = 6V$ $V_{SW} = 0V$ or $6V$	-1		1	$\mu A$
EN High Threshold	$-40^{\circ}C \leq T_A \leq +85^{\circ}C$	1.6			V
EN Low Threshold	$-40^{\circ}C \leq T_A \leq +85^{\circ}C$			0.4	V
Internal Soft-Start Time			100		$\mu s$
Oscillator Frequency		2.4	2.8	3.2	MHz
Thermal Shutdown Threshold	Hysteresis=20 $^{\circ}C$		150		$^{\circ}C$

**Note:**

 5) Production test at +25 $^{\circ}C$ . Specifications over the temperature range are guaranteed by design and characterization.

## TYPICAL PERFORMANCE CHARACTERISTICS

$V_{IN}=6V$ ,  $V_{OUT}=1.8V$ ,  $L=1.2\mu H$ ,  $C2=10\mu F$ ,  $T_A=25^\circ C$ , unless otherwise noted.

**Efficiency vs. Load Current**

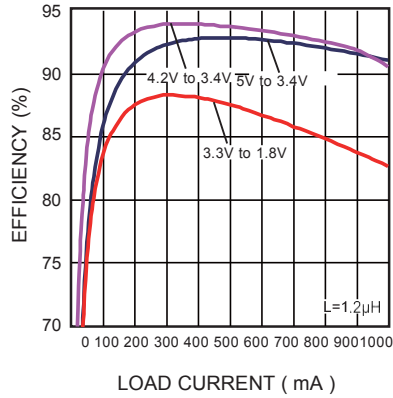

**Steady State Operation**

$I_{OUT}=0A$

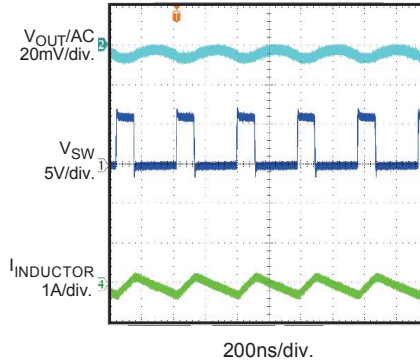

**Steady State Operation**

$I_{OUT}=1A$

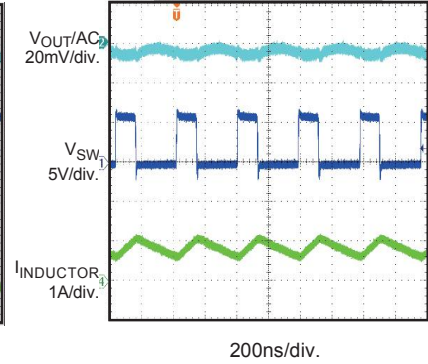

**Start-up Through Enable**

$I_{OUT}=0A$

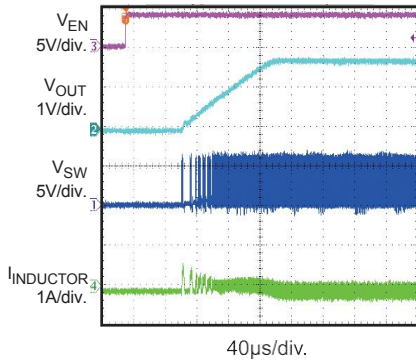

**Start-up Through Enable**

$I_{OUT}=1A$

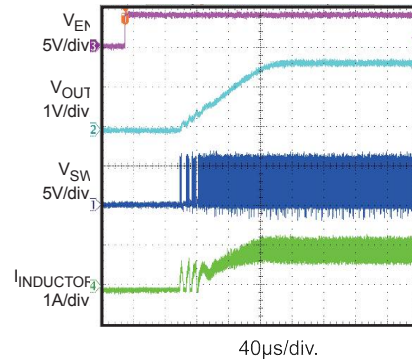

**Power-down Through Enable**

$I_{OUT}=0A$

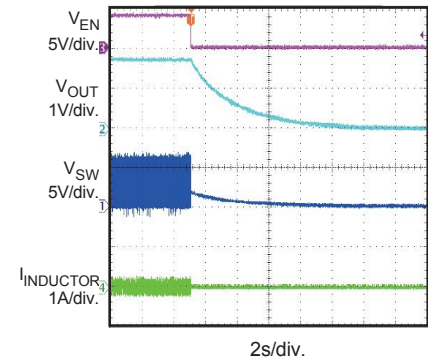

**Power-down Through Enable**

$I_{OUT}=1A$

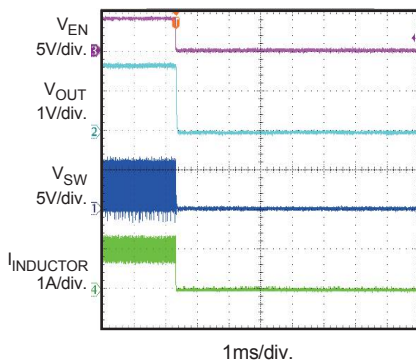

**Load Transient**

Load Step: 100mA-400mA,  
 $V_{IN}=4.2V$ ,  $V_{OUT}=3.4V$

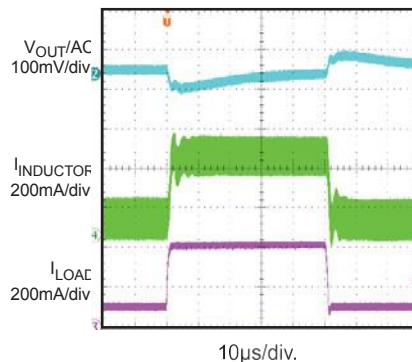

**Load Transient**

Load Step: 100mA-400mA,  
Slew Rate: 250mA/μs

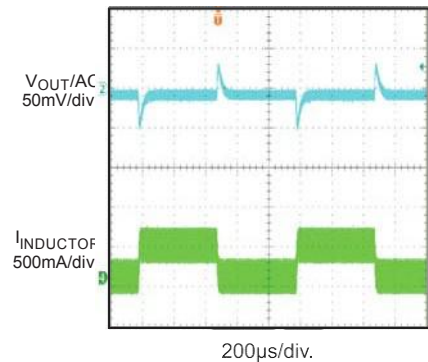

## PIN FUNCTIONS

SOT23 Pin #	QFN Pin #	Name	Description
1	8	EN	Regulator Enable Control Input. Drive EN above 1.6V to turn on the part. Drive EN below 0.4V to turn it off.
2	2,4	GND	Ground.
3	5,6	SW	Power Switch Output. Inductor connection to drains of the internal PFET and NFET switches.
4	3	IN	Supply Input. Bypass to GND with a 4.7 $\mu$ F or bigger value ceramic capacitor.
5	1	FB	Feedback Input. Connect FB to the center point of the external resistor divider. The regulated feedback voltage is 0.6V.

## FUNCTIONAL BLOCK DIAGRAM

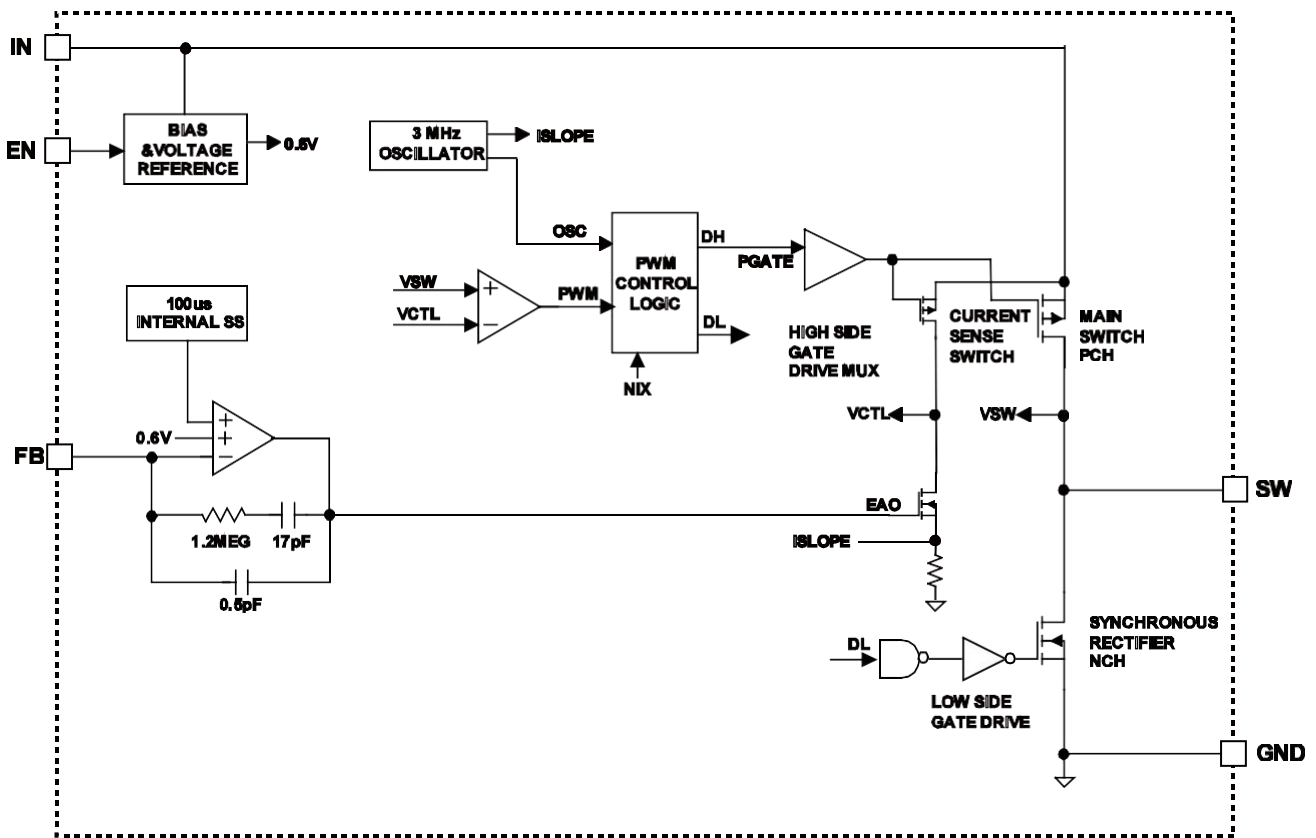

Figure 1— Functional Block Diagram

## FUNCTIONAL DESCRIPTION

MP2128 is a 3MHz constant frequency, current mode, PWM step-down converter. The device integrates both a main switch and a synchronous rectifier, which provides high efficiency and eliminates an external Schottky diode. It is ideal for powering portable equipment that runs from a single Li-Ion or Li-Polymer battery.

The MP2128 can achieve 100% duty cycle. The duty cycle D of a step-down converter is defined as:

$$D = T_{ON} \times f_{OSC} \times 100\% \approx \frac{V_{OUT}}{V_{IN}} \times 100\%$$

Where,

T<sub>on</sub>: Main Switch ON time  
 F<sub>osc</sub>: Switching frequency (3MHz)  
 V<sub>out</sub>: Output voltage  
 V<sub>in</sub>: Input voltage

### Peak Current Mode PWM Control

Slope compensated current mode PWM control provides stable switching and cycle-by-cycle current limit for superior load and line response and protection of the internal main switch and synchronous rectifier. The MP2128 switches at a constant frequency (3MHz) and regulates the output voltage. During each cycle the PWM comparator modulates the power transferred to the load by changing the inductor peak current based on the feedback error voltage.

During normal operation, the main switch is turned on for a certain time to ramp the inductor current at each rising edge of the internal oscillator, and switched off when the peak inductor current is above the error voltage.

When the main switch is off, the synchronous rectifier will be turned on immediately and stay on until the next cycle starts.

### Dropout Operation

The MP2128 allows the main switch to remain on for more than one switching cycle and increases the duty cycle while the input voltage is dropping close to the output voltage. When the duty cycle reaches 100%, the main switch is held on continuously to deliver current to the output up to the PFET current limit. The output voltage then is the input voltage minus the voltage drop across the main switch and the inductor.

### Short Circuit Protection

The MP2128 has short circuit protection. When the output is shorted to ground, the oscillator frequency is reduced to prevent the inductor current from increasing beyond the PFET current limit. The PFET current limit is also reduced to lower the short-circuit current. The frequency and current limit will return to the normal values once the short circuit condition is removed and the feedback voltage reaches 0.6V.

### Maximum Load current

The MP2128 can operate down to 2.5V input voltage, however the maximum load current decreases at lower input due to large IR drop on the main switch and synchronous rectifier. The slope compensation signal reduces the peak inductor current as a function of the duty cycle to prevent sub-harmonic oscillations at duty cycles greater than 50%. Conversely the current limit increases as the duty cycle decreases.

## PACKAGE INFORMATION

### SOT23

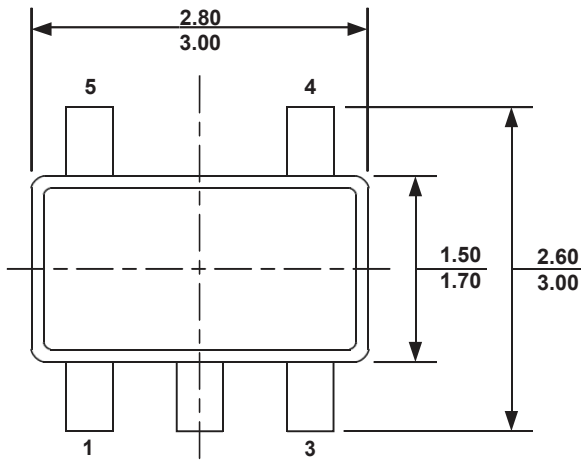

**TOP VIEW**

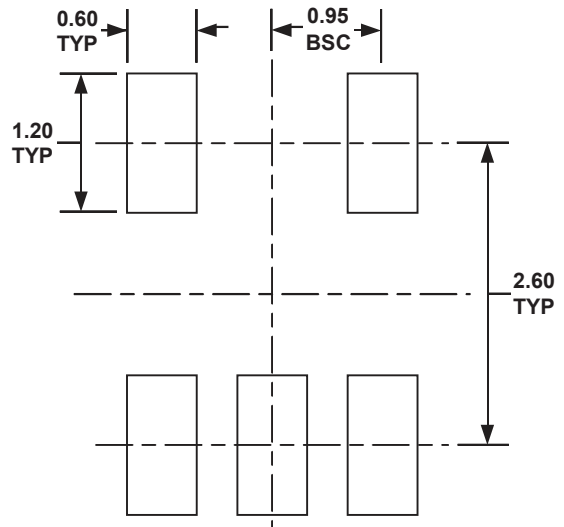

**RECOMMENDED LAND PATTERN**

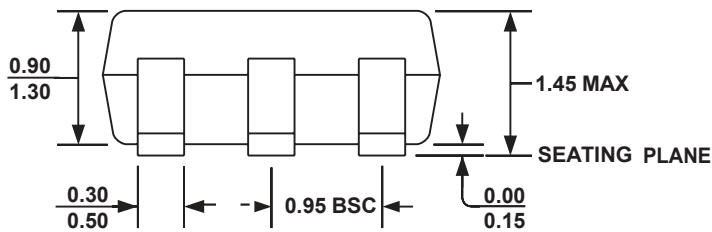

**FRONT VIEW**

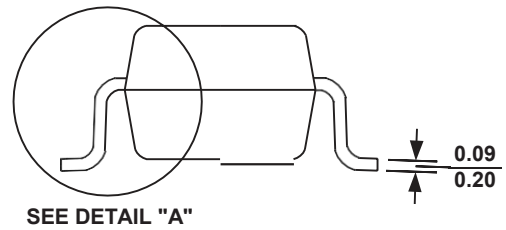

**SIDE VIEW**

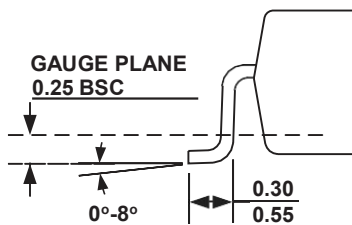

**DETAIL A**

#### NOTE:

- 1) ALL DIMENSIONS ARE IN MILLIMETERS.
- 2) PACKAGE LENGTH DOES NOT INCLUDE MOLD FLASH, PROTRUSION OR GATE BURR.
- 3) PACKAGE WIDTH DOES NOT INCLUDE INTERLEAD FLASH OR PROTRUSION.
- 4) LEAD COPLANARITY (BOTTOM OF LEADS AFTER FORMING) SHALL BE 0.10 MILLIMETERS MAX.
- 5) DRAWING CONFORMS TO JEDEC MO-178, VARIATION AA.
- 6) DRAWING IS NOT TO SCALE.

QFN8 (2mmX2mm)

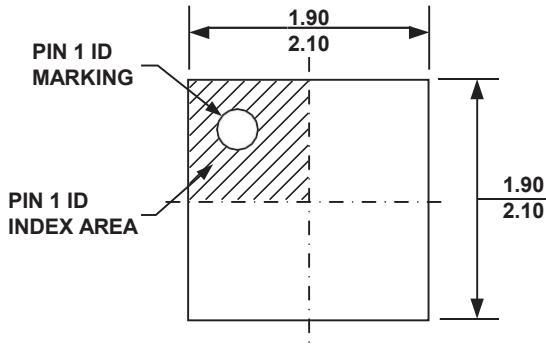

**TOP VIEW**

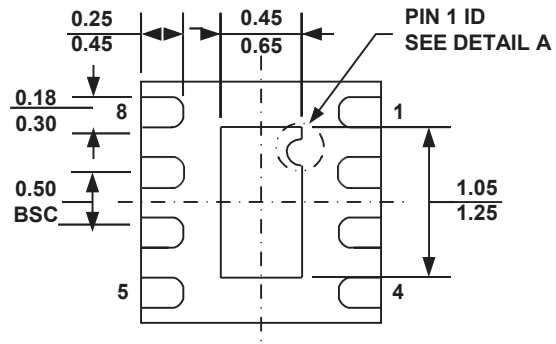

**BOTTOM VIEW**

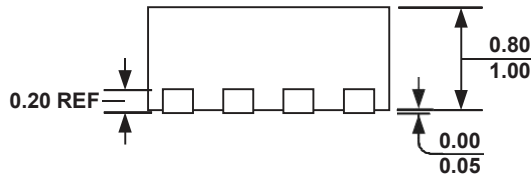

**SIDE VIEW**

**PIN 1 ID OPTION A  
R0.20 TYP.**

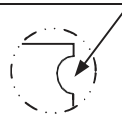

**PIN 1 ID OPTION B  
R0.20 TYP.**

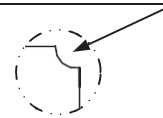

**DETAIL A**

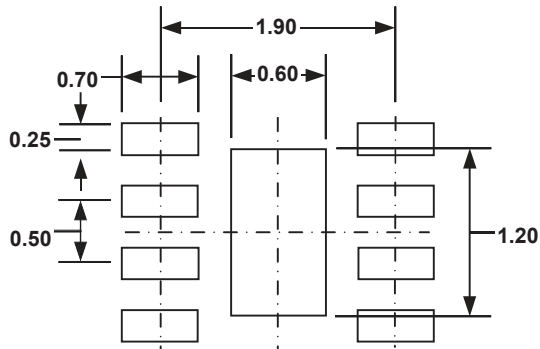

**RECOMMENDED LAND PATTERN**

**NOTE:**

- 1) ALL DIMENSIONS ARE IN MILLIMETERS.
- 2) EXPOSED PADDLE SIZE DOES NOT INCLUDE MOLD FLASH.
- 3) LEAD COPLANARITY SHALL BE 0.10 MILLIMETER MAX.
- 4) DRAWING CONFORMS TO JEDEC MO-229, VARIATION VCCD-3.
- 5) DRAWING IS NOT TO SCALE.

**NOTICE:** The information in this document is subject to change without notice. Users should warrant and guarantee that third party Intellectual Property rights are not infringed upon when integrating MPS products into any application. MPS will not assume any legal responsibility for any said applications.