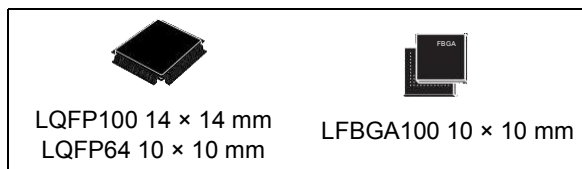


Connectivity line, ARM<sup>®</sup>-based 32-bit MCU with 64/256 KB Flash, USB OTG, Ethernet, 10 timers, 2 CANs, 2 ADCs, 14 communication interfaces

Datasheet - production data

## Features

- Core: ARM<sup>®</sup> 32-bit Cortex<sup>®</sup>-M3 CPU
  - 72 MHz maximum frequency, 1.25 DMIPS/MHz (Dhrystone 2.1) performance at 0 wait state memory access
  - Single-cycle multiplication and hardware division
- Memories
  - 64 to 256 Kbytes of Flash memory
  - 64 Kbytes of general-purpose SRAM
- Clock, reset and supply management
  - 2.0 to 3.6 V application supply and I/Os
  - POR, PDR, and programmable voltage detector (PVD)
  - 3-to-25 MHz crystal oscillator
  - Internal 8 MHz factory-trimmed RC
  - Internal 40 kHz RC with calibration
  - 32 kHz oscillator for RTC with calibration
- Low power
  - Sleep, Stop and Standby modes
  - VBAT supply for RTC and backup registers
- 2 × 12-bit, 1 μs A/D converters (16 channels)
  - Conversion range: 0 to 3.6 V
  - Sample and hold capability
  - Temperature sensor
  - up to 2 MSPS in interleaved mode
- 2 × 12-bit D/A converters
- DMA: 12-channel DMA controller
  - Supported peripherals: timers, ADCs, DAC, I2Ss, SPIs, I2Cs and USARTs
- Debug mode
  - Serial wire debug (SWD) & JTAG interfaces
  - Cortex<sup>®</sup>-M3 Embedded Trace Macrocell™
- Up to 80 fast I/O ports
  - 51/80 I/Os, all mappable on 16 external interrupt vectors and almost all 5V-tolerant
- CRC calculation unit, 96-bit unique ID



- Up to 10 timers with pinout remap capability
  - Up to four 16-bit timers, each with up to 4 IC/OC/PWM or pulse counter and quadrature (incremental) encoder input
  - 1 × 16-bit motor control PWM timer with dead-time generation and emergency stop
  - 2 × watchdog timers (Independent and Window)
  - SysTick timer: a 24-bit downcounter
  - 2 × 16-bit basic timers to drive the DAC
- Up to 14 communication interfaces with pinout remap capability
  - Up to 2 × I2C interfaces (SMBus/PMBus)
  - Up to 5 USARTs (ISO 7816 interface, LIN, IrDA capability, modem control)
  - Up to 3 SPIs (18 Mbit/s), 2 with a multiplexed I2S interface that offers audio class accuracy via advanced PLL schemes
  - 2 × CAN interfaces (2.0B Active) with 512 bytes of dedicated SRAM
  - USB 2.0 full-speed device/host/OTG controller with on-chip PHY that supports HNP/SRP/ID with 1.25 Kbytes of dedicated SRAM
  - 10/100 Ethernet MAC with dedicated DMA and SRAM (4 Kbytes): IEEE1588 hardware support, MII/RMII available on all packages

Table 1. Device summary

Reference	Part number
STM32F105xx	STM32F105R8, STM32F105V8 STM32F105RB, STM32F105VB STM32F105RC, STM32F105VC
STM32F107xx	STM32F107RB, STM32F107VB STM32F107RC, STM32F107VC

# Contents

- 1 Introduction.....9**
- 2 Description..... 10**
  - 2.1 Device overview..... 10
  - 2.2 Full compatibility throughout the family..... 12
  - 2.3 Overview..... 13
    - 2.3.1 ARM Cortex-M3 core with embedded Flash and SRAM..... 14
    - 2.3.2 Embedded Flash memory..... 14
    - 2.3.3 CRC (cyclic redundancy check) calculation unit..... 14
    - 2.3.4 Embedded SRAM..... 14
    - 2.3.5 Nested vectored interrupt controller (NVIC)..... 14
    - 2.3.6 External interrupt/event controller (EXTI)..... 15
    - 2.3.7 Clocks and startup..... 15
    - 2.3.8 Boot modes..... 15
    - 2.3.9 Power supply schemes..... 16
    - 2.3.10 Power supply supervisor..... 16
    - 2.3.11 Voltage regulator..... 16
    - 2.3.12 Low-power modes..... 16
    - 2.3.13 DMA..... 17
    - 2.3.14 RTC (real-time clock) and backup registers..... 17
    - 2.3.15 Timers and watchdogs..... 18
    - 2.3.16 I<sup>2</sup>C bus..... 19
    - 2.3.17 Universal synchronous/asynchronous receiver transmitters (USARTs) . 19
    - 2.3.18 Serial peripheral interface (SPI)..... 20
    - 2.3.19 Inter-integrated sound (I<sup>2</sup>S)..... 20
    - 2.3.20 Ethernet MAC interface with dedicated DMA and IEEE 1588 support . 20
    - 2.3.21 Controller area network (CAN)..... 21
    - 2.3.22 Universal serial bus on-the-go full-speed (USBOTG FS)..... 21
    - 2.3.23 GPIOs (general-purpose inputs/outputs)..... 21
    - 2.3.24 Remap capability..... 22
    - 2.3.25 ADCs (analog-to-digital converters)..... 22
    - 2.3.26 DAC (digital-to-analog converter)..... 22
    - 2.3.27 Temperature sensor..... 23
    - 2.3.28 Serial wire JTAG debug port (SWJ-DP)..... 23

2.3.29 Embedded Trace Macrocell™ ..... 23

**3 Pinouts and pin description..... 24**

**4 Memory mapping..... 33**

**5 Electrical characteristics..... 34**

5.1 Parameter conditions..... 34

5.1.1 Minimum and maximum values..... 34

5.1.2 Typical values..... 34

5.1.3 Typical curves..... 34

5.1.4 Loading capacitor..... 34

5.1.5 Pin input voltage..... 34

5.1.6 Power supply scheme..... 35

5.1.7 Current consumption measurement..... 35

5.2 Absolute maximum ratings..... 36

5.3 Operating conditions..... 37

5.3.1 General operating conditions..... 37

5.3.2 Operating conditions at power-up / power-down..... 38

5.3.3 Embedded reset and power control block characteristics..... 38

5.3.4 Embedded reference voltage..... 39

5.3.5 Supply current characteristics..... 39

5.3.6 External clock source characteristics..... 47

5.3.7 Internal clock source characteristics..... 52

5.3.8 PLL, PLL2 and PLL3 characteristics..... 53

5.3.9 Memory characteristics..... 54

5.3.10 EMC characteristics..... 54

5.3.11 Absolute maximum ratings (electrical sensitivity)..... 56

5.3.12 I/O current injection characteristics..... 56

5.3.13 I/O port characteristics..... 57

5.3.14 NRST pin characteristics..... 62

5.3.15 TIM timer characteristics..... 63

5.3.16 Communications interfaces..... 64

5.3.17 12-bit ADC characteristics..... 74

5.3.18 DAC electrical specifications..... 79

5.3.19 Temperature sensor characteristics..... 81

DocID15274 Rev 10

3/108

**6 Package information..... 82**



6.1 LFBGA100 package information..... 82

6.2 LQFP100 package information..... 85

6.3 LQFP64 package information..... 88

2/108

DocID15274 Rev 10

2/108

DocID15274 Rev 10





---

6.4	Thermal characteristics.....	91
6.4.1	Reference document.....	91
6.4.2	Selecting the product temperature range.....	92
<b>7</b>	<b>Part numbering.....</b>	<b>94</b>
<b>Appendix A</b>	<b>Application block diagrams.....</b>	<b>95</b>
A.1	USB OTG FS interface solutions.....	95
A.2	Ethernet interface solutions.....	97
A.3	Complete audio player solutions.....	99
A.4	USB OTG FS interface + Ethernet/I <sup>2</sup> S interface solutions.....	100
<b>8</b>	<b>Revision history.....</b>	<b>103</b>



## List of tables

Table 1.	Device summary.....	1
Table 2.	STM32F105xx and STM32F107xx features and peripheral counts.....	10
Table 3.	STM32F105xx and STM32F107xx family versus STM32F103xx family.....	12
Table 4.	Timer feature comparison.....	18
Table 5.	Pin definitions.....	27
Table 6.	Voltage characteristics.....	36
Table 7.	Current characteristics.....	36
Table 8.	Thermal characteristics.....	37
Table 9.	General operating conditions.....	37
Table 10.	Operating condition at power-up / power down.....	38
Table 11.	Embedded reset and power control block characteristics.....	38
Table 12.	Embedded internal reference voltage.....	39
Table 13.	Maximum current consumption in Run mode, code with data processing running from Flash.....	40
Table 14.	Maximum current consumption in Run mode, code with data processing running from RAM.....	40
Table 15.	Maximum current consumption in Sleep mode, code running from Flash or RAM.....	41
Table 16.	Typical and maximum current consumptions in Stop and Standby modes.....	41
Table 17.	Typical current consumption in Run mode, code with data processing running from Flash.....	44
Table 18.	Typical current consumption in Sleep mode, code running from Flash or RAM.....	45
Table 19.	Peripheral current consumption.....	46
Table 20.	High-speed external user clock characteristics.....	47
Table 21.	Low-speed external user clock characteristics.....	48
Table 22.	HSE 3-25 MHz oscillator characteristics.....	49
Table 23.	LSE oscillator characteristics ( $f_{LSE} = 32.768$ kHz).....	50
Table 24.	HSI oscillator characteristics.....	52
Table 25.	LSI oscillator characteristics.....	52
Table 26.	Low-power mode wakeup timings.....	53
Table 27.	PLL characteristics.....	53
Table 28.	PLL2 and PLL3 characteristics.....	53
Table 29.	Flash memory characteristics.....	54
Table 30.	Flash memory endurance and data retention.....	54
Table 31.	EMS characteristics.....	55
Table 32.	EMI characteristics.....	56
Table 33.	ESD absolute maximum ratings.....	56
Table 34.	Electrical sensitivities.....	56
Table 35.	I/O current injection susceptibility.....	57
Table 36.	I/O static characteristics.....	57
Table 37.	Output voltage characteristics.....	60
Table 38.	I/O AC characteristics.....	61
Table 39.	NRST pin characteristics.....	62
Table 40.	TIMx characteristics.....	63
Table 41.	I <sup>2</sup> C characteristics.....	64
Table 42.	SCL frequency ( $f_{PCLK1} = 36$ MHz, $V_{DD} = 3.3$ V).....	65
Table 43.	SPI characteristics.....	66
Table 44.	I <sup>2</sup> S characteristics.....	69



Table 45.	USB OTG FS startup time.....	71
Table 46.	USB OTG FS DC electrical characteristics.....	71
Table 47.	USB OTG FS electrical characteristics.....	72
Table 48.	Ethernet DC electrical characteristics.....	72
Table 49.	Dynamic characteristics: Ethernet MAC signals for SMI.....	72
Table 50.	Dynamic characteristics: Ethernet MAC signals for RMII.....	73
Table 51.	Dynamic characteristics: Ethernet MAC signals for MII.....	74
Table 52.	ADC characteristics.....	74
Table 53.	$R_{AIN}$ max for $f_{ADC} = 14$ MHz.....	75
Table 54.	ADC accuracy - limited test conditions.....	76
Table 55.	ADC accuracy.....	76
Table 56.	DAC characteristics.....	79
Table 57.	TS characteristics.....	81
Table 58.	LFBGA100 recommended PCB design rules (0.8 mm pitch BGA).....	83
Table 59.	LQPF100 - 100-pin, 14 x 14 mm low-profile quad flat package mechanical data.....	85
Table 60.	LQFP64 – 10 x 10 mm 64 pin low-profile quad flat package mechanical data.....	88
Table 61.	Package thermal characteristics.....	91
Table 62.	Ordering information scheme.....	94
Table 63.	PLL configurations.....	101
Table 64.	Applicative current consumption in Run mode, code with data processing running from Flash.....	102
Table 65.	Document revision history.....	103





# List of figures

Figure 1.	STM32F105xx and STM32F107xx connectivity line block diagram.....	13
Figure 2.	STM32F105xx and STM32F107xx connectivity line BGA100 ballout top view.....	24
Figure 3.	STM32F105xx and STM32F107xx connectivity line LQFP100 pinout.....	25
Figure 4.	STM32F105xx and STM32F107xx connectivity line LQFP64 pinout.....	26
Figure 5.	Memory map.....	33
Figure 6.	Pin loading conditions.....	34
Figure 7.	Pin input voltage.....	34
Figure 8.	Power supply scheme.....	35
Figure 9.	Current consumption measurement scheme.....	35
Figure 10.	Typical current consumption on V <sub>BAT</sub> with RTC on vs. temperature at different V <sub>BAT</sub> values.....	42
Figure 11.	Typical current consumption in Stop mode with regulator in Run mode versus temperature at different V <sub>DD</sub> values.....	42
Figure 12.	Typical current consumption in Stop mode with regulator in Low-power mode versus temperature at different V <sub>DD</sub> values.....	43
Figure 13.	Typical current consumption in Standby mode versus temperature at different V <sub>DD</sub> values.....	43
Figure 14.	High-speed external clock source AC timing diagram.....	48
Figure 15.	Low-speed external clock source AC timing diagram.....	49
Figure 16.	Typical application with an 8 MHz crystal.....	50
Figure 17.	Typical application with a 32.768 kHz crystal.....	51
Figure 18.	Standard I/O input characteristics - CMOS port.....	58
Figure 19.	Standard I/O input characteristics - TTL port.....	59
Figure 20.	5 V tolerant I/O input characteristics - CMOS port.....	59
Figure 21.	5 V tolerant I/O input characteristics - TTL port.....	59
Figure 22.	I/O AC characteristics definition.....	62
Figure 23.	Recommended NRST pin protection.....	63
Figure 24.	I <sup>2</sup> C bus AC waveforms and measurement circuit.....	65
Figure 25.	SPI timing diagram - slave mode and CPHA = 0.....	67
Figure 26.	SPI timing diagram - slave mode and CPHA = 1 <sup>(1)</sup> .....	67
Figure 27.	SPI timing diagram - master mode <sup>(1)</sup> .....	68
Figure 28.	I <sup>2</sup> S slave timing diagram (Philips protocol) <sup>(1)</sup> .....	70
Figure 29.	I <sup>2</sup> S master timing diagram (Philips protocol) <sup>(1)</sup> .....	70
Figure 30.	USB OTG FS timings: definition of data signal rise and fall time.....	71
Figure 31.	Ethernet SMI timing diagram.....	72
Figure 32.	Ethernet RMII timing diagram.....	73
Figure 33.	Ethernet MII timing diagram.....	73
Figure 34.	ADC accuracy characteristics.....	77
Figure 35.	Typical connection diagram using the ADC.....	77
Figure 36.	Power supply and reference decoupling (V <sub>REF+</sub> not connected to V <sub>DDA</sub> ).....	78
Figure 37.	Power supply and reference decoupling (V <sub>REF+</sub> connected to V <sub>DDA</sub> ).....	78
Figure 38.	12-bit buffered /non-buffered DAC.....	80
Figure 39.	LFBGA100 - 10 x 10 mm low profile fine pitch ball grid array package outline.....	82
Figure 40.	LFBGA100 – 100-ball low profile fine pitch ball grid array, 10 x 10 mm, 0.8 mm pitch, package mechanical data.....	83
Figure 41.	LFBGA100 – 100-ball low profile fine pitch ball grid array, 10 x 10 mm, 0.8 mm pitch, package recommended footprint.....	83



Figure 42.	LFBGA100 marking example (package top view).....	84
Figure 43.	LQFP100 – 14 x 14 mm 100 pin low-profile quad flat package outline.....	85
Figure 44.	LQFP100 - 100-pin, 14 x 14 mm low-profile quad flat recommended footprint.....	86
Figure 45.	LQFP100 marking example (package top view).....	87
Figure 46.	LQFP64 – 10 x 10 mm 64 pin low-profile quad flat package outline.....	88
Figure 47.	LQFP64 - 64-pin, 10 x 10 mm low-profile quad flat recommended footprint.....	89
Figure 48.	LQFP64 marking example (package top view).....	90
Figure 49.	LQFP100 $P_D$ max vs. $T_A$ .....	93
Figure 50.	USB OTG FS device mode.....	95
Figure 51.	Host connection.....	95
Figure 52.	OTG connection (any protocol).....	96
Figure 53.	MII mode using a 25 MHz crystal.....	97
Figure 54.	RMII with a 50 MHz oscillator.....	97
Figure 55.	RMII with a 25 MHz crystal and PHY with PLL.....	98
Figure 56.	RMII with a 25 MHz crystal.....	98
Figure 57.	Complete audio player solution 1.....	99
Figure 58.	Complete audio player solution 2.....	99
Figure 59.	USB O44TG FS + Ethernet solution.....	100
Figure 60.	USB OTG FS + I <sup>2</sup> S (Audio) solution.....	100



# 1 Introduction

This datasheet provides the description of the STM32F105xx and STM32F107xx connectivity line microcontrollers. For more details on the whole STMicroelectronics STM32F10xxx family, refer to [Section 2.2: Full compatibility throughout the family](#).

The STM32F105xx and STM32F107xx datasheet should be read in conjunction with the STM32F10xxx reference manual.

For information on programming, erasing and protection of the internal Flash memory refer to the STM32F10xxx Flash programming manual.

The reference and Flash programming manuals are both available from the STMicroelectronics website [www.st.com](http://www.st.com).

For information on the Cortex<sup>®</sup>-M3 core refer to the Cortex<sup>®</sup>-M3 Technical Reference Manual, available from the [www.arm.com](http://www.arm.com) website.





## 2 Description

The STM32F105xx and STM32F107xx connectivity line family incorporates the high-performance ARM® Cortex®-M3 32-bit RISC core operating at a 72 MHz frequency, high-speed embedded memories (Flash memory up to 256 Kbytes and SRAM 64 Kbytes), and

an extensive range of enhanced I/Os and peripherals connected to two APB buses. All devices offer two 12-bit ADCs, four general-purpose 16-bit timers plus a PWM timer, as well as standard and advanced communication interfaces: up to two I<sup>2</sup>Cs, three SPIs, two I2Ss, five USARTs, an USB OTG FS and two CANs. Ethernet is available on the STM32F107xx only.

The STM32F105xx and STM32F107xx connectivity line family operates in the –40 to +105 °C temperature range, from a 2.0 to 3.6 V power supply. A comprehensive set of power-saving mode allows the design of low-power applications.

The STM32F105xx and STM32F107xx connectivity line family offers devices in three different package types: from 64 pins to 100 pins. Depending on the device chosen, different sets of peripherals are included, the description below gives an overview of the complete range of peripherals proposed in this family.

These features make the STM32F105xx and STM32F107xx connectivity line microcontroller family suitable for a wide range of applications such as motor drives and application control, medical and handheld equipment, industrial applications, PLCs, inverters, printers, and scanners, alarm systems, video intercom, HVAC and home audio equipment.

### 2.1 Device overview

*Figure 1* shows the general block diagram of the device family.

**Table 2. STM32F105xx and STM32F107xx features and peripheral counts**

Peripherals <sup>(1)</sup>		STM32F105Rx			STM32F107Rx		STM32F105Vx			STM32F107Vx	
Flash memory in Kbytes		64	128	256	128	256	64	128	256	128	256
SRAM in Kbytes		64									
Package		LQFP64				LQFP 100	LQFP 100, BGA 100	LQFP 100	LQFP 100	LQFP 100, BGA 100	
Ethernet		No			Yes		No			Yes	
Timers	General-purpose	4									
	Advanced-control	1									
	Basic	2									





Table 2. STM32F105xx and STM32F107xx features and peripheral counts (continued)

Peripherals <sup>(1)</sup>		STM32F105Rx	STM32F107Rx	STM32F105Vx	STM32F107Vx
Communication interfaces	SPI(I <sup>2</sup> S) <sup>(2)</sup>	3(2)	3(2)	3(2)	3(2)
	I <sup>2</sup> C	2	1	2	1
	USART	5			
	USB OTG FS	Yes			
	CAN	2			
GPIOs		51		80	
12-bit ADC		2			
Number of channels		16			
12-bit DAC		2			
Number of channels		2			
CPU frequency		72 MHz			
Operating voltage		2.0 to 3.6 V			
Operating temperatures		Ambient temperatures: –40 to +85 °C / –40 to +105 °C Junction temperature: –40 to + 125 °C			

1. Refer to [Table 5: Pin definitions](#) for peripheral availability when the I/O pins are shared by the peripherals required by the application.
2. The SPI2 and SPI3 interfaces give the flexibility to work in either the SPI mode or the I<sup>2</sup>S audio mode.



## 2.2 Full compatibility throughout the family

The STM32F105xx and STM32F107xx constitute the connectivity line family whose members are fully pin-to-pin, software and feature compatible.

The STM32F105xx and STM32F107xx are a drop-in replacement for the low-density (STM32F103x4/6), medium-density (STM32F103x8/B) and high-density (STM32F103xC/D/E) performance line devices, allowing the user to try different memory densities and peripherals providing a greater degree of freedom during the development cycle.

**Table 3. STM32F105xx and STM32F107xx family versus STM32F103xx family<sup>(1)</sup>**

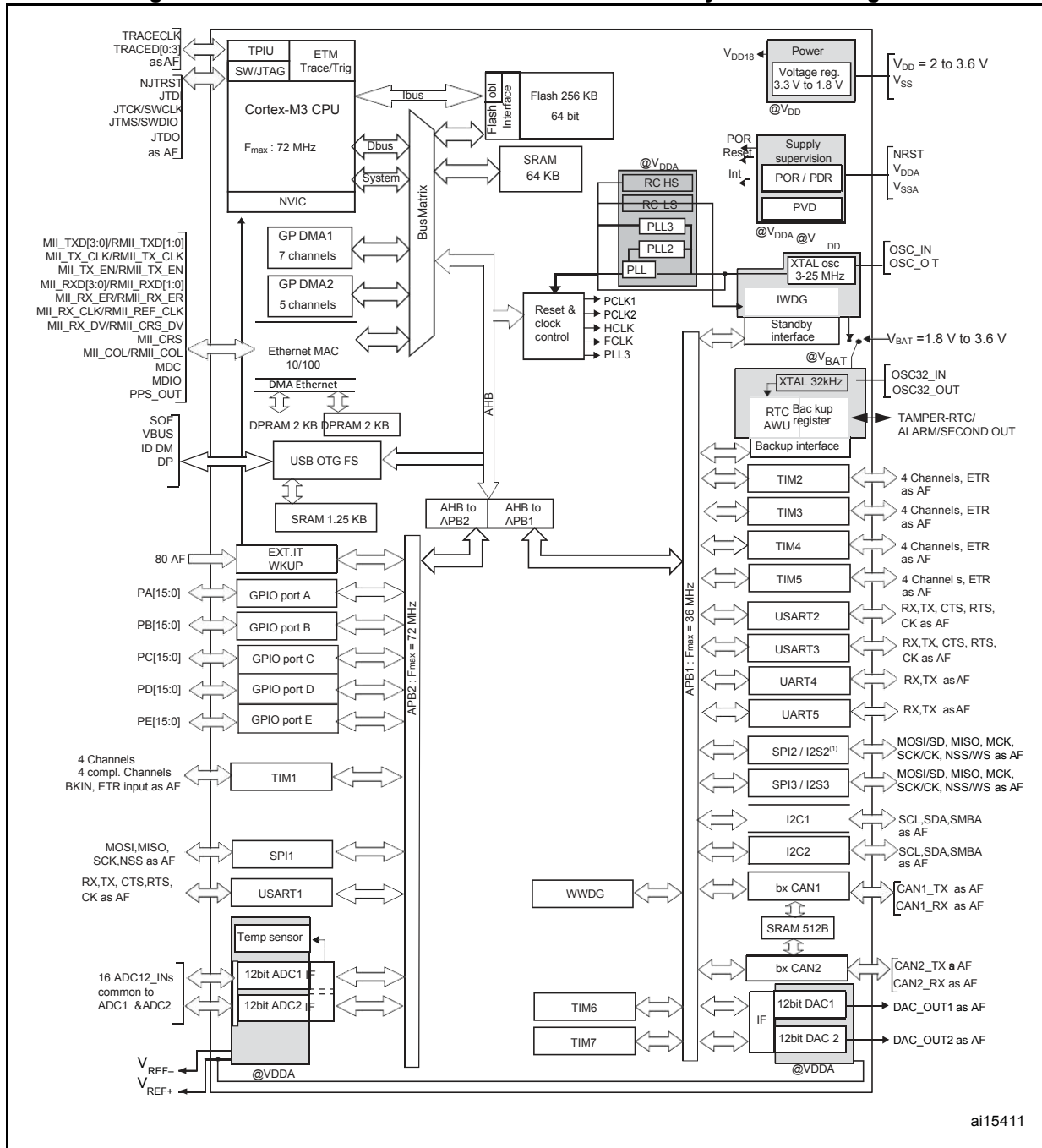
STM32 device	Low-density STM32F103xx devices		Medium-density STM32F103xx devices			High-density STM32F103xx devices			STM32F105xx			STM32F107xx				
	16	32	32	64	128	256	384	512	64	128	256	128	256			
Flash size (KB)	16	32	32	64	128	256	384	512	64	128	256	128	256			
RAM size (KB)	6	10	10	20	20	48	64	64	64	64	64	64	64			
144 pins																
100 pins																
64 pins	2 × USARTs 2 × 16-bit timers 1 × SPI, 1 × I <sup>2</sup> C, USB, CAN, 1 × PWM timer 2 × ADCs		2 × USARTs 2 × 16-bit timers 1 × SPI, 1 × I <sup>2</sup> C, USB, CAN, 1 × PWM timer 2 × ADCs			3 × USARTs 3 × 16-bit timers 2 × SPIs, 2 × I <sup>2</sup> Cs, USB, CAN, 1 × PWM timer 2 × ADCs			5 × USARTs 4 × 16-bit timers, 2 × basic timers, 3 × SPIs, 2 × I <sup>2</sup> Ss, 2 × I <sup>2</sup> Cs, USB, CAN, 2 × PWM timers 3 × ADCs, 2 × DACs, 1 × SDIO, FSMC (100- and 144-pin packages <sup>(2)</sup> )			5 × USARTs, 4 × 16-bit timers, 2 × basic timers, 3 × SPIs, 2 × I <sup>2</sup> Ss, 2 × I <sup>2</sup> Cs, USB OTG FS, 2 × CANs, 1 × PWM timer, 2 × ADCs, 2 × DACs			5 × USARTs, 4 × 16-bit timers, 2 × basic timers, 3 × SPIs, 2 × I <sup>2</sup> S, 1 × I <sup>2</sup> C, USB OTG FS, 2 × CANs, 1 × PWM timer, 2 × ADCs, 2 × DACs, Ethernet	
48 pins																
36 pins																

1. Refer to [Table 5: Pin definitions](#) for peripheral availability when the I/O pins are shared by the peripherals required by the application.
2. Ports F and G are not available in devices delivered in 100-pin packages.



### 2.3 Overview

Figure 1. STM32F105xx and STM32F107xx connectivity line block diagram



1.  $T_A = -40\text{ }^\circ\text{C}$  to  $+85\text{ }^\circ\text{C}$  (suffix 6, see [Table 62](#)) or  $-40\text{ }^\circ\text{C}$  to  $+105\text{ }^\circ\text{C}$  (suffix 7, see [Table 62](#)), junction temperature up to  $105\text{ }^\circ\text{C}$  or  $125\text{ }^\circ\text{C}$ , respectively.
2. AF = alternate function on I/O port pin.



### 2.3.1 ARM Cortex-M3 core with embedded Flash and SRAM

The ARM Cortex-M3 processor is the latest generation of ARM processors for embedded systems. It has been developed to provide a low-cost platform that meets the needs of MCU implementation, with a reduced pin count and low-power consumption, while delivering outstanding computational performance and an advanced system response to interrupts.

The ARM Cortex-M3 32-bit RISC processor features exceptional code-efficiency, delivering the high-performance expected from an ARM core in the memory size usually associated with 8- and 16-bit devices.

With its embedded ARM core, STM32F105xx and STM32F107xx connectivity line family is compatible with all ARM tools and software.

[Figure 1](#) shows the general block diagram of the device family.

### 2.3.2 Embedded Flash memory

64 to 256 Kbytes of embedded Flash is available for storing programs and data.

### 2.3.3 CRC (cyclic redundancy check) calculation unit

The CRC (cyclic redundancy check) calculation unit is used to get a CRC code from a 32-bit data word and a fixed generator polynomial.

Among other applications, CRC-based techniques are used to verify data transmission or storage integrity. In the scope of the EN/IEC 60335-1 standard, they offer a means of verifying the Flash memory integrity. The CRC calculation unit helps compute a signature of the software during runtime, to be compared with a reference signature generated at link-time and stored at a given memory location.

### 2.3.4 Embedded SRAM

64 Kbytes of embedded SRAM accessed (read/write) at CPU clock speed with 0 wait states.

### 2.3.5 Nested vectored interrupt controller (NVIC)

The STM32F105xx and STM32F107xx connectivity line embeds a nested vectored interrupt controller able to handle up to 67 maskable interrupt channels (not including the 16 interrupt lines of Cortex-M3) and 16 priority levels.

- Closely coupled NVIC gives low latency interrupt processing
- Interrupt entry vector table address passed directly to the core
- Closely coupled NVIC core interface
- Allows early processing of interrupts
- Processing of *late arriving* higher priority interrupts
- Support for tail-chaining
- Processor state automatically saved
- Interrupt entry restored on interrupt exit with no instruction overhead

This hardware block provides flexible interrupt management features with minimal interrupt latency.





### 2.3.6 External interrupt/event controller (EXTI)

The external interrupt/event controller consists of 20 edge detector lines used to generate interrupt/event requests. Each line can be independently configured to select the trigger event (rising edge, falling edge, both) and can be masked independently. A pending register maintains the status of the interrupt requests. The EXTI can detect an external line with a pulse width shorter than the Internal APB2 clock period. Up to 80 GPIOs can be connected to the 16 external interrupt lines.

### 2.3.7 Clocks and startup

System clock selection is performed on startup, however, the internal RC 8 MHz oscillator is selected as default CPU clock on reset. An external 3-25 MHz clock can be selected, in which case it is monitored for failure. If failure is detected, the system automatically switches back to the internal RC oscillator. A software interrupt is generated if enabled. Similarly, full interrupt management of the PLL clock entry is available when necessary (for example with failure of an indirectly used external oscillator).

A single 25 MHz crystal can clock the entire system including the ethernet and USB OTG FS peripherals. Several prescalers and PLLs allow the configuration of the AHB frequency, the high speed APB (APB2) and the low speed APB (APB1) domains. The maximum frequency of the AHB and the high speed APB domains is 72 MHz. The maximum allowed frequency of the low speed APB domain is 36 MHz. Refer to [Figure 59: USB O44TG FS + Ethernet solution on page 100](#).

The advanced clock controller clocks the core and all peripherals using a single crystal or oscillator. In order to achieve audio class performance, an audio crystal can be used. In this case, the I<sup>2</sup>S master clock can generate all standard sampling frequencies from 8 kHz to 96 kHz with less than 0.5% accuracy error. Refer to [Figure 60: USB OTG FS + I2S \(Audio\) solution on page 100](#).

To configure the PLLs, refer to [Table 63 on page 101](#), which provides PLL configurations according to the application type.

### 2.3.8 Boot modes

At startup, boot pins are used to select one of three boot options:

- Boot from User Flash
- Boot from System Memory
- Boot from embedded SRAM

The boot loader is located in System Memory. It is used to reprogram the Flash memory by using USART1, USART2 (remapped), CAN2 (remapped) or USB OTG FS in device mode (DFU: device firmware upgrade). For remapped signals refer to [Table 5: Pin definitions](#).

The USART peripheral operates with the internal 8 MHz oscillator (HSI), however the CAN and USB OTG FS can only function if an external 8 MHz, 14.7456 MHz or 25 MHz clock (HSE) is present.

For full details about the boot loader, refer to AN2606.



### 2.3.9 Power supply schemes

- $V_{DD} = 2.0$  to  $3.6$  V: external power supply for I/Os and the internal regulator. Provided externally through  $V_{DD}$  pins.
- $V_{SSA}$ ,  $V_{DDA} = 2.0$  to  $3.6$  V: external analog power supplies for ADC, Reset blocks, RCs and PLL (minimum voltage to be applied to  $V_{DDA}$  is  $2.4$  V when the ADC is used).  $V_{DDA}$  and  $V_{SSA}$  must be connected to  $V_{DD}$  and  $V_{SS}$ , respectively.
- $V_{BAT} = 1.8$  to  $3.6$  V: power supply for RTC, external clock 32 kHz oscillator and backup registers (through power switch) when  $V_{DD}$  is not present.

### 2.3.10 Power supply supervisor

The device has an integrated power-on reset (POR)/power-down reset (PDR) circuitry. It is always active, and ensures proper operation starting from/down to  $2$  V. The device remains in reset mode when  $V_{DD}$  is below a specified threshold,  $V_{POR/PDR}$ , without the need for an external reset circuit.

The device features an embedded programmable voltage detector (PVD) that monitors the  $V_{DD}/V_{DDA}$  power supply and compares it to the  $V_{PVD}$  threshold. An interrupt can be generated when  $V_{DD}/V_{DDA}$  drops below the  $V_{PVD}$  threshold and/or when  $V_{DD}/V_{DDA}$  is higher than the  $V_{PVD}$  threshold. The interrupt service routine can then generate a warning message and/or put the MCU into a safe state. The PVD is enabled by software.

### 2.3.11 Voltage regulator

The regulator has three operation modes: main (MR), low power (LPR) and power down.

- MR is used in the nominal regulation mode (Run)
- LPR is used in the Stop modes.
- Power down is used in Standby mode: the regulator output is in high impedance: the kernel circuitry is powered down, inducing zero consumption (but the contents of the registers and SRAM are lost)

This regulator is always enabled after reset. It is disabled in Standby mode.

### 2.3.12 Low-power modes

The STM32F105xx and STM32F107xx connectivity line supports three low-power modes to achieve the best compromise between low power consumption, short startup time and available wakeup sources:

- **Sleep mode**  
In Sleep mode, only the CPU is stopped. All peripherals continue to operate and can wake up the CPU when an interrupt/event occurs.
- **Stop mode**  
Stop mode achieves the lowest power consumption while retaining the content of SRAM and registers. All clocks in the  $1.8$  V domain are stopped, the PLL, the HSI RC and the HSE crystal oscillators are disabled. The voltage regulator can also be put either in normal or in low-power mode.  
The device can be woken up from Stop mode by any of the EXTI line. The EXTI line source can be one of the 16 external lines, the PVD output, the RTC alarm or the USB OTG FS wakeup.



- **Standby mode**

The Standby mode is used to achieve the lowest power consumption. The internal voltage regulator is switched off so that the entire 1.8 V domain is powered off. The PLL, the HSI RC and the HSE crystal oscillators are also switched off. After entering Standby mode, SRAM and register contents are lost except for registers in the Backup domain and Standby circuitry.

The device exits Standby mode when an external reset (NRST pin), an IWDG reset, a rising edge on the WKUP pin, or an RTC alarm occurs.

*Note:* The RTC, the IWDG, and the corresponding clock sources are not stopped by entering Stop or Standby mode.

### 2.3.13 DMA

The flexible 12-channel general-purpose DMAs (7 channels for DMA1 and 5 channels for DMA2) are able to manage memory-to-memory, peripheral-to-memory and memory-to-peripheral transfers. The two DMA controllers support circular buffer management, removing the need for user code intervention when the controller reaches the end of the buffer.

Each channel is connected to dedicated hardware DMA requests, with support for software trigger on each channel. Configuration is made by software and transfer sizes between source and destination are independent.

The DMA can be used with the main peripherals: SPI, I<sup>2</sup>C, USART, general-purpose, basic and advanced control timers TIMx, DAC, I<sup>2</sup>S and ADC.

In the STM32F107xx, there is a DMA controller dedicated for use with the Ethernet (see [Section 2.3.20: Ethernet MAC interface with dedicated DMA and IEEE 1588 support](#) for more information).

### 2.3.14 RTC (real-time clock) and backup registers

The RTC and the backup registers are supplied through a switch that takes power either on V<sub>DD</sub> supply when present or through the V<sub>BAT</sub> pin. The backup registers are forty-two 16-bit registers used to store 84 bytes of user application data when V<sub>DD</sub> power is not present. They are not reset by a system or power reset, and they are not reset when the device wakes up from the Standby mode.

The real-time clock provides a set of continuously running counters which can be used with suitable software to provide a clock calendar function, and provides an alarm interrupt and a periodic interrupt. It is clocked by a 32.768 kHz external crystal, resonator or oscillator, the internal low power RC oscillator or the high-speed external clock divided by 128. The internal low-speed RC has a typical frequency of 40 kHz. The RTC can be calibrated using an external 512 Hz output to compensate for any natural quartz deviation. The RTC features a 32-bit programmable counter for long term measurement using the Compare register to generate an alarm. A 20-bit prescaler is used for the time base clock and is by default configured to generate a time base of 1 second from a clock at 32.768 kHz.

For more information, refer to AN2604: “*STM32F101xx and STM32F103xx RTC calibration*”, available from [www.st.com](http://www.st.com).



### 2.3.15 Timers and watchdogs

The STM32F105xx and STM32F107xx devices include an advanced-control timer, four general-purpose timers, two basic timers, two watchdog timers and a SysTick timer.

[Table 4](#) compares the features of the general-purpose and basic timers.

**Table 4. Timer feature comparison**

Timer	Counter resolution	Counter type	Prescaler factor	DMA request generation	Capture/compare channels	Complementary outputs
TIM1	16-bit	Up, down, up/down	Any integer between 1 and 65536	Yes	4	Yes
TIMx (TIM2, TIM3, TIM4, TIM5)	16-bit	Up, down, up/down	Any integer between 1 and 65536	Yes	4	No
TIM6, TIM7	16-bit	Up	Any integer between 1 and 65536	Yes	0	No

#### Advanced-control timer (TIM1)

The advanced control timer (TIM1) can be seen as a three-phase PWM multiplexed on 6 channels. It has complementary PWM outputs with programmable inserted dead-times. It can also be seen as a complete general-purpose timer. The 4 independent channels can be used for:

- Input capture
- Output compare
- PWM generation (edge or center-aligned modes)
- One-pulse mode output

If configured as a standard 16-bit timer, it has the same features as the TIMx timer. If configured as the 16-bit PWM generator, it has full modulation capability (0-100%).

The counter can be frozen in debug mode.

Many features are shared with those of the standard TIM timers which have the same architecture. The advanced control timer can therefore work together with the TIM timers via the Timer Link feature for synchronization or event chaining.

#### General-purpose timers (TIMx)

There are up to 4 synchronizable standard timers (TIM2, TIM3, TIM4 and TIM5) embedded in the STM32F105xx and STM32F107xx connectivity line devices. These timers are based on a 16-bit auto-reload up/down counter, a 16-bit prescaler and feature 4 independent channels each for input capture/output compare, PWM or one pulse mode output. This gives up to 16 input captures / output compares / PWMs on the largest packages. They can work together with the Advanced Control timer via the Timer Link feature for synchronization or event chaining.

The counter can be frozen in debug mode.





Any of the standard timers can be used to generate PWM outputs. Each of the timers has independent DMA request generations.

### Basic timers TIM6 and TIM7

These timers are mainly used for DAC trigger generation. They can also be used as a generic 16-bit time base.

### Independent watchdog

The independent watchdog is based on a 12-bit downcounter and 8-bit prescaler. It is clocked from an independent 40 kHz internal RC and as it operates independently from the main clock, it can operate in Stop and Standby modes. It can be used either as a watchdog to reset the device when a problem occurs, or as a free running timer for application timeout management. It is hardware or software configurable through the option bytes. The counter can be frozen in debug mode.

### Window watchdog

The window watchdog is based on a 7-bit downcounter that can be set as free running. It can be used as a watchdog to reset the device when a problem occurs. It is clocked from the main clock. It has an early warning interrupt capability and the counter can be frozen in debug mode.

### SysTick timer

This timer is dedicated to real-time operating systems, but could also be used as a standard down counter. It features:

- A 24-bit down counter
- Autoreload capability
- Maskable system interrupt generation when the counter reaches 0.
- Programmable clock source

## 2.3.16 I<sup>2</sup>C bus

Up to two I<sup>2</sup>C bus interfaces can operate in multimaster and slave modes. They can support standard and fast modes.

They support 7/10-bit addressing mode and 7-bit dual addressing mode (as slave). A hardware CRC generation/verification is embedded.

They can be served by DMA and they support SMBus 2.0/PMBus.

## 2.3.17 Universal synchronous/asynchronous receiver transmitters (USARTs)

The STM32F105xx and STM32F107xx connectivity line embeds three universal synchronous/asynchronous receiver transmitters (USART1, USART2 and USART3) and two universal asynchronous receiver transmitters (UART4 and UART5).

These five interfaces provide asynchronous communication, IrDA SIR ENDEC support, multiprocessor communication mode, single-wire half-duplex communication mode and have LIN Master/Slave capability.

The USART1 interface is able to communicate at speeds of up to 4.5 Mbit/s. The other available interfaces communicate at up to 2.25 Mbit/s.



USART1, USART2 and USART3 also provide hardware management of the CTS and RTS signals, Smart Card mode (ISO 7816 compliant) and SPI-like communication capability. All interfaces can be served by the DMA controller except for UART5.

### 2.3.18 Serial peripheral interface (SPI)

Up to three SPIs are able to communicate up to 18 Mbits/s in slave and master modes in full-duplex and simplex communication modes. The 3-bit prescaler gives 8 master mode frequencies and the frame is configurable to 8 bits or 16 bits. The hardware CRC generation/verification supports basic SD Card/MMC/SDHC<sup>(a)</sup> modes.

All SPIs can be served by the DMA controller.

### 2.3.19 Inter-integrated sound (I<sup>2</sup>S)

Two standard I<sup>2</sup>S interfaces (multiplexed with SPI2 and SPI3) are available, that can be operated in master or slave mode. These interfaces can be configured to operate with 16/32 bit resolution, as input or output channels. Audio sampling frequencies from 8 kHz up to 96 kHz are supported. When either or both of the I<sup>2</sup>S interfaces is/are configured in master mode, the master clock can be output to the external DAC/CODEC at 256 times the sampling frequency with less than 0.5% accuracy error owing to the advanced clock controller (see [Section 2.3.7: Clocks and startup](#)).

Refer to the “Audio frequency precision” tables provided in the “Serial peripheral interface (SPI)” section of the STM32F10xxx reference manual.

### 2.3.20 Ethernet MAC interface with dedicated DMA and IEEE 1588 support

Peripheral not available on STM32F105xx devices.

The STM32F107xx devices provide an IEEE-802.3-2002-compliant media access controller (MAC) for ethernet LAN communications through an industry-standard media-independent interface (MII) or a reduced media-independent interface (RMII). The STM32F107xx requires an external physical interface device (PHY) to connect to the physical LAN bus (twisted-pair, fiber, etc.). the PHY is connected to the STM32F107xx MII port using as many as 17 signals (MII) or 9 signals (RMII) and can be clocked using the 25 MHz (MII) or 50 MHz (RMII) output from the STM32F107xx.

The STM32F107xx includes the following features:

- Supports 10 and 100 Mbit/s rates
- Dedicated DMA controller allowing high-speed transfers between the dedicated SRAM and the descriptors (see the STM32F105xx/STM32F107xx reference manual for details)
- Tagged MAC frame support (VLAN support)
- Half-duplex (CSMA/CD) and full-duplex operation
- MAC control sublayer (control frames) support

---

a. SDHC = Secure digital high capacity.



- 32-bit CRC generation and removal
- Several address filtering modes for physical and multicast address (multicast and group addresses)
- 32-bit status code for each transmitted or received frame
- Internal FIFOs to buffer transmit and receive frames. The transmit FIFO and the receive FIFO are both 2 Kbytes, that is 4 Kbytes in total
- Supports hardware PTP (precision time protocol) in accordance with IEEE 1588 with the timestamp comparator connected to the TIM2 trigger input
- Triggers interrupt when system time becomes greater than target time

### 2.3.21 Controller area network (CAN)

The two CANs are compliant with the 2.0A and B (active) specifications with a bitrate up to 1 Mbit/s. They can receive and transmit standard frames with 11-bit identifiers as well as extended frames with 29-bit identifiers. Each CAN has three transmit mailboxes, two receive FIFOs with 3 stages and 28 shared scalable filter banks (all of them can be used even if one CAN is used). The 256 bytes of SRAM which are allocated for each CAN (512 bytes in total) are not shared with any other peripheral.

### 2.3.22 Universal serial bus on-the-go full-speed (USB OTG FS)

The STM32F105xx and STM32F107xx connectivity line devices embed a USB OTG full-speed (12 Mb/s) device/host/OTG peripheral with integrated transceivers. The USB OTG FS peripheral is compliant with the USB 2.0 specification and with the OTG 1.0 specification. It has software-configurable endpoint setting and supports suspend/resume. The USB OTG full-speed controller requires a dedicated 48 MHz clock that is generated by a PLL connected to the HSE oscillator. The major features are:

- 1.25 KB of SRAM used exclusively by the endpoints (not shared with any other peripheral)
- 4 bidirectional endpoints
- HNP/SNP/IP inside (no need for any external resistor)
- for OTG/Host modes, a power switch is needed in case bus-powered devices are connected
- the SOF output can be used to synchronize the external audio DAC clock in isochronous mode
- in accordance with the USB 2.0 Specification, the supported transfer speeds are:
  - in Host mode: full speed and low speed
  - in Device mode: full speed

### 2.3.23 GPIOs (general-purpose inputs/outputs)

Each of the GPIO pins can be configured by software as output (push-pull or open-drain), as input (with or without pull-up or pull-down) or as peripheral alternate function. Most of the GPIO pins are shared with digital or analog alternate functions. All GPIOs are high current-capable.

The I/Os alternate function configuration can be locked if needed following a specific sequence in order to avoid spurious writing to the I/Os registers.

I/Os on APB2 with up to 18 MHz toggling speed



### 2.3.24 Remap capability

This feature allows the use of a maximum number of peripherals in a given application. Indeed, alternate functions are available not only on the default pins but also on other specific pins onto which they are remappable. This has the advantage of making board design and port usage much more flexible.

For details refer to [Table 5: Pin definitions](#); it shows the list of remappable alternate functions and the pins onto which they can be remapped. See the STM32F10xxx reference manual for software considerations.

### 2.3.25 ADCs (analog-to-digital converters)

Two 12-bit analog-to-digital converters are embedded into STM32F105xx and STM32F107xx connectivity line devices and each ADC shares up to 16 external channels, performing conversions in single-shot or scan modes. In scan mode, automatic conversion is performed on a selected group of analog inputs.

Additional logic functions embedded in the ADC interface allow:

- Simultaneous sample and hold
- Interleaved sample and hold
- Single shunt

The ADC can be served by the DMA controller.

An analog watchdog feature allows very precise monitoring of the converted voltage of one, some or all selected channels. An interrupt is generated when the converted voltage is outside the programmed thresholds.

The events generated by the standard timers (TIMx) and the advanced-control timer (TIM1) can be internally connected to the ADC start trigger and injection trigger, respectively, to allow the application to synchronize A/D conversion and timers.

### 2.3.26 DAC (digital-to-analog converter)

The two 12-bit buffered DAC channels can be used to convert two digital signals into two analog voltage signal outputs. The chosen design structure is composed of integrated resistor strings and an amplifier in inverting configuration.

This dual digital Interface supports the following features:

- two DAC converters: one for each output channel
- 8-bit or 12-bit monotonic output
- left or right data alignment in 12-bit mode
- synchronized update capability
- noise-wave generation
- triangular-wave generation
- dual DAC channel independent or simultaneous conversions
- DMA capability for each channel
- external triggers for conversion
- input voltage reference  $V_{REF+}$





Eight DAC trigger inputs are used in the STM32F105xx and STM32F107xx connectivity line family. The DAC channels are triggered through the timer update outputs that are also connected to different DMA channels.

### 2.3.27 Temperature sensor

The temperature sensor has to generate a voltage that varies linearly with temperature. The conversion range is between  $2\text{ V} < V_{DDA} < 3.6\text{ V}$ . The temperature sensor is internally connected to the ADC1\_IN16 input channel which is used to convert the sensor output voltage into a digital value.

### 2.3.28 Serial wire JTAG debug port (SWJ-DP)

The ARM SWJ-DP Interface is embedded, and is a combined JTAG and serial wire debug port that enables either a serial wire debug or a JTAG probe to be connected to the target. The JTAG TMS and TCK pins are shared respectively with SWDIO and SWCLK and a specific sequence on the TMS pin is used to switch between JTAG-DP and SW-DP.

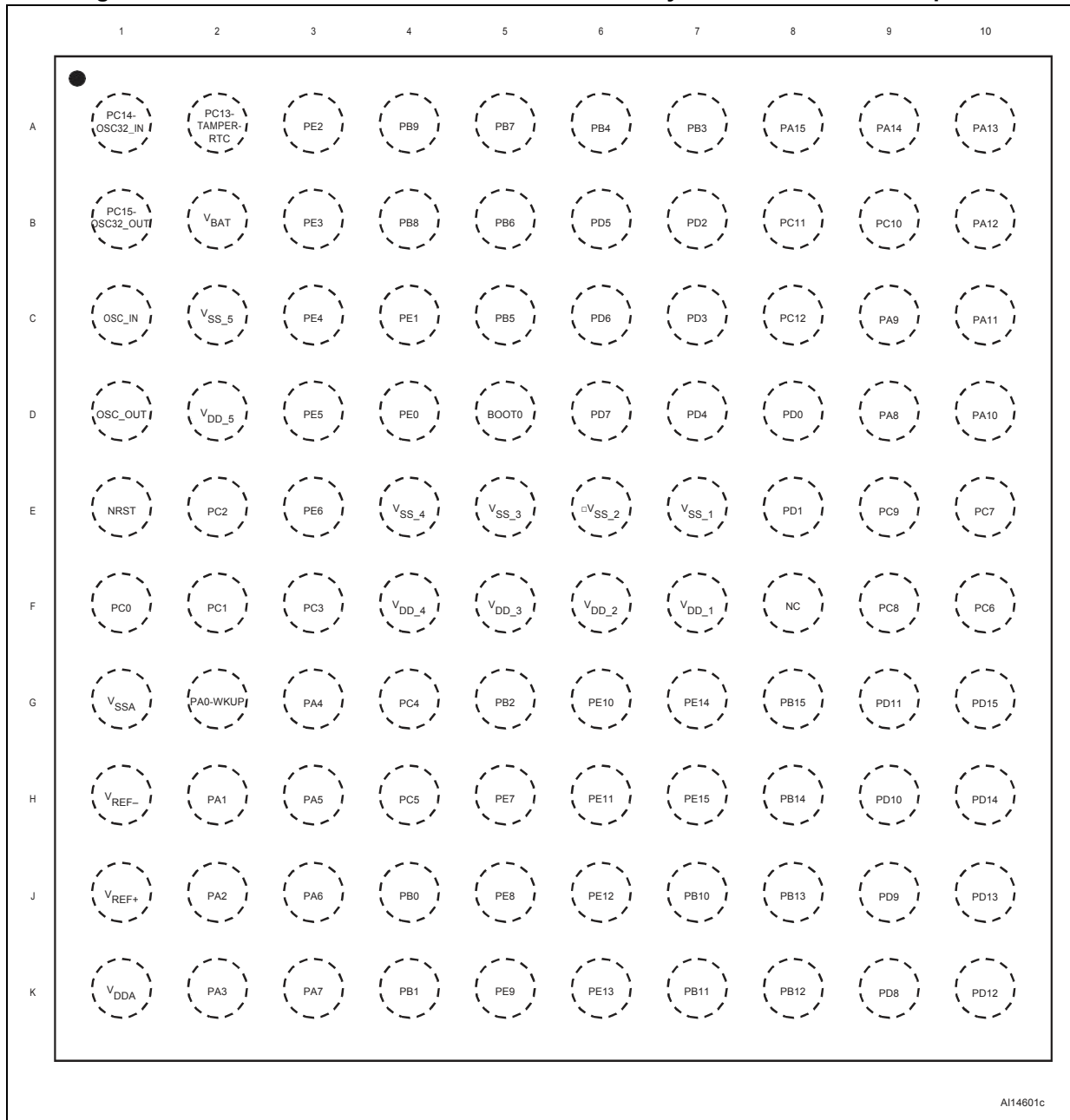
### 2.3.29 Embedded Trace Macrocell™

The ARM® Embedded Trace Macrocell provides a greater visibility of the instruction and data flow inside the CPU core by streaming compressed data at a very high rate from the STM32F10xxx through a small number of ETM pins to an external hardware trace port analyzer (TPA) device. The TPA is connected to a host computer using USB, Ethernet, or any other high-speed channel. Real-time instruction and data flow activity can be recorded and then formatted for display on the host computer running debugger software. TPA hardware is commercially available from common development tool vendors. It operates with third party debugger software tools.



### 3 Pinouts and pin description

Figure 2. STM32F105xx and STM32F107xx connectivity line BGA100 ballout top view



A114601c



Figure 3. STM32F105xx and STM32F107xx connectivity line LQFP100 pinout

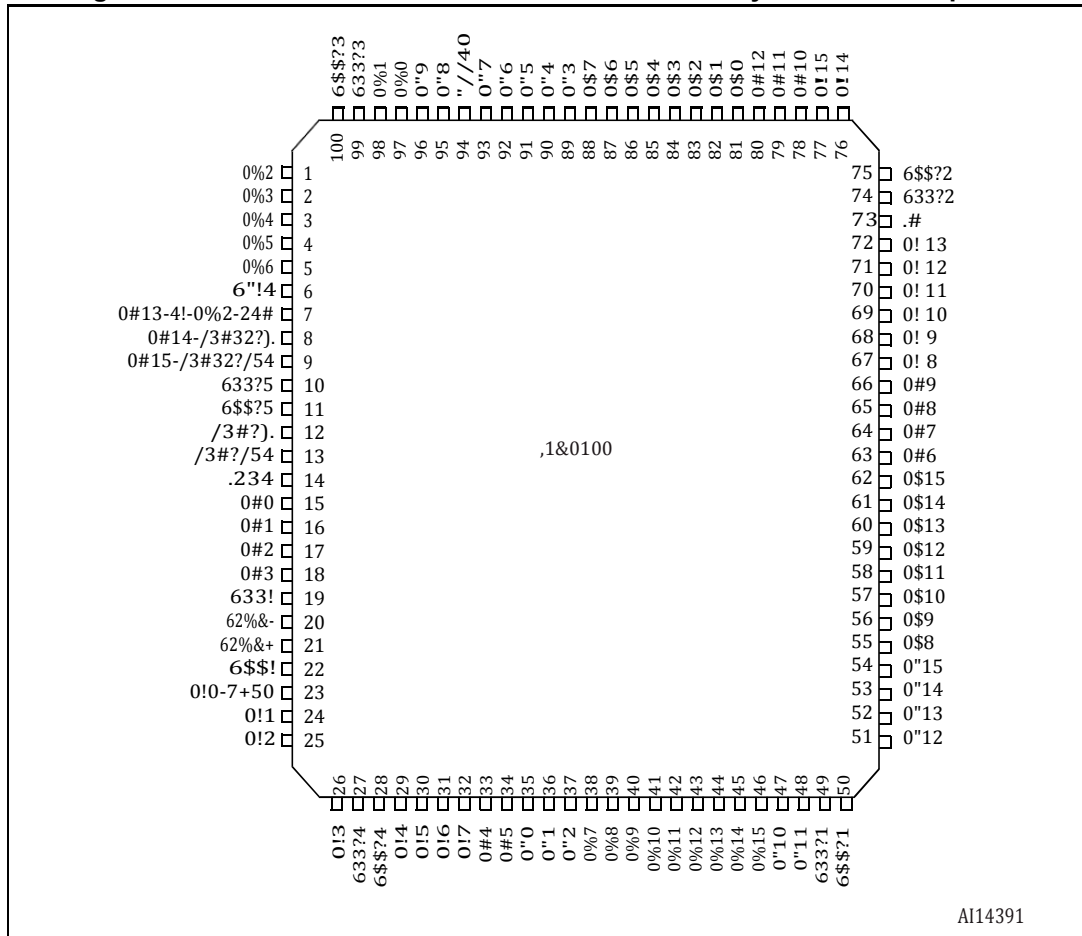




Figure 4. STM32F105xx and STM32F107xx connectivity line LQFP64 pinout

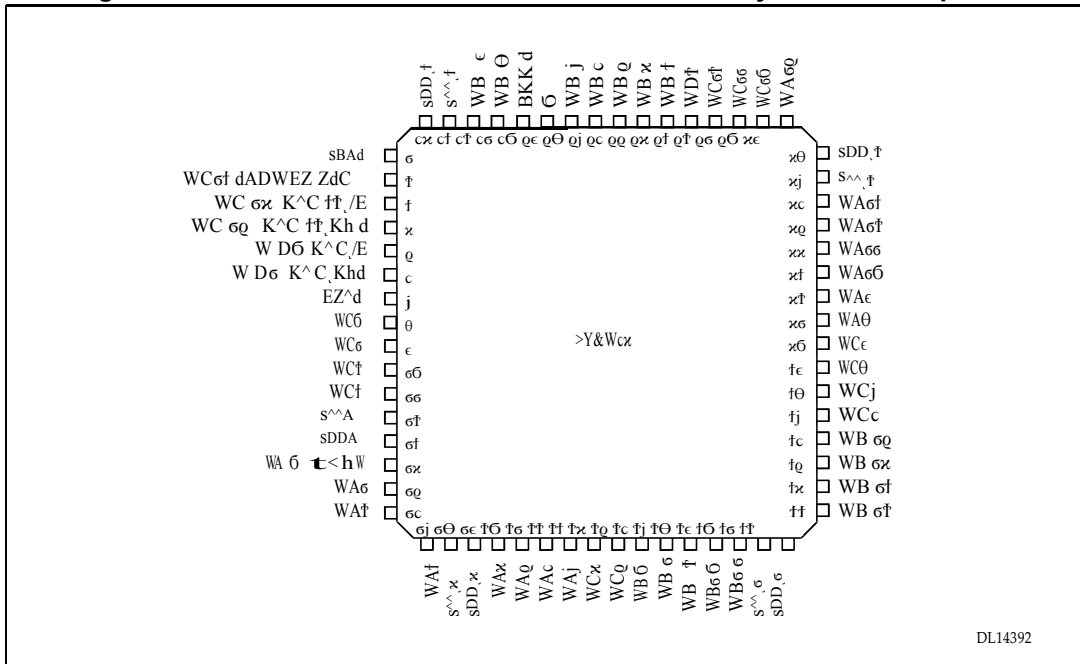






Table 5. Pin definitions

Pins			Pin name	Type <sup>(1)</sup>	I / O Level <sup>(2)</sup>	Main function <sup>(3)</sup> (after reset)	Alternate functions <sup>(4)</sup>	
BGA100	LQFP64	LQFP100					Default	Remap
A3	-	1	PE2	I/O	FT	PE2	TRACECK	-
B3	-	2	PE3	I/O	FT	PE3	TRACED0	-
C3	-	3	PE4	I/O	FT	PE4	TRACED1	-
D3	-	4	PE5	I/O	FT	PE5	TRACED2	-
E3	-	5	PE6	I/O	FT	PE6	TRACED3	-
B2	1	6	V <sub>BAT</sub>	S	-	V <sub>BAT</sub>	-	-
A2	2	7	PC13-TAMPER-RTC <sup>(5)</sup>	I/O	-	PC13 <sup>(6)</sup>	TAMPER-RTC	-
A1	3	8	PC14-OSC32_IN <sup>(5)</sup>	I/O	-	PC14 <sup>(6)</sup>	OSC32_IN	-
B1	4	9	PC15-OSC32_OUT <sup>(5)</sup>	I/O	-	PC15 <sup>(6)</sup>	OSC32_OUT	-
C2	-	10	V <sub>SS_5</sub>	S	-	V <sub>SS_5</sub>	-	-
D2	-	11	V <sub>DD_5</sub>	S	-	V <sub>DD_5</sub>	-	-
C1	5	12	OSC_IN	I	-	OSC_IN	-	-
D1	6	13	OSC_OUT	O	-	OSC_OUT	-	-
E1	7	14	NRST	I/O	-	NRST	-	-
F1	8	15	PC0	I/O	-	PC0	ADC12_IN10	-
F2	9	16	PC1	I/O	-	PC1	ADC12_IN11/ ETH_MII_MDC/ ETH_RMII_MDC	-
E2	10	17	PC2	I/O	-	PC2	ADC12_IN12/ ETH_MII_TXD2	-
F3	11	18	PC3	I/O	-	PC3	ADC12_IN13/ ETH_MII_TX_CLK	-
G1	12	19	V <sub>SSA</sub>	S	-	V <sub>SSA</sub>	-	-
H1	-	20	V <sub>REF-</sub>	S	-	V <sub>REF-</sub>	-	-
J1	-	21	V <sub>REF+</sub>	S	-	V <sub>REF+</sub>	-	-
K1	13	22	V <sub>DDA</sub>	S	-	V <sub>DDA</sub>	-	-
G2	14	23	PA0-WKUP	I/O	-	PA0	WKUP/USART2_CTS <sup>(7)</sup> ADC12_IN10/TIM2_CH1_ETR TIM5_CH1/ ETH_MII_CRS_WKUP	-



Table 5. Pin definitions (continued)

Pins			Pin name	Type <sup>(1)</sup>	I / O Level <sup>(2)</sup>	Main function <sup>(3)</sup> (after reset)	Alternate functions <sup>(4)</sup>	
BGA100	LQFP64	LQFP100					Default	Remap
H2	15	24	PA1	I/O	-	PA1	USART2_RTS <sup>(7)</sup> / ADC12_IN1/ TIM5_CH2 /TIM2_CH2 <sup>(7)</sup> / ETH_MII_RX_CLK/ ETH_RMII_REF_CLK	-
J2	16	25	PA2	I/O	-	PA2	USART2_TX <sup>(7)</sup> / TIM5_CH3/ADC12_IN2/ TIM2_CH3 <sup>(7)</sup> / ETH_MII_MDIO/ ETH_RMII_MDIO	-
K2	17	26	PA3	I/O	-	PA3	USART2_RX <sup>(7)</sup> / TIM5_CH4/ADC12_IN3 / TIM2_CH4 <sup>(7)</sup> / ETH_MII_COL	-
E4	18	27	V <sub>SS_4</sub>	S	-	V <sub>SS_4</sub>	-	-
F4	19	28	V <sub>DD_4</sub>	S	-	V <sub>DD_4</sub>	-	-
G3	20	29	PA4	I/O	-	PA4	SPI1_NSS <sup>(7)</sup> /DAC_OUT1 / USART2_CK <sup>(7)</sup> / ADC12_IN4	SPI3_NSS/I2S3_WS
H3	21	30	PA5	I/O	-	PA5	SPI1_SCK <sup>(7)</sup> / DAC_OUT2 / ADC12_IN5	-
J3	22	31	PA6	I/O	-	PA6	SPI1_MISO <sup>(7)</sup> /ADC12_IN6 / TIM3_CH1 <sup>(7)</sup>	TIM1_BKIN
K3	23	32	PA7	I/O	-	PA7	SPI1_MOSI <sup>(7)</sup> /ADC12_IN7 / TIM3_CH2 <sup>(7)</sup> / ETH_MII_RX_DV <sup>(8)</sup> / ETH_RMII_CRS_DV	TIM1_CH1N
G4	24	33	PC4	I/O	-	PC4	ADC12_IN14/ ETH_MII_RXD0 <sup>(8)</sup> / ETH_RMII_RXD0	-
H4	25	34	PC5	I/O	-	PC5	ADC12_IN15/ ETH_MII_RXD1 <sup>(8)</sup> / ETH_RMII_RXD1	-
J4	26	35	PB0	I/O	-	PB0	ADC12_IN8/TIM3_CH3/ ETH_MII_RXD2 <sup>(8)</sup>	TIM1_CH2N
K4	27	36	PB1	I/O	-	PB1	ADC12_IN9/TIM3_CH4 <sup>(7)</sup> / ETH_MII_RXD3 <sup>(8)</sup>	TIM1_CH3N
G5	28	37	PB2	I/O	FT	PB2/BOOT1	-	-
H5	-	38	PE7	I/O	FT	PE7	-	TIM1_ETR
J5	-	39	PE8	I/O	FT	PE8	-	TIM1_CH1N



Table 5. Pin definitions (continued)

Pins			Pin name	Type(1)	I / O Level(2)	Main function(3) (after reset)	Alternate functions(4)	
BGA100	LQFP64	LQFP100					Default	Remap
K5	-	40	PE9	I/O	FT	PE9	-	TIM1_CH1
-	-	-	V <sub>SS_7</sub>	S	-	-	-	-
-	-	-	V <sub>DD_7</sub>	S	-	-	-	-
G6	-	41	PE10	I/O	FT	PE10	-	TIM1_CH2N
H6	-	42	PE11	I/O	FT	PE11	-	TIM1_CH2
J6	-	43	PE12	I/O	FT	PE12	-	TIM1_CH3N
K6	-	44	PE13	I/O	FT	PE13	-	TIM1_CH3
G7	-	45	PE14	I/O	FT	PE14	-	TIM1_CH4
H7	-	46	PE15	I/O	FT	PE15	-	TIM1_BKIN
J7	29	47	PB10	I/O	FT	PB10	I2C2_SCL <sup>(8)</sup> /USART3_TX <sup>(7)</sup> / ETH_MII_RX_ER	TIM2_CH3
K7	30	48	PB11	I/O	FT	PB11	I2C2_SDA <sup>(8)</sup> /USART3_RX <sup>(7)</sup> / ETH_MII_TX_EN/ ETH_RMII_TX_EN	TIM2_CH4
E7	31	49	V <sub>SS_1</sub>	S	-	V <sub>SS_1</sub>	-	-
F7	32	50	V <sub>DD_1</sub>	S	-	V <sub>DD_1</sub>	-	-
K8	33	51	PB12	I/O	FT	PB12	SPI2_NSS <sup>(8)</sup> /I2S2_WS <sup>(8)</sup> / I2C2_SMBA <sup>(8)</sup> / USART3_CK <sup>(7)</sup> / TIM1_BKIN <sup>(7)</sup> / CAN2_RX/ ETH_MII_TXD0/ ETH_RMII_TXD0	-
J8	34	52	PB13	I/O	FT	PB13	SPI2_SCK <sup>(8)</sup> / I2S2_CK <sup>(8)</sup> / USART3_CTS <sup>(7)</sup> / TIM1_CH1N/CAN2_TX/ ETH_MII_TXD1/ ETH_RMII_TXD1	-
H8	35	53	PB14	I/O	FT	PB14	SPI2_MISO <sup>(8)</sup> / TIM1_CH2N / USART3_RTS <sup>(7)</sup>	-
G8	36	54	PB15	I/O	FT	PB15	SPI2_MOSI <sup>(8)</sup> / I2S2_SD <sup>(8)</sup> / TIM1_CH3N <sup>(7)</sup>	-
K9	-	55	PD8	I/O	FT	PD8	-	USART3_TX/ ETH_MII_RX_DV/ ETH_RMII_CRD_DV



Table 5. Pin definitions (continued)

Pins			Pin name	Type(1)	I / O Level(2)	Main function(3) (after reset)	Alternate functions(4)		
BGA100	LQFP64	LQFP100					Default	Remap	
J9	-	56	PD9	I/O	FT	PD9	-	USART3_RX/ ETH_MII_RXD0/ ETH_RMII_RXD0	
H9	-	57	PD10	I/O	FT	PD10	-	USART3_CK/ ETH_MII_RXD1/ ETH_RMII_RXD1	
G9	-	58	PD11	I/O	FT	PD11	-	USART3_CTS/ ETH_MII_RXD2	
K10	-	59	PD12	I/O	FT	PD12	-	TIM4_CH1 / USART3_RTS/ ETH_MII_RXD3	
J10	-	60	PD13	I/O	FT	PD13	-	TIM4_CH2	
H10	-	61	PD14	I/O	FT	PD14	-	TIM4_CH3	
G10	-	62	PD15	I/O	FT	PD15	-	TIM4_CH4	
F10	37	63	PC6	I/O	FT	PC6	I2S2_MCK/	TIM3_CH1	
E10	38	64	PC7	I/O	FT	PC7	I2S3_MCK	TIM3_CH2	
F9	39	65	PC8	I/O	FT	PC8	-	TIM3_CH3	
E9	40	66	PC9	I/O	FT	PC9	-	TIM3_CH4	
D9	41	67	PA8	I/O	FT	PA8	USART1_CK/OTG_FS_SOF / TIM1_CH1(8)/MCO	-	
C9	42	68	PA9	I/O	FT	PA9	USART1_TX(7)/ TIM1_CH2(7)/ OTG_FS_VBUS	-	
D10	43	69	PA10	I/O	FT	PA10	USART1_RX(7)/ TIM1_CH3(7)/OTG_FS_ID	-	
C10	44	70	PA11	I/O	FT	PA11	USART1_CTS / CAN1_RX / TIM1_CH4(7)/OTG_FS_DM	-	
B10	45	71	PA12	I/O	FT	PA12	USART1_RTS / OTG_FS_DP / CAN1_TX(7) / TIM1_ETR(7)	-	
A10	46	72	PA13	I/O	FT	JTMS-SWDIO	-	PA13	
F8	-	73	Not connected					-	-
E6	47	74	V <sub>SS_2</sub>	S	-	V <sub>SS_2</sub>	-	-	
F6	48	75	V <sub>DD_2</sub>	S	-	V <sub>DD_2</sub>	-	-	
A9	49	76	PA14	I/O	FT	JTCK-SWCLK	-	PA14	





Table 5. Pin definitions (continued)

Pins			Pin name	Type <sup>(1)</sup>	I / O Level <sup>(2)</sup>	Main function <sup>(3)</sup> (after reset)	Alternate functions <sup>(4)</sup>	
BGA100	LQFP64	LQFP100					Default	Remap
A8	50	77	PA15	I/O	FT	JTDI	SPI3_NSS / I2S3_WS	TIM2_CH1_ETR / PA15 SPI1_NSS
B9	51	78	PC10	I/O	FT	PC10	UART4_TX	USART3_TX/ SPI3_SCK/I2S3_CK
B8	52	79	PC11	I/O	FT	PC11	UART4_RX	USART3_RX/ SPI3_MISO
C8	53	80	PC12	I/O	FT	PC12	UART5_TX	USART3_CK/ SPI3_MOSI/I2S3_SD
D8	-	81	PD0	I/O	FT	PD0	-	OSC_IN <sup>(9)</sup> /CAN1_RX
E8	-	82	PD1	I/O	FT	PD1	-	OSC_OUT <sup>(9)</sup> /CAN1_TX
B7	54	83	PD2	I/O	FT	PD2	TIM3_ETR / UART5_RX	
C7	-	84	PD3	I/O	FT	PD3	-	USART2_CTS
D7	-	85	PD4	I/O	FT	PD4	-	USART2_RTS
B6	-	86	PD5	I/O	FT	PD5	-	USART2_TX
C6	-	87	PD6	I/O	FT	PD6	-	USART2_RX
D6	-	88	PD7	I/O	FT	PD7	-	USART2_CK
A7	55	89	PB3	I/O	FT	JTDO	SPI3_SCK / I2S3_CK	PB3 / TRACESWO/ TIM2_CH2 / SPI1_SCK
A6	56	90	PB4	I/O	FT	NJTRST	SPI3_MISO	PB4 / TIM3_CH1/ SPI1_MISO
C5	57	91	PB5	I/O	-	PB5	I2C1_SMBA / SPI3_MOSI / ETH_MII_PPS_OUT / I2S3_SD ETH_RMII_PPS_OUT	TIM3_CH2/SPI1_MOSI/ CAN2_RX
B5	58	92	PB6	I/O	FT	PB6	I2C1_SCL <sup>(7)</sup> /TIM4_CH1 <sup>(7)</sup>	USART1_TX/CAN2_TX
A5	59	93	PB7	I/O	FT	PB7	I2C1_SDA <sup>(7)</sup> /TIM4_CH2 <sup>(7)</sup>	USART1_RX
D5	60	94	BOOT0	I	-	BOOT0	-	-
B4	61	95	PB8	I/O	FT	PB8	TIM4_CH3 <sup>(7)</sup> / ETH_MII_TXD3	I2C1_SCL/CAN1_RX
A4	62	96	PB9	I/O	FT	PB9	TIM4_CH4 <sup>(7)</sup>	I2C1_SDA / CAN1_TX
D4	-	97	PE0	I/O	FT	PE0	TIM4_ETR	-
C4	-	98	PE1	I/O	FT	PE1	-	-
E5	63	99	V <sub>SS_3</sub>	S	-	V <sub>SS_3</sub>	-	-
F5	64	100	V <sub>DD_3</sub>	S	-	V <sub>DD_3</sub>	-	-



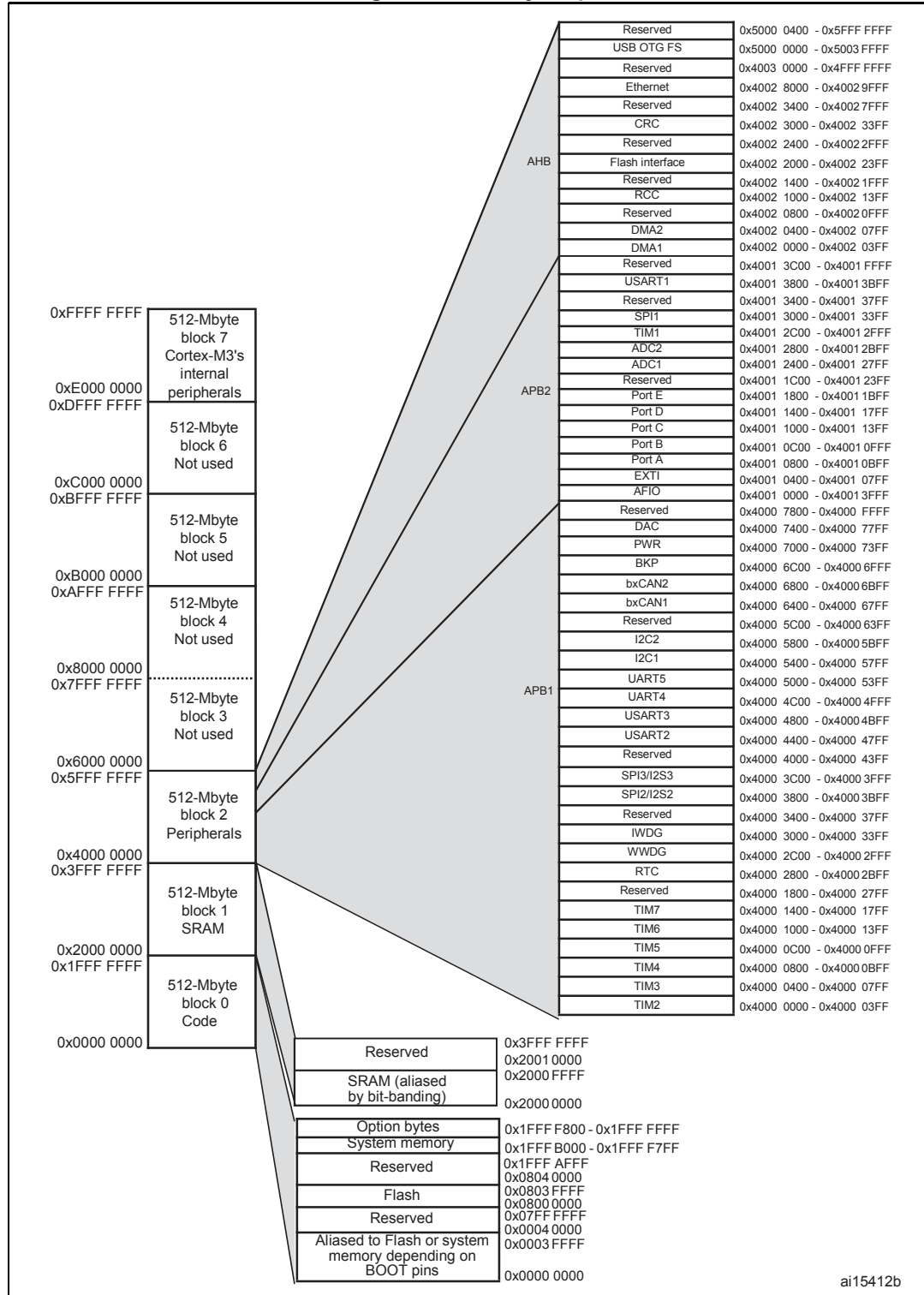
1. I = input, O = output, S = supply, HiZ = high impedance.
2. FT = 5 V tolerant. All I/Os are  $V_{DD}$  capable.
3. Function availability depends on the chosen device.
4. If several peripherals share the same I/O pin, to avoid conflict between these alternate functions only one peripheral should be enabled at a time through the peripheral clock enable bit (in the corresponding RCC peripheral clock enable register).
5. PC13, PC14 and PC15 are supplied through the power switch, and so their use in output mode is limited: they can be used only in output 2 MHz mode with a maximum load of 30 pF and only one pin can be put in output mode at a time.
6. Main function after the first backup domain power-up. Later on, it depends on the contents of the Backup registers even after reset (because these registers are not reset by the main reset). For details on how to manage these IOs, refer to the Battery backup domain and BKP register description sections in the STM32F10xxx reference manual, available from the STMicroelectronics website: [www.st.com](http://www.st.com).
7. This alternate function can be remapped by software to some other port pins (if available on the used package). For more details, refer to the Alternate function I/O and debug configuration section in the STM32F10xxx reference manual, available from the STMicroelectronics website: [www.st.com](http://www.st.com).
8. SPI2/I2S2 and I2C2 are not available when the Ethernet is being used.
9. For the LQFP64 package, the pins number 5 and 6 are configured as OSC\_IN/OSC\_OUT after reset, however the functionality of PD0 and PD1 can be remapped by software on these pins. For the LQFP100 and BGA100 packages, PD0 and PD1 are available by default, so there is no need for remapping. For more details, refer to Alternate function I/O and debug configuration section in the STM32F10xxx reference manual.



# 4 Memory mapping

The memory map is shown in *Figure 5*.

Figure 5. Memory map





## 5 Electrical characteristics

### 5.1 Parameter conditions

Unless otherwise specified, all voltages are referenced to  $V_{SS}$ .

#### 5.1.1 Minimum and maximum values

Unless otherwise specified the minimum and maximum values are guaranteed in the worst conditions of ambient temperature, supply voltage and frequencies by tests in production on 100% of the devices with an ambient temperature at  $T_A = 25\text{ }^\circ\text{C}$  and  $T_A = T_{Amax}$  (given by the selected temperature range).

Data based on characterization results, design simulation and/or technology characteristics are indicated in the table footnotes and are not tested in production. Based on characterization, the minimum and maximum values refer to sample tests and represent the mean value plus or minus three times the standard deviation ( $\text{mean} \pm 3\sigma$ ).

#### 5.1.2 Typical values

Unless otherwise specified, typical data are based on  $T_A = 25\text{ }^\circ\text{C}$ ,  $V_{DD} = 3.3\text{ V}$  (for the  $2\text{ V} \leq V_{DD} \leq 3.6\text{ V}$  voltage range). They are given only as design guidelines and are not tested.

Typical ADC accuracy values are determined by characterization of a batch of samples from a standard diffusion lot over the full temperature range, where 95% of the devices have an error less than or equal to the value indicated ( $\text{mean} \pm 2\sigma$ ).

#### 5.1.3 Typical curves

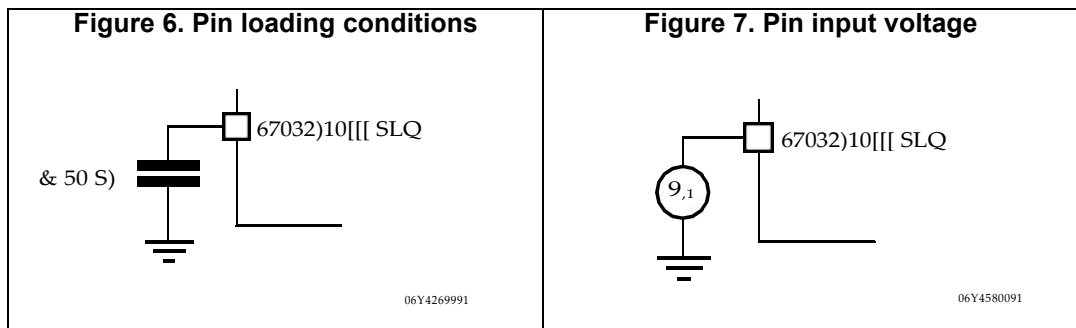
Unless otherwise specified, all typical curves are given only as design guidelines and are not tested.

#### 5.1.4 Loading capacitor

The loading conditions used for pin parameter measurement are shown in [Figure 6](#).

#### 5.1.5 Pin input voltage

The input voltage measurement on a pin of the device is described in [Figure 7](#).

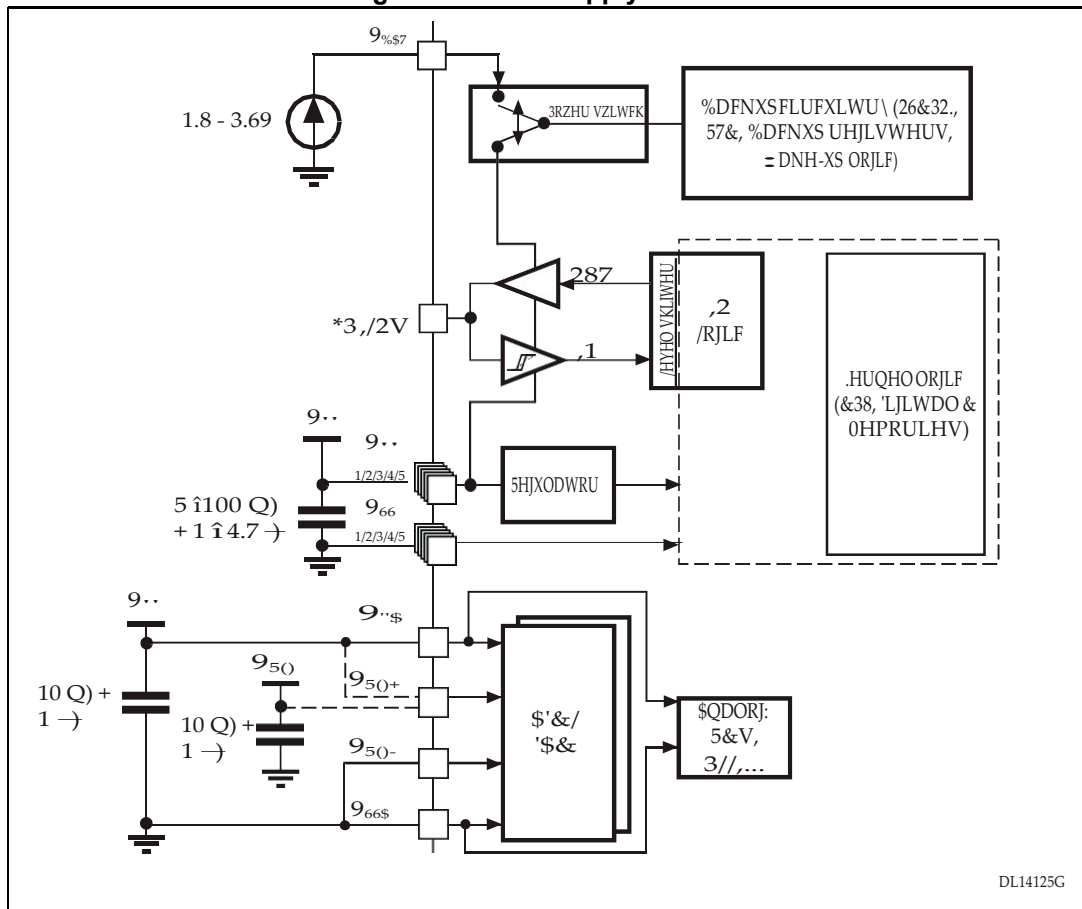






5.1.6 Power supply scheme

Figure 8. Power supply scheme

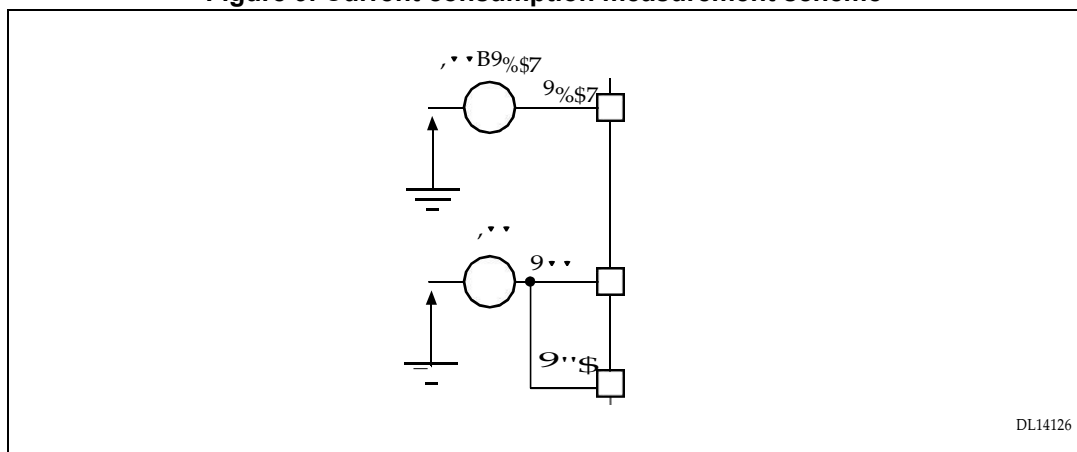


DL14125G

Caution: In Figure 8, the 4.7 µF capacitor must be connected to V<sub>DD3</sub>.

5.1.7 Current consumption measurement

Figure 9. Current consumption measurement scheme



DL14126



## 5.2 Absolute maximum ratings

Stresses above the absolute maximum ratings listed in [Table 6: Voltage characteristics](#), [Table 7: Current characteristics](#), and [Table 8: Thermal characteristics](#) may cause permanent damage to the device. These are stress ratings only and functional operation of the device at these conditions is not implied. Exposure to maximum rating conditions for extended periods may affect device reliability.

**Table 6. Voltage characteristics**

Symbol	Ratings	Min	Max	Unit
$V_{DD}-V_{SS}$	External main supply voltage (including $V_{DDA}$ and $V_{DD}$ ) <sup>(1)</sup>	-0.3	4.0	V
$V_{IN}^{(2)}$	Input voltage on five volt tolerant pin	$V_{SS}-0.3$	$V_{DD}+4.0$	
	Input voltage on any other pin	$V_{SS}-0.3$	4.0	
$ \Delta V_{DDx} $	Variations between different $V_{DD}$ power pins	-	50	mV
$ V_{SSx}-V_{SS} $	Variations between all the different ground pins	-	50	
$V_{ESD(HBM)}$	Electrostatic discharge voltage (human body model)	see <a href="#">Section 5.3.11: Absolute maximum ratings (electrical sensitivity)</a>		-

- All main power ( $V_{DD}$ ,  $V_{DDA}$ ) and ground ( $V_{SS}$ ,  $V_{SSA}$ ) pins must always be connected to the external power supply, in the permitted range.
- $V_{IN}$  maximum must always be respected. Refer to [Table 7: Current characteristics](#) for the maximum allowed injected current values.

**Table 7. Current characteristics**

Symbol	Ratings	Max.	Unit
$I_{VDD}$	Total current into $V_{DD}/V_{DDA}$ power lines (source) <sup>(1)</sup>	150	mA
$I_{VSS}$	Total current out of $V_{SS}$ ground lines (sink) <sup>(1)</sup>	150	
$I_{IO}$	Output current sunk by any I/O and control pin	25	
	Output current source by any I/Os and control pin	-25	
$I_{INJ(PIN)}^{(2)}$	Injected current on five volt tolerant pins <sup>(3)</sup>	-5/+0	
	Injected current on any other pin <sup>(4)</sup>	$\pm 5$	
$\Sigma I_{INJ(PIN)}$	Total injected current (sum of all I/O and control pins) <sup>(5)</sup>	$\pm 25$	

- All main power ( $V_{DD}$ ,  $V_{DDA}$ ) and ground ( $V_{SS}$ ,  $V_{SSA}$ ) pins must always be connected to the external power supply, in the permitted range.
- Negative injection disturbs the analog performance of the device. See [Note: on page 76](#).
- Positive injection is not possible on these I/Os. A negative injection is induced by  $V_{IN}<V_{SS}$ .  $I_{INJ(PIN)}$  must never be exceeded. Refer to [Table 6: Voltage characteristics](#) for the maximum allowed input voltage values.
- A positive injection is induced by  $V_{IN}>V_{DD}$  while a negative injection is induced by  $V_{IN}<V_{SS}$ .  $I_{INJ(PIN)}$  must never be exceeded. Refer to [Table 6: Voltage characteristics](#) for the maximum allowed input voltage values.
- When several inputs are submitted to a current injection, the maximum  $\Sigma I_{INJ(PIN)}$  is the absolute sum of the positive and negative injected currents (instantaneous values).



**Table 8. Thermal characteristics**

Symbol	Ratings	Value	Unit
T <sub>STG</sub>	Storage temperature range	-65 to +150	°C
T <sub>J</sub>	Maximum junction temperature	150	°C

### 5.3 Operating conditions

#### 5.3.1 General operating conditions

**Table 9. General operating conditions**

Symbol	Parameter	Conditions	Min	Max	Unit
f <sub>HCLK</sub>	Internal AHB clock frequency	-	0	72	MHz
f <sub>PCLK1</sub>	Internal APB1 clock frequency	-	0	36	
f <sub>PCLK2</sub>	Internal APB2 clock frequency	-	0	72	
V <sub>DD</sub>	Standard operating voltage	-	2	3.6	V
V <sub>DDA</sub> <sup>(1)</sup>	Analog operating voltage (ADC not used)	Must be the same potential as V <sub>DD</sub> <sup>(2)</sup>	2	3.6	V
	Analog operating voltage (ADC used)		2.4	3.6	
V <sub>BAT</sub>	Backup operating voltage	-	1.8	3.6	V
P <sub>D</sub>	Power dissipation at T <sub>A</sub> = 85 °C for suffix 6 or T <sub>A</sub> = 105 °C for suffix 7 <sup>(3)</sup>	LFBGA100	-	500	mW
		LQFP100	-	434	
		LQFP64	-	444	
P <sub>D</sub>	Power dissipation at T <sub>A</sub> = 85 °C for suffix 6 or T <sub>A</sub> = 105 °C for suffix 7 <sup>(4)</sup>	LQFP100	-	434	mW
		LQFP64	-	444	
T <sub>A</sub>	Ambient temperature for 6 suffix version	Maximum power dissipation	-40	85	°C
		Low power dissipation <sup>(5)</sup>	-40	105	
	Ambient temperature for 7 suffix version	Maximum power dissipation	-40	105	°C
		Low power dissipation <sup>(5)</sup>	-40	125	
T <sub>J</sub>	Junction temperature range	6 suffix version	-40	105	°C
		7 suffix version	-40	125	

1. When the ADC is used, refer to [Table 52: ADC characteristics](#).
2. It is recommended to power V<sub>DD</sub> and V<sub>DDA</sub> from the same source. A maximum difference of 300 mV between V<sub>DD</sub> and V<sub>DDA</sub> can be tolerated during power-up and operation.
3. If T<sub>A</sub> is lower, higher P<sub>D</sub> values are allowed as long as T<sub>J</sub> does not exceed T<sub>Jmax</sub>.
4. If T<sub>A</sub> is lower, higher P<sub>D</sub> values are allowed as long as T<sub>J</sub> does not exceed T<sub>Jmax</sub>.
5. In low power dissipation state, T<sub>A</sub> can be extended to this range as long as T<sub>J</sub> does not exceed T<sub>Jmax</sub>.



### 5.3.2 Operating conditions at power-up / power-down

Subject to general operating conditions for T<sub>A</sub>.

**Table 10. Operating condition at power-up / power down**

Symbol	Parameter	Condition	Min	Max	Unit
t <sub>VDD</sub>	V <sub>DD</sub> rise time rate	-	0	-	μs/V
T <sub>J</sub>	V <sub>DD</sub> fall time rate		20	-	

### 5.3.3 Embedded reset and power control block characteristics

The parameters given in [Table 11](#) are derived from tests performed under ambient temperature and V<sub>DD</sub> supply voltage conditions summarized in [Table 9](#).

**Table 11. Embedded reset and power control block characteristics**

Symbol	Parameter	Conditions	Min	Typ	Max	Unit
V <sub>PVD</sub>	Programmable voltage detector level selection	PLS[2:0]=000 (rising edge)	2.1	2.18	2.26	V
		PLS[2:0]=000 (falling edge)	2	2.08	2.16	V
		PLS[2:0]=001 (rising edge)	2.19	2.28	2.37	V
		PLS[2:0]=001 (falling edge)	2.09	2.18	2.27	V
		PLS[2:0]=010 (rising edge)	2.28	2.38	2.48	V
		PLS[2:0]=010 (falling edge)	2.18	2.28	2.38	V
		PLS[2:0]=011 (rising edge)	2.38	2.48	2.58	V
		PLS[2:0]=011 (falling edge)	2.28	2.38	2.48	V
		PLS[2:0]=100 (rising edge)	2.47	2.58	2.69	V
		PLS[2:0]=100 (falling edge)	2.37	2.48	2.59	V
		PLS[2:0]=101 (rising edge)	2.57	2.68	2.79	V
		PLS[2:0]=101 (falling edge)	2.47	2.58	2.69	V
		PLS[2:0]=110 (rising edge)	2.66	2.78	2.9	V
		PLS[2:0]=110 (falling edge)	2.56	2.68	2.8	V
PLS[2:0]=111 (rising edge)	2.76	2.88	3	V		
PLS[2:0]=111 (falling edge)	2.66	2.78	2.9	V		
V <sub>PVDhyst</sub> <sup>(2)</sup>	PVD hysteresis	-	-	100	-	mV
V <sub>POR/PDR</sub>	Power on/power down reset threshold	Falling edge	1.8 <sup>(1)</sup>	1.88	1.96	V
		Rising edge	1.84	1.92	2.0	V
V <sub>PDRhyst</sub> <sup>(2)</sup>	PDR hysteresis	-	-	40	-	mV
T <sub>RSTTEMPO</sub> <sup>(2)</sup>	Reset temporization	-	1	2.5	4.5	ms

1. The product behavior is guaranteed by design down to the minimum V<sub>POR/PDR</sub> value.

2. Guaranteed by design, not tested in production.





### 5.3.4 Embedded reference voltage

The parameters given in [Table 12](#) are derived from tests performed under ambient temperature and  $V_{DD}$  supply voltage conditions summarized in [Table 9](#).

**Table 12. Embedded internal reference voltage**

Symbol	Parameter	Conditions	Min	Typ	Max	Unit
$V_{REFINT}$	Internal reference voltage	$-40\text{ }^{\circ}\text{C} < T_A < +105\text{ }^{\circ}\text{C}$	1.16	1.20	1.26	V
		$-40\text{ }^{\circ}\text{C} < T_A < +85\text{ }^{\circ}\text{C}$	1.16	1.20	1.24	V
$T_{S\_vrefint}^{(1)}$	ADC sampling time when reading the internal reference voltage	-	-	5.1	17.1 <sup>(2)</sup>	$\mu\text{s}$
$V_{RERINT}^{(2)}$	Internal reference voltage spread over the temperature range	$V_{DD} = 3\text{ V} \pm 10\text{ mV}$	-	-	10	mV
$T_{Coeff}^{(2)}$	Temperature coefficient	-	-	-	100	ppm/ $^{\circ}\text{C}$

1. Shortest sampling time can be determined in the application by multiple iterations.
2. Guaranteed by design, not tested in production.

### 5.3.5 Supply current characteristics

The current consumption is a function of several parameters and factors such as the operating voltage, ambient temperature, I/O pin loading, device software configuration, operating frequencies, I/O pin switching rate, program location in memory and executed binary code.

The current consumption is measured as described in [Figure 9: Current consumption measurement scheme](#).

All Run-mode current consumption measurements given in this section are performed with a reduced code that gives a consumption equivalent to Dhrystone 2.1 code.

#### Maximum current consumption

The MCU is placed under the following conditions:

- All I/O pins are in input mode with a static value at  $V_{DD}$  or  $V_{SS}$  (no load)
- All peripherals are disabled except when explicitly mentioned
- The Flash memory access time is adjusted to the  $f_{HCLK}$  frequency (0 wait state from 0 to 24 MHz, 1 wait state from 24 to 48 MHz and 2 wait states above)
- Prefetch in ON (reminder: this bit must be set before clock setting and bus prescaling)
- When the peripherals are enabled  $f_{PCLK1} = f_{HCLK}/2$ ,  $f_{PCLK2} = f_{HCLK}$

The parameters given in [Table 13](#), [Table 14](#) and [Table 15](#) are derived from tests performed under ambient temperature and  $V_{DD}$  supply voltage conditions summarized in [Table 9](#).



**Table 13. Maximum current consumption in Run mode, code with data processing running from Flash**

Symbol	Parameter	Conditions	f <sub>HCLK</sub>	Max <sup>(1)</sup>		Unit
				T <sub>A</sub> = 85 °C	T <sub>A</sub> = 105 °C	
I <sub>DD</sub>	Supply current in Run mode	External clock <sup>(2)</sup> , all peripherals enabled	72 MHz	68	68.4	mA
			48 MHz	49	49.2	
			36 MHz	38.7	38.9	
			24 MHz	27.3	27.9	
			16 MHz	20.2	20.5	
			8 MHz	10.2	10.8	
		External clock <sup>(2)</sup> , all peripherals disabled	72 MHz	32.7	32.9	
			48 MHz	25	25.2	
			36 MHz	20.3	20.6	
			24 MHz	14.8	15.1	
			16 MHz	11.2	11.7	
			8 MHz	6.6	7.2	

1. Based on characterization, not tested in production.
2. External clock is 8 MHz and PLL is on when f<sub>HCLK</sub> > 8 MHz.

**Table 14. Maximum current consumption in Run mode, code with data processing running from RAM**

Symbol	Parameter	Conditions	f <sub>HCLK</sub>	Max <sup>(1)</sup>		Unit
				T <sub>A</sub> = 85 °C	T <sub>A</sub> = 105 °C	
I <sub>DD</sub>	Supply current in Run mode	External clock <sup>(2)</sup> , all peripherals enabled	72 MHz	65.5	66	mA
			48 MHz	45.4	46	
			36 MHz	35.5	36.1	
			24 MHz	25.2	25.6	
			16 MHz	18	18.5	
			8 MHz	10.5	11	
		External clock <sup>(2)</sup> , all peripherals disabled	72 MHz	31.4	31.9	
			48 MHz	27.8	28.2	
			36 MHz	17.6	18.3	
			24 MHz	13.1	13.8	
			16 MHz	10.2	10.9	
			8 MHz	6.1	7.8	

1. Based on characterization, tested in production at V<sub>DD</sub> max, f<sub>HCLK</sub> max..
2. External clock is 8 MHz and PLL is on when f<sub>HCLK</sub> > 8 MHz.



**Table 15. Maximum current consumption in Sleep mode, code running from Flash or RAM**

Symbol	Parameter	Conditions	f <sub>HCLK</sub>	Max <sup>(1)</sup>		Unit
				T <sub>A</sub> = 85 °C	T <sub>A</sub> = 105 °C	
I <sub>DD</sub>	Supply current in Sleep mode	External clock <sup>(2)</sup> , all peripherals enabled	72 MHz	48.4	49	mA
			48 MHz	33.9	34.4	
			36 MHz	26.7	27.2	
			24 MHz	19.3	19.8	
			16 MHz	14.2	14.8	
			8 MHz	8.7	9.1	
		External clock <sup>(2)</sup> , all peripherals disabled	72 MHz	10.1	10.6	
			48 MHz	8.3	8.75	
			36 MHz	7.5	8	
			24 MHz	6.6	7.1	
			16 MHz	6	6.5	
			8 MHz	2.5	3	

1. Based on characterization, tested in production at V<sub>DD</sub> max and f<sub>HCLK</sub> max with peripherals enabled.
2. External clock is 8 MHz and PLL is on when f<sub>HCLK</sub> > 8 MHz.

**Table 16. Typical and maximum current consumptions in Stop and Standby modes**

Symbol	Parameter	Conditions	Typ <sup>(1)</sup>			Max		Unit
			V <sub>DD</sub> /V <sub>BAT</sub> = 2.0 V	V <sub>DD</sub> /V <sub>BAT</sub> = 2.4 V	V <sub>DD</sub> /V <sub>BAT</sub> = 3.3 V	T <sub>A</sub> = 85 °C	T <sub>A</sub> = 105 °C	
I <sub>DD</sub>	Supply current in Stop mode	Regulator in Run mode, low-speed and high-speed internal RC oscillators and high-speed oscillator OFF (no independent watchdog)	-	32	33	600	1300	µA
		Regulator in Low Power mode, low-speed and high-speed internal RC oscillators and high-speed oscillator OFF (no independent watchdog)	-	25	26	590	1280	
	Supply current in Standby mode	Low-speed internal RC oscillator and independent watchdog ON	-	3	3.8	-	-	
		Low-speed internal RC oscillator ON, independent watchdog OFF	-	2.8	3.6	-	-	
		Low-speed internal RC oscillator and independent watchdog OFF, low-speed oscillator and RTC OFF	-	1.9	2.1	5 <sup>(2)</sup>	6.5 <sup>(2)</sup>	
I <sub>DD_VBAT</sub>	Backup domain supply current	Low-speed oscillator and RTC ON	1.1	1.2	1.4	2.1 <sup>(2)</sup>	2.3 <sup>(2)</sup>	

1. Typical values are measured at T<sub>A</sub> = 25 °C.
2. Based on characterization, not tested in production.



Figure 10. Typical current consumption on V<sub>BAT</sub> with RTC on vs. temperature at different V<sub>BAT</sub> values

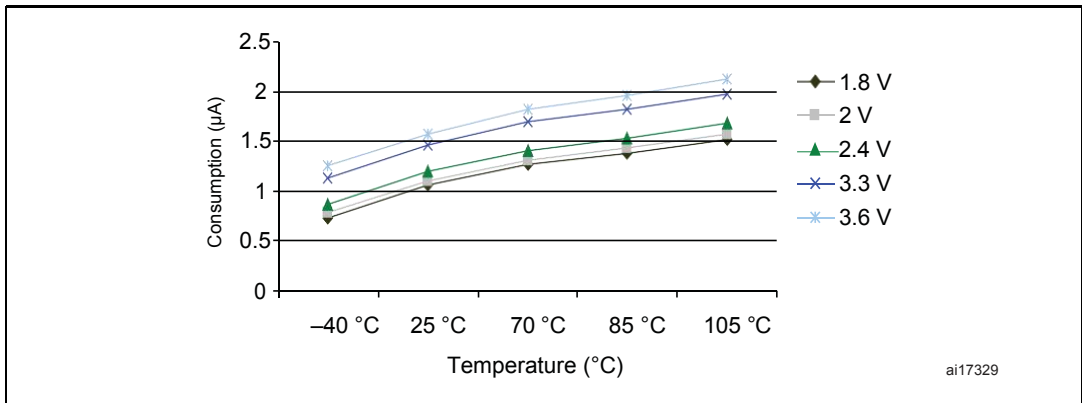
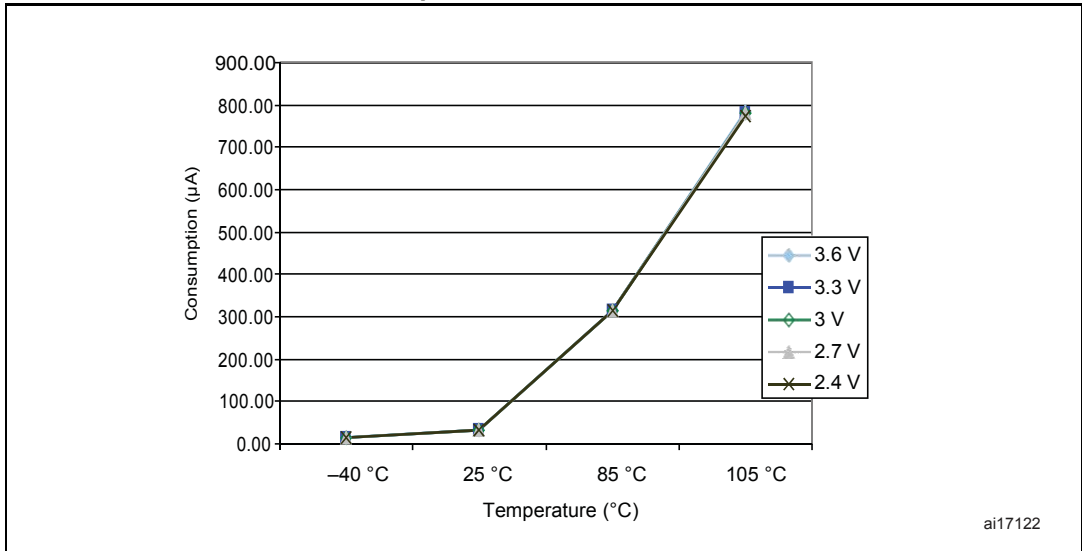


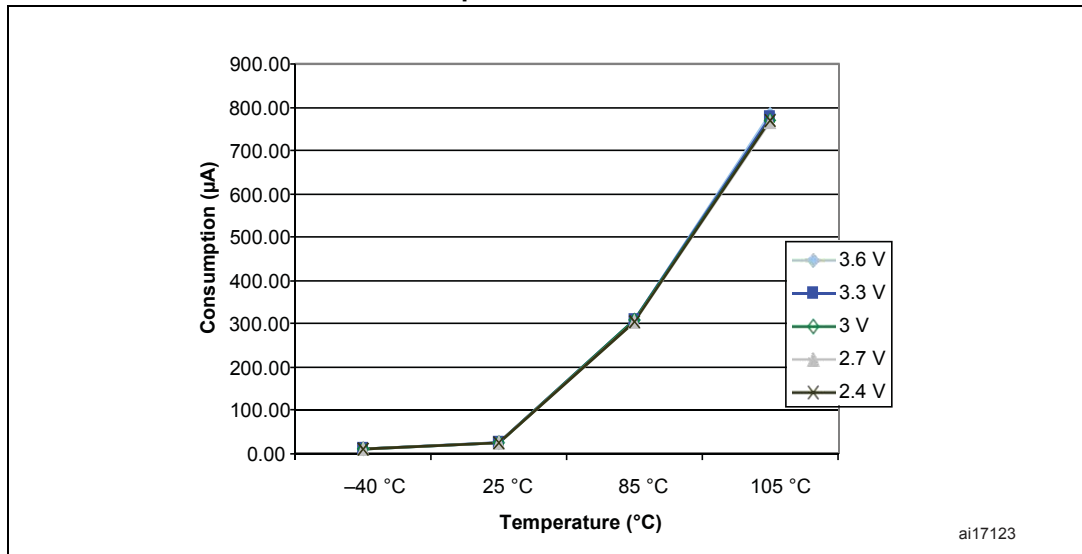
Figure 11. Typical current consumption in Stop mode with regulator in Run mode versus temperature at different V<sub>DD</sub> values



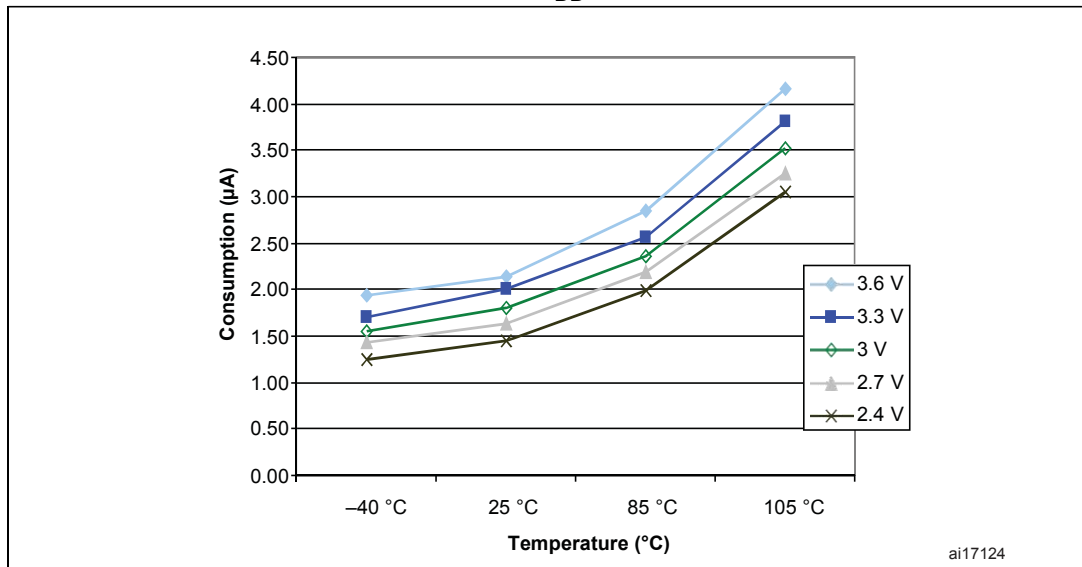




**Figure 12. Typical current consumption in Stop mode with regulator in Low-power mode versus temperature at different V<sub>DD</sub> values**



**Figure 13. Typical current consumption in Standby mode versus temperature at different V<sub>DD</sub> values**



**Typical current consumption**

The MCU is placed under the following conditions:

- All I/O pins are in input mode with a static value at V<sub>DD</sub> or V<sub>SS</sub> (no load).
- All peripherals are disabled except if it is explicitly mentioned.
- The Flash access time is adjusted to f<sub>HCLK</sub> frequency (0 wait state from 0 to 24 MHz, 1 wait state from 24 to 48 MHz and 2 wait states above).
- Ambient temperature and V<sub>DD</sub> supply voltage conditions summarized in [Table 9](#).
- Prefetch is ON (Reminder: this bit must be set before clock setting and bus prescaling)

When the peripherals are enabled f<sub>PCLK1</sub> = f<sub>HCLK</sub>/4, f<sub>PCLK2</sub> = f<sub>HCLK</sub>/2, f<sub>ADCCLK</sub> = f<sub>PCLK2</sub>/4



**Table 17. Typical current consumption in Run mode, code with data processing running from Flash**

Symbol	Parameter	Conditions	f <sub>HCLK</sub>	Typ <sup>(1)</sup>		Unit
				All peripherals enabled <sup>(2)</sup>	All peripherals disabled	
I <sub>DD</sub>	Supply current in Run mode	External clock <sup>(3)</sup>	72 MHz	47.3	28.3	mA
			48 MHz	32	19.6	
			36 MHz	24.6	15.4	
			24 MHz	16.8	10.6	
			16 MHz	11.8	7.4	
			8 MHz	5.9	3.7	
			4 MHz	3.7	2.9	
			2 MHz	2.5	2	
			1 MHz	1.8	1.53	
			500 kHz	1.5	1.3	
		125 kHz	1.3	1.2		
		Running on high speed internal RC (HSI), AHB prescaler used to reduce the frequency	36 MHz	23.9	14.8	mA
			24 MHz	16.1	9.7	
			16 MHz	11.1	6.7	
			8 MHz	5.6	3.8	
			4 MHz	3.1	2.1	
			2 MHz	1.8	1.3	
			1 MHz	1.16	0.9	
			500 kHz	0.8	0.67	
125 kHz	0.6	0.5				

1. Typical values are measures at T<sub>A</sub> = 25 °C, V<sub>DD</sub> = 3.3V.
2. Add an additional power consumption of 0.8 mA per ADC for the analog part. In applications, this consumption occurs only while the ADC is on (ADON bit is set in the ADC\_CR2 register).
3. External clock is 8 MHz and PLL is on when f<sub>HCLK</sub> > 8 MHz.



**Table 18. Typical current consumption in Sleep mode, code running from Flash or RAM**

Symbol	Parameter	Conditions	f <sub>HCLK</sub>	Typ <sup>(1)</sup>		Unit
				All peripherals enabled <sup>(2)</sup>	All peripherals disabled	
I <sub>DD</sub>	Supply current in Sleep mode	External clock <sup>(3)</sup>	72 MHz	28.2	6	mA
			48 MHz	19	4.2	
			36 MHz	14.7	3.4	
			24 MHz	10.1	2.5	
			16 MHz	6.7	2	
			8 MHz	3.2	1.3	
			4 MHz	2.3	1.2	
			2 MHz	1.7	1.16	
			1 MHz	1.5	1.1	
			500 kHz	1.3	1.05	
		125 kHz	1.2	1.05		
		Running on high speed internal RC (HSI), AHB prescaler used to reduce the frequency	36 MHz	13.7	2.6	
			24 MHz	9.3	1.8	
			16 MHz	6.3	1.3	
			8 MHz	2.7	0.6	
			4 MHz	1.6	0.5	
			2 MHz	1	0.46	
			1 MHz	0.8	0.44	
			500 kHz	0.6	0.43	
		125 kHz	0.5	0.42		

1. Typical values are measures at T<sub>A</sub> = 25 °C, V<sub>DD</sub> = 3.3 V.
2. Add an additional power consumption of 0.8 mA per ADC for the analog part. In applications, this consumption occurs only while the ADC is on (ADON bit is set in the ADC\_CR2 register).
3. External clock is 8 MHz and PLL is on when f<sub>HCLK</sub> > 8 MHz.

**On-chip peripheral current consumption**

The current consumption of the on-chip peripherals is given in [Table 19](#). The MCU is placed under the following conditions:

- all I/O pins are in input mode with a static value at V<sub>DD</sub> or V<sub>SS</sub> (no load)
- all peripherals are disabled unless otherwise mentioned
- the given value is calculated by measuring the current consumption
  - with all peripherals clocked off
  - with one peripheral clocked on (with only the clock applied)
- ambient operating temperature and V<sub>DD</sub> supply voltage conditions summarized in [Table 6](#)





Table 19. Peripheral current consumption

Peripheral		Typical consumption at 25 °C	Unit
AHB (up to 72 MHz)	DMA1	14.03	μA/MHz
	DMA2	9.31	
	OTG_fs	111.11	
	ETH-MAC	56.25	
	CRC	1.11	
	BusMatrix <sup>(1)</sup>	15.97	
APB1(up to 36MHz)	APB1-Bridge	9.72	μA/MHz
	TIM2	33.61	
	TIM3	33.06	
	TIM4	32.50	
	TIM5	31.94	
	TIM6	6.11	
	TIM7	6.11	
	SPI2/I2S2 <sup>(2)</sup>	7.50	
	SPI3/I2S3 <sup>(2)</sup>	7.50	
	USART2	10.83	
	USART3	11.11	
	UART4	10.83	
	UART5	10.56	
	I2C1	11.39	
	I2C2	11.11	
	CAN1	19.44	
	CAN2	18.33	
	DAC <sup>(3)</sup>	8.61	
	WWDG	3.33	
	PWR	2.22	
BKP	0.83		
IWDG	3.89		





**Table 19. Peripheral current consumption (continued)**

Peripheral		Typical consumption at 25 °C	Unit
APB2 (up to 72 MHz)	APB2-Bridge	3.47	µA/MHz
	GPIOA	6.39	
	GPIOB	6.39	
	GPIOC	6.11	
	GPIOD	6.39	
	GPIOE	6.11	
	SPI1	3.61	
	USART1	12.08	
	TIM1	23.47	
	ADC1 <sup>(4)</sup>	18.21	

1. The BusMatrix is automatically active when at least one master is ON.(CPU, ETH-MAC, DMA1 or DMA2).
2. When I2S is enabled we have a consumption add equal to 0, 02 mA.
3. When DAC\_OUT1 or DAC\_OUT2 is enabled we have a consumption add equal to 0, 3 mA.
4. Specific conditions for measuring ADC current consumption:  $f_{HCLK} = 56 \text{ MHz}$ ,  $f_{APB1} = f_{HCLK}/2$ ,  $f_{APB2} = f_{HCLK}$ ,  $f_{ADCCLK} = f_{APB2}/4$ . When ADON bit in the ADC\_CR2 register is set to 1, a current consumption of analog part equal to 0.6 mA must be added.

### 5.3.6 External clock source characteristics

#### High-speed external user clock generated from an external source

The characteristics given in [Table 20](#) result from tests performed using an high-speed external clock source, and under ambient temperature and supply voltage conditions summarized in [Table 9](#).

**Table 20. High-speed external user clock characteristics**

Symbol	Parameter	Conditions	Min	Typ	Max	Unit
$f_{HSE\_ext}$	External user clock source frequency <sup>(1)</sup>		1	8	50	MHz
$V_{HSEH}$	OSC_IN input pin high level voltage	-	0.7V <sub>DD</sub>	-	V <sub>DD</sub>	V
$V_{HSEL}$	OSC_IN input pin low level voltage		V <sub>SS</sub>	-	0.3V <sub>DD</sub>	
$t_{w(HSE)}$ $t_{w(HSE)}$	OSC_IN high or low time <sup>(1)</sup>		5	-	-	ns
$t_{r(HSE)}$ $t_{f(HSE)}$	OSC_IN rise or fall time <sup>(1)</sup>	-	-	20		
$C_{in(HSE)}$	OSC_IN input capacitance <sup>(1)</sup>	-	-	5	-	pF
DuCy <sub>(HSE)</sub>	Duty cycle	-	45	-	55	%
$I_L$	OSC_IN Input leakage current	$V_{SS} \leq V_{IN} \leq V_{DD}$	-	-	±1	µA

1. Guaranteed by design, not tested in production.



**Low-speed external user clock generated from an external source**

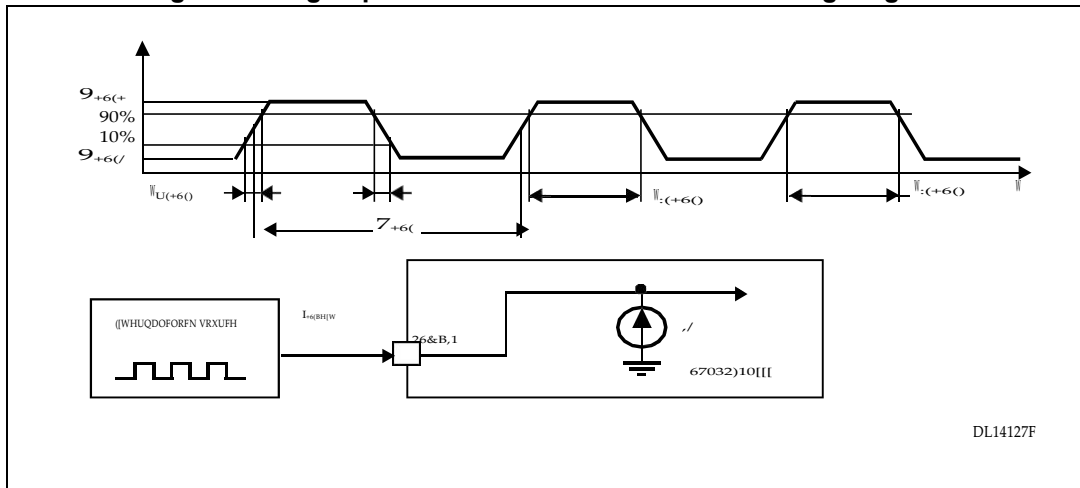
The characteristics given in *Table 21* result from tests performed using an low-speed external clock source, and under ambient temperature and supply voltage conditions summarized in *Table 9*.

**Table 21. Low-speed external user clock characteristics**

Symbol	Parameter	Conditions	Min	Typ	Max	Unit
$f_{LSE\_ext}$	User External clock source frequency <sup>(1)</sup>			32.768	1000	kHz
$V_{LSEH}$	OSC32_IN input pin high level voltage		$0.7V_{DD}$	-	$V_{DD}$	V
$V_{LSEL}$	OSC32_IN input pin low level voltage	-	$V_{SS}$	-	$0.3V_{DD}$	
$t_{w(LSE)}$ $t_{w(LSE)}$	OSC32_IN high or low time <sup>(1)</sup>		450	-	-	ns
$t_{r(LSE)}$ $t_{f(LSE)}$	OSC32_IN rise or fall time <sup>(1)</sup>		-	-	50	
$C_{in(LSE)}$	OSC32_IN input capacitance <sup>(1)</sup>	-	-	5		pF
DuCy(LSE)	Duty cycle	-	30	-	70	%
$I_L$	OSC32_IN Input leakage current	$V_{SS} \leq V_{IN} \leq V_{DD}$	-	-	$\pm 1$	$\mu A$

1. Guaranteed by design, not tested in production.

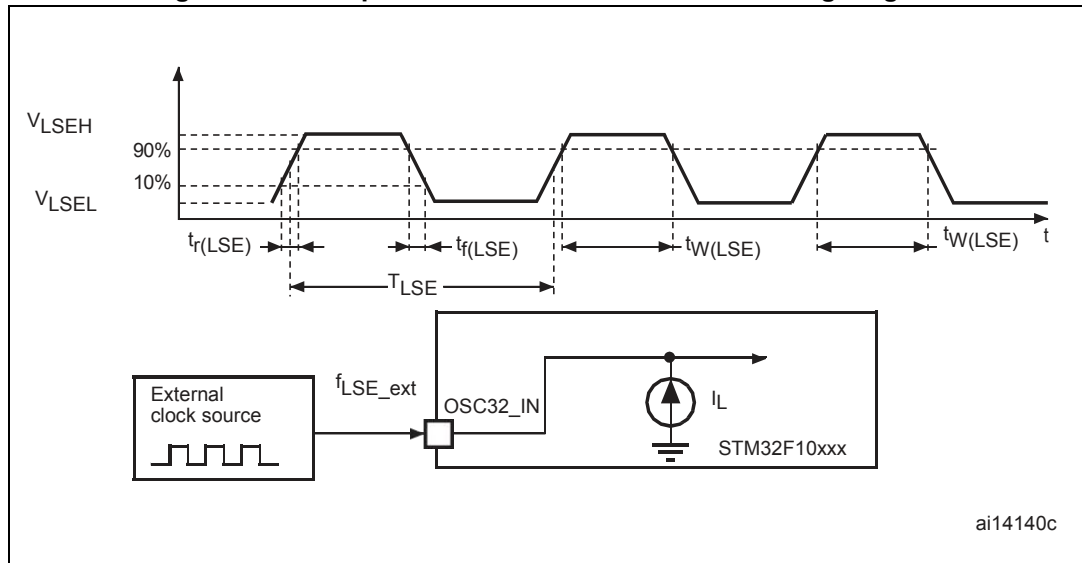
**Figure 14. High-speed external clock source AC timing diagram**



DL14127F



Figure 15. Low-speed external clock source AC timing diagram



**High-speed external clock generated from a crystal/ceramic resonator**

The high-speed external (HSE) clock can be supplied with a 3 to 25 MHz crystal/ceramic resonator oscillator. All the information given in this paragraph are based on characterization results obtained with typical external components specified in Table 22. In the application, the resonator and the load capacitors have to be placed as close as possible to the oscillator pins in order to minimize output distortion and startup stabilization time. Refer to the crystal resonator manufacturer for more details on the resonator characteristics (frequency, package, accuracy).

Table 22. HSE 3-25 MHz oscillator characteristics<sup>(1) (2)</sup>

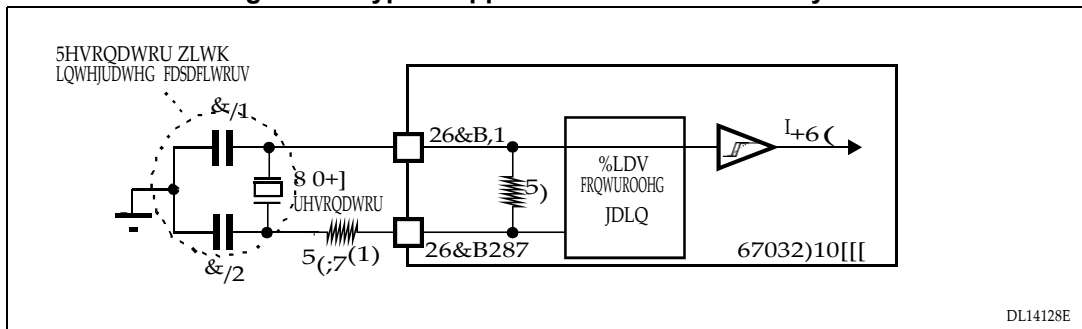
Symbol	Parameter	Conditions	Min	Typ	Max	Unit
f <sub>OSC_IN</sub>	Oscillator frequency	-	3		25	MHz
R <sub>F</sub>	Feedback resistor	-	-	200	-	k Ω
C	Recommended load capacitance versus equivalent serial resistance of the crystal (R <sub>S</sub> ) <sup>(3)</sup>	R <sub>S</sub> = 30 Ω	-	30	-	pF
i <sub>2</sub>	HSE driving current	V <sub>DD</sub> = 3.3 V, V <sub>IN</sub> = V <sub>SS</sub> with 30 pF load	-	-	1	mA
g <sub>m</sub>	Oscillator transconductance	Startup	25	-	-	mA/V
t <sub>SU(HSE)</sub> <sup>(4)</sup>	Startup time	V <sub>DD</sub> is stabilized	-	2	-	ms

1. Resonator characteristics given by the crystal/ceramic resonator manufacturer.
2. Based on characterization, not tested in production.
3. The relatively low value of the R<sub>F</sub> resistor offers a good protection against issues resulting from use in a humid environment, due to the induced leakage and the bias condition change. However, it is recommended to take this point into account if the MCU is used in tough humidity conditions.
4. t<sub>SU(HSE)</sub> is the startup time measured from the moment it is enabled (by software) to a stabilized 8 MHz oscillation is reached. This value is measured for a standard crystal resonator and it can vary significantly with the crystal manufacturer



For  $C_{L1}$  and  $C_{L2}$ , it is recommended to use high-quality external ceramic capacitors in the 5 pF to 25 pF range (typ.), designed for high-frequency applications, and selected to match the requirements of the crystal or resonator (see [Figure 16](#)).  $C_{L1}$  and  $C_{L2}$  are usually the same size. The crystal manufacturer typically specifies a load capacitance which is the series combination of  $C_{L1}$  and  $C_{L2}$ . PCB and MCU pin capacitance must be included (10 pF can be used as a rough estimate of the combined pin and board capacitance) when sizing  $C_{L1}$  and  $C_{L2}$ . Refer to the application note AN2867 “Oscillator design guide for ST microcontrollers” available from the ST website [www.st.com](http://www.st.com).

Figure 16. Typical application with an 8 MHz crystal



1.  $R_{EXT}$  value depends on the crystal characteristics.

### Low-speed external clock generated from a crystal/ceramic resonator

The low-speed external (LSE) clock can be supplied with a 32.768 kHz crystal/ceramic resonator oscillator. All the information given in this paragraph are based on characterization results obtained with typical external components specified in [Table 23](#). In the application, the resonator and the load capacitors have to be placed as close as possible to the oscillator pins in order to minimize output distortion and startup stabilization time. Refer to the crystal resonator manufacturer for more details on the resonator characteristics (frequency, package, accuracy).

Table 23. LSE oscillator characteristics ( $f_{LSE} = 32.768$  kHz) <sup>(1)</sup>

Symbol	Parameter	Conditions	Min	Typ	Max	Unit
$R_F$	Feedback resistor	-	-	5	-	$M\Omega$
$C^{(2)}$	Recommended load capacitance versus equivalent serial resistance of the crystal ( $R_S$ ) <sup>(3)</sup>	$R_S = 30\text{ k}\Omega$	-	-	15	pF
$I_2$	LSE driving current	$V_{DD} = 3.3\text{ V}, V_{IN} = V_{SS}$	-	-	1.4	$\mu\text{A}$
$g_m$	Oscillator Transconductance	-	5	-	-	$\mu\text{A/V}$





**Table 23. LSE oscillator characteristics (f<sub>LSE</sub> = 32.768 kHz) <sup>(1)</sup> (continued)**

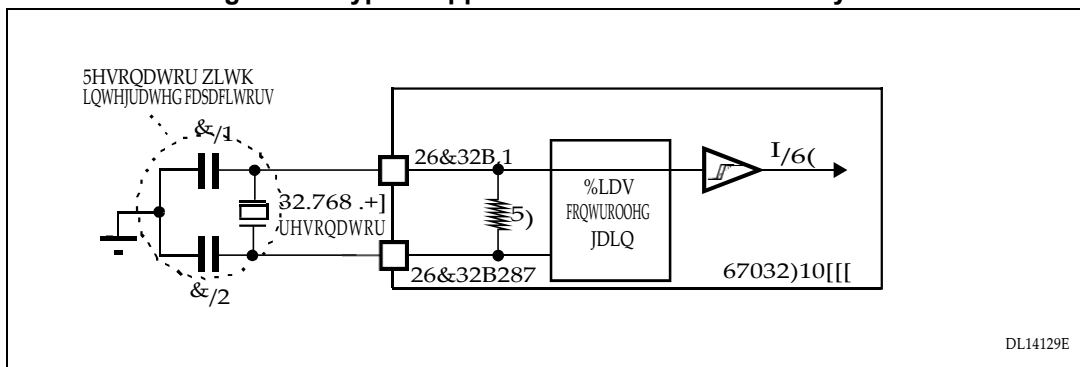
Symbol	Parameter	Conditions	Min	Typ	Max	Unit	
t <sub>SU(LSE)</sub> (4)	Startup time	V <sub>DD</sub> is stabilized	T <sub>A</sub> = 50 °C	-	1.5	-	s
			T <sub>A</sub> = 25 °C	-	2.5	-	
			T <sub>A</sub> = 10 °C	-	4	-	
			T <sub>A</sub> = 0 °C	-	6	-	
			T <sub>A</sub> = -10 °C	-	10	-	
			T <sub>A</sub> = -20 °C	-	17	-	
			T <sub>A</sub> = -30 °C	-	32	-	
			T <sub>A</sub> = -40 °C	-	60	-	

1. Based on characterization, not tested in production.
2. Refer to the note and caution paragraphs below the table, and to the application note AN2867 "Oscillator design guide for ST microcontrollers".
3. The oscillator selection can be optimized in terms of supply current using an high quality resonator with small R<sub>s</sub> value for example MSIV-TIN32.768kHz. Refer to crystal manufacturer for more details
4. t<sub>SU(LSE)</sub> is the startup time measured from the moment it is enabled (by software) to a stabilized 32.768 kHz oscillation is reached. This value is measured for a standard crystal and it can vary significantly with the crystal manufacturer

**Note:** For C<sub>L1</sub> and C<sub>L2</sub> it is recommended to use high-quality external ceramic capacitors in the 5 pF to 15 pF range selected to match the requirements of the crystal or resonator (see Figure 17). C<sub>L1</sub> and C<sub>L2</sub> are usually the same size. The crystal manufacturer typically specifies a load capacitance which is the series combination of C<sub>L1</sub> and C<sub>L2</sub>. Load capacitance C<sub>L</sub> has the following formula:  $C_L = C_{L1} \times C_{L2} / (C_{L1} + C_{L2}) + C_{stray}$  where C<sub>stray</sub> is the pin capacitance and board or trace PCB-related capacitance. Typically, it is between 2 pF and 7 pF.

**Caution:** To avoid exceeding the maximum value of C<sub>L1</sub> and C<sub>L2</sub> (15 pF) it is strongly recommended to use a resonator with a load capacitance C<sub>L</sub> ≤ 7 pF. Never use a resonator with a load capacitance of 12.5 pF.  
**Example:** if you choose a resonator with a load capacitance of C<sub>L</sub> = 6 pF, and C<sub>stray</sub> = 2 pF, then C<sub>L1</sub> = C<sub>L2</sub> = 8 pF.

**Figure 17. Typical application with a 32.768 kHz crystal**



### 5.3.7 Internal clock source characteristics

The parameters given in [Table 24](#) are derived from tests performed under ambient temperature and  $V_{DD}$  supply voltage conditions summarized in [Table 9](#).

#### High-speed internal (HSI) RC oscillator

**Table 24. HSI oscillator characteristics** <sup>(1)</sup>

Symbol	Parameter	Conditions	Min	Typ	Max	Unit	
$f_{HSI}$	Frequency	-	-	8		MHz	
$DuCy_{(HSI)}$	Duty cycle	-	45	-	55	%	
$ACC_{HSI}$	Accuracy of the HSI oscillator	User-trimmed with the RCC_CR register <sup>(2)</sup>	-	-	1 <sup>(3)</sup>	%	
		Factory-calibrated <sup>(4)</sup>	$T_A = -40$ to $105$ °C	-2	-	2.5	%
			$T_A = -10$ to $85$ °C	-1.5	-	2.2	%
			$T_A = 0$ to $70$ °C	-1.3	-	2	%
	$T_A = 25$ °C	-1.1	-	1.8	%		
$t_{su(HSI)}^{(4)}$	HSI oscillator startup time	-	1	-	2	μs	
$I_{DD(HSI)}^{(4)}$	HSI oscillator power consumption	-	-	80	100	μA	

1.  $V_{DD} = 3.3$  V,  $T_A = -40$  to  $105$  °C unless otherwise specified.

2. Refer to application note AN2868 "STM32F10xxx internal RC oscillator (HSI) calibration" available from the ST website [www.st.com](http://www.st.com).

3. Guaranteed by design, not tested in production.

4. Based on characterization, not tested in production.

#### Low-speed internal (LSI) RC oscillator

**Table 25. LSI oscillator characteristics** <sup>(1)</sup>

Symbol	Parameter	Min	Typ	Max	Unit
$f_{LSI}^{(2)}$	Frequency	30	40	60	kHz
$t_{su(LSI)}^{(3)}$	LSI oscillator startup time	-	-	85	μs
$I_{DD(LSI)}^{(3)}$	LSI oscillator power consumption	-	0.65	1.2	μA

1.  $V_{DD} = 3$  V,  $T_A = -40$  to  $105$  °C unless otherwise specified.

2. Based on characterization, not tested in production.

3. Guaranteed by design, not tested in production.

#### Wakeup time from low-power mode

The wakeup times given in [Table 26](#) is measured on a wakeup phase with a 8-MHz HSI RC oscillator. The clock source used to wake up the device depends from the current operating mode:

- Stop or Standby mode: the clock source is the RC oscillator
- Sleep mode: the clock source is the clock that was set before entering Sleep mode.



All timings are derived from tests performed under ambient temperature and V<sub>DD</sub> supply voltage conditions summarized in [Table 9](#).

**Table 26. Low-power mode wakeup timings**

Symbol	Parameter	Typ	Unit
t <sub>WUSLEEP</sub> <sup>(1)</sup>	Wakeup from Sleep mode	1.8	µs
t <sub>WUSTO<sub>P</sub></sub> <sup>(1)</sup>	Wakeup from Stop mode (regulator in run mode)	3.6	µs
	Wakeup from Stop mode (regulator in low power mode)	5.4	
t <sub>WUSTDBY</sub> <sup>(1)</sup>	Wakeup from Standby mode	50	µs

1. The wakeup times are measured from the wakeup event to the point in which the user application code reads the first instruction.

### 5.3.8 PLL, PLL2 and PLL3 characteristics

The parameters given in [Table 27](#) and [Table 28](#) are derived from tests performed under temperature and V<sub>DD</sub> supply voltage conditions summarized in [Table 9](#).

**Table 27. PLL characteristics**

Symbol	Parameter	Min <sup>(1)</sup>	Max <sup>(1)</sup>	Unit
f <sub>PLL_IN</sub>	PLL input clock <sup>(2)</sup>	3	12	MHz
	Pulse width at high level	30	-	ns
f <sub>PLL_OUT</sub>	PLL multiplier output clock	18	72	MHz
f <sub>VCO_OUT</sub>	PLL VCO output	36	144	MHz
t <sub>LOCK</sub>	PLL lock time	-	350	µs
Jitter	Cycle-to-cycle jitter	-	300	ps

1. Based on characterization, not tested in production.
2. Take care of using the appropriate multiplier factors so as to have PLL input clock values compatible with the range defined by f<sub>PLL\_OUT</sub>.

**Table 28. PLL2 and PLL3 characteristics**

Symbol	Parameter	Min <sup>(1)</sup>	Max <sup>(1)</sup>	Unit
f <sub>PLL_IN</sub>	PLL input clock <sup>(2)</sup>	3	5	MHz
	Pulse width at high level	30	-	ns
f <sub>PLL_OUT</sub>	PLL multiplier output clock	40	74	MHz
f <sub>VCO_OUT</sub>	PLL VCO output	80	148	MHz
t <sub>LOCK</sub>	PLL lock time	-	350	µs
Jitter	Cycle-to-cycle jitter	-	400	ps

1. Based on characterization, not tested in production.
2. Take care of using the appropriate multiplier factors so as to have PLL input clock values compatible with the range defined by f<sub>PLL\_OUT</sub>.



### 5.3.9 Memory characteristics

#### Flash memory

The characteristics are given at  $T_A = -40$  to  $105$  °C unless otherwise specified.

**Table 29. Flash memory characteristics**

Symbol	Parameter	Conditions	Min <sup>(1)</sup>	Typ	Max <sup>(1)</sup>	Unit
$t_{prog}$	16-bit programming time	$T_A = -40$ to $+105$ °C	40	52.5	70	µs
$t_{ERASE}$	Page (1 KB) erase time	$T_A = -40$ to $+105$ °C	20	-	40	ms
$t_{ME}$	Mass erase time	$T_A = -40$ to $+105$ °C	20	-	40	ms
$I_{DD}$	Supply current	Read mode $f_{HCLK} = 72$ MHz with 2 wait states, $V_{DD} = 3.3$ V	-	-	20	mA
		Write / Erase modes $f_{HCLK} = 72$ MHz, $V_{DD} = 3.3$ V	-	-	5	mA
		Power-down mode / Halt, $V_{DD} = 3.0$ to $3.6$ V	-	-	50	µA
$V_{prog}$	Programming voltage	-	2	-	3.6	V

1. Guaranteed by design, not tested in production.

**Table 30. Flash memory endurance and data retention**

Symbol	Parameter	Conditions	Min <sup>(1)</sup>	Typ	Max <sup>(1)</sup>	Unit
$N_{END}$	Endurance	$T_A = -40$ to $+85$ °C (6 suffix versions) $T_A = -40$ to $+105$ °C (7 suffix versions)	10	-	-	Kcycles
$t_{RET}$	Data retention	1 kcycle <sup>(2)</sup> at $T_A = 85$ °C	30	-	-	Years
		1 kcycle <sup>(2)</sup> at $T_A = 105$ °C	10	-	-	
		10 kcycles <sup>(2)</sup> at $T_A = 55$ °C	20	-	-	

1. Based on characterization, not tested in production.

2. Cycling performed over the whole temperature range.

### 5.3.10 EMC characteristics

Susceptibility tests are performed on a sample basis during device characterization.

#### Functional EMS (electromagnetic susceptibility)

While a simple application is executed on the device (toggling 2 LEDs through I/O ports), the device is stressed by two electromagnetic events until a failure occurs. The failure is indicated by the LEDs:

- **Electrostatic discharge (ESD)** (positive and negative) is applied to all device pins until a functional disturbance occurs. This test is compliant with the IEC 61000-4-2 standard.
- **FTB**: A burst of fast transient voltage (positive and negative) is applied to  $V_{DD}$  and  $V_{SS}$  through a 100 pF capacitor, until a functional disturbance occurs. This test is compliant with the IEC 61000-4-4 standard.





A device reset allows normal operations to be resumed.

The test results are given in [Table 31](#). They are based on the EMS levels and classes defined in application note AN1709.

**Table 31. EMS characteristics**

Symbol	Parameter	Conditions	Level/Class
$V_{FESD}$	Voltage limits to be applied on any I/O pin to induce a functional disturbance	$V_{DD} = 3.3\text{ V}$ , LQFP100, $T_A = +25\text{ }^\circ\text{C}$ , $f_{HCLK} = 72\text{ MHz}$ , conforms to IEC 61000-4-2	2B
$V_{EFTB}$	Fast transient voltage burst limits to be applied through 100 pF on $V_{DD}$ and $V_{SS}$ pins to induce a functional disturbance	$V_{DD} = 3.3\text{ V}$ , LQFP100, $T_A = +25\text{ }^\circ\text{C}$ , $f_{HCLK} = 72\text{ MHz}$ , conforms to IEC 61000-4-4	4A

**Designing hardened software to avoid noise problems**

EMC characterization and optimization are performed at component level with a typical application environment and simplified MCU software. It should be noted that good EMC performance is highly dependent on the user application and the software in particular.

Therefore it is recommended that the user applies EMC software optimization and prequalification tests in relation with the EMC level requested for his application.

**Software recommendations**

The software flowchart must include the management of runaway conditions such as:

- Corrupted program counter
- Unexpected reset
- Critical Data corruption (control registers...)

**Prequalification trials**

Most of the common failures (unexpected reset and program counter corruption) can be reproduced by manually forcing a low state on the NRST pin or the Oscillator pins for 1 second.

To complete these trials, ESD stress can be applied directly on the device, over the range of specification values. When unexpected behavior is detected, the software can be hardened to prevent unrecoverable errors occurring (see application note AN1015).

**Electromagnetic Interference (EMI)**

The electromagnetic field emitted by the device are monitored while a simple application is executed (toggling 2 LEDs through the I/O ports). This emission test is compliant with IEC61967-2 standard which specifies the test board and the pin loading.



Table 32. EMI characteristics

Symbol	Parameter	Conditions	Monitored frequency band	Max vs. [f <sub>HSE</sub> /f <sub>HCLK</sub> ]		Unit
				8/48 MHz	8/72 MHz	
S <sub>EMI</sub>	Peak level	V <sub>DD</sub> = 3.3 V, T <sub>A</sub> = 25 °C, LQFP100 package compliant with IEC61967-2	0.1 to 30 MHz	9	9	dBμV
			30 to 130 MHz	26	13	
			130 MHz to 1GHz	25	31	
			EMI Level	4	4	-

5.3.11 Absolute maximum ratings (electrical sensitivity)

Based on three different tests (ESD, LU) using specific measurement methods, the device is stressed in order to determine its performance in terms of electrical sensitivity.

Electrostatic discharge (ESD)

Electrostatic discharges (a positive then a negative pulse separated by 1 second) are applied to the pins of each sample according to each pin combination. The sample size depends on the number of supply pins in the device (3 parts × (n+1) supply pins). This test conforms to the JESD22-A114/C101 standard.

Table 33. ESD absolute maximum ratings

Symbol	Ratings	Conditions	Class	Maximum value <sup>(1)</sup>	Unit
V <sub>ESD(HBM)</sub>	Electrostatic discharge voltage (human body model)	T <sub>A</sub> = +25 °C conforming to JESD22-A114	2	2000	V
V <sub>ESD(CDM)</sub>	Electrostatic discharge voltage (charge device model)	T <sub>A</sub> = +25 °C conforming to JESD22-C101	II	500	

1. Based on characterization results, not tested in production.

Static latch-up

Two complementary static tests are required on six parts to assess the latch-up performance:

- A supply overvoltage is applied to each power supply pin
- A current injection is applied to each input, output and configurable I/O pin

These tests are compliant with EIA/JESD 78A IC latch-up standard.

Table 34. Electrical sensitivities

Symbol	Parameter	Conditions	Class
LU	Static latch-up class	T <sub>A</sub> = +105 °C conforming to JESD78A	II level A

5.3.12 I/O current injection characteristics

As a general rule, current injection to the I/O pins, due to external voltage below V<sub>SS</sub> or above V<sub>DD</sub> (for standard, 3 V-capable I/O pins) should be avoided during normal product



operation. However, in order to give an indication of the robustness of the microcontroller in cases when abnormal injection accidentally happens, susceptibility tests are performed on a sample basis during device characterization.

**Functional susceptibility to I/O current injection**

While a simple application is executed on the device, the device is stressed by injecting current into the I/O pins programmed in floating input mode. While current is injected into the I/O pin, one at a time, the device is checked for functional failures.

The failure is indicated by an out of range parameter: ADC error above a certain limit (>5 LSB TUE), out of spec current injection on adjacent pins or other functional failure (for example reset, oscillator frequency deviation).

The test results are given in [Table 35](#)

**Table 35. I/O current injection susceptibility**

Symbol	Description	Functional susceptibility		Unit
		Negative injection	Positive injection	
I <sub>INJ</sub>	Injected current on OSC_IN32, OSC_OUT32, PA4, PA5, PC13	-0	+0	mA
	Injected current on all FT pins	-5	+0	
	Injected current on any other pin	-5	+5	

**5.3.13 I/O port characteristics**

**General input/output characteristics**

Unless otherwise specified, the parameters given in [Table 36](#) are derived from tests performed under the conditions summarized in [Table 9](#). All I/Os are CMOS and TTL compliant.

**Table 36. I/O static characteristics**

Symbol	Parameter	Conditions	Min	Typ	Max	Unit
V <sub>IL</sub>	Standard IO input low level voltage	-	-0.3	-	0.28*(V <sub>DD</sub> -2 V)+0.8 V	V
	IO FT <sup>(1)</sup> input low level voltage	-	-0.3	-	0.32*(V <sub>DD</sub> -2V)+0.75 V	V
V <sub>IH</sub>	Standard IO input high level voltage	-	0.41*(V <sub>DD</sub> -2 V)+1.3 V	-	V <sub>DD</sub> +0.3	V
	IO FT <sup>(1)</sup> input high level voltage	V <sub>DD</sub> > 2 V	0.42*(V <sub>DD</sub> -2 V)+1 V	-	5.5	V
		V <sub>DD</sub> ≤ 2 V			5.2	
V <sub>hys</sub>	Standard IO Schmitt trigger voltage hysteresis <sup>(2)</sup>	-	200	-	-	mV
	IO FT Schmitt trigger voltage hysteresis <sup>(2)</sup>	-	5% V <sub>DD</sub> <sup>(3)</sup>	-	-	mV



Table 36. I/O static characteristics (continued)

Symbol	Parameter		Conditions	Min	Typ	Max	Unit
I <sub>lkg</sub>	Input leakage current (4)		V <sub>SS</sub> ≤ V <sub>IN</sub> ≤ V <sub>DD</sub> Standard I/Os	-	-	±1	μA
			V <sub>IN</sub> = 5 V, I/O FT	-	-	3	
R <sub>PU</sub>	Weak pull-up equivalent resistor(5)	All pins except for PA10	V <sub>IN</sub> = V <sub>SS</sub>	30	40	50	k Ω
		PA10		8	11	15	
R <sub>PD</sub>	Weak pull-down equivalent resistor(5)	All pins except for PA10	V <sub>IN</sub> = V <sub>DD</sub>	30	40	50	k Ω
		PA10		8	11	15	
C <sub>IO</sub>	I/O pin capacitance		-	-	5	-	pF

1. FT = Five-volt tolerant. In order to sustain a voltage higher than V<sub>DD</sub>+0.3 the internal pull-up/pull-down resistors must be disabled.
2. Hysteresis voltage between Schmitt trigger switching levels. Based on characterization, not tested in production.
3. With a minimum of 100 mV.
4. Leakage could be higher than max. if negative current is injected on adjacent pins.
5. Pull-up and pull-down resistors are designed with a true resistance in series with a switchable PMOS/NMOS. This MOS/NMOS contribution to the series resistance is minimum (~10% order).

All I/Os are CMOS and TTL compliant (no software configuration required). Their characteristics cover more than the strict CMOS-technology or TTL parameters. The coverage of these requirements is shown in [Figure 18](#) and [Figure 19](#) for standard I/Os, and in [Figure 20](#) and [Figure 21](#) for 5 V tolerant I/Os.

Figure 18. Standard I/O input characteristics - CMOS port

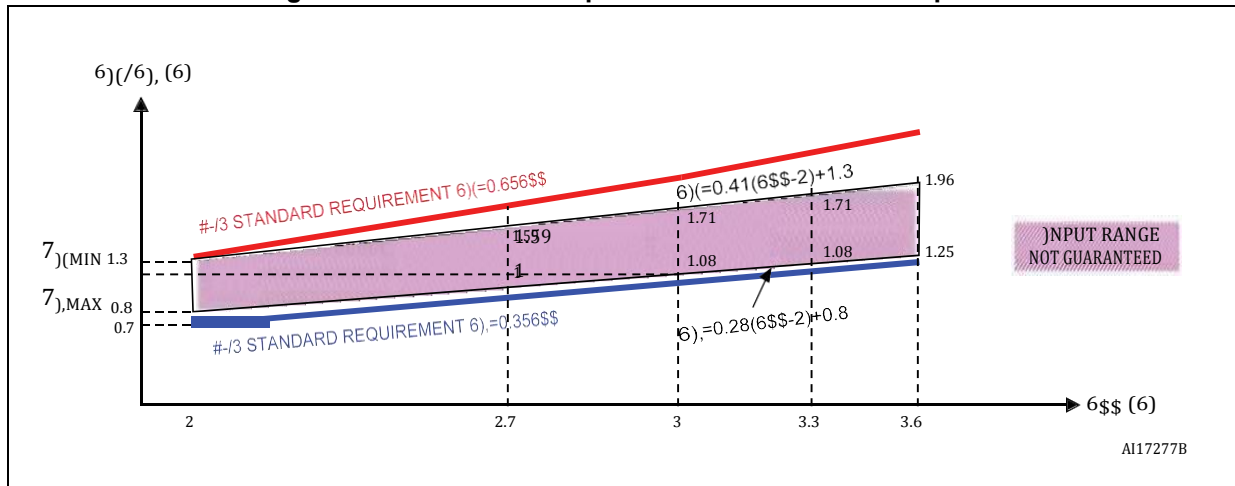






Figure 19. Standard I/O input characteristics - TTL port

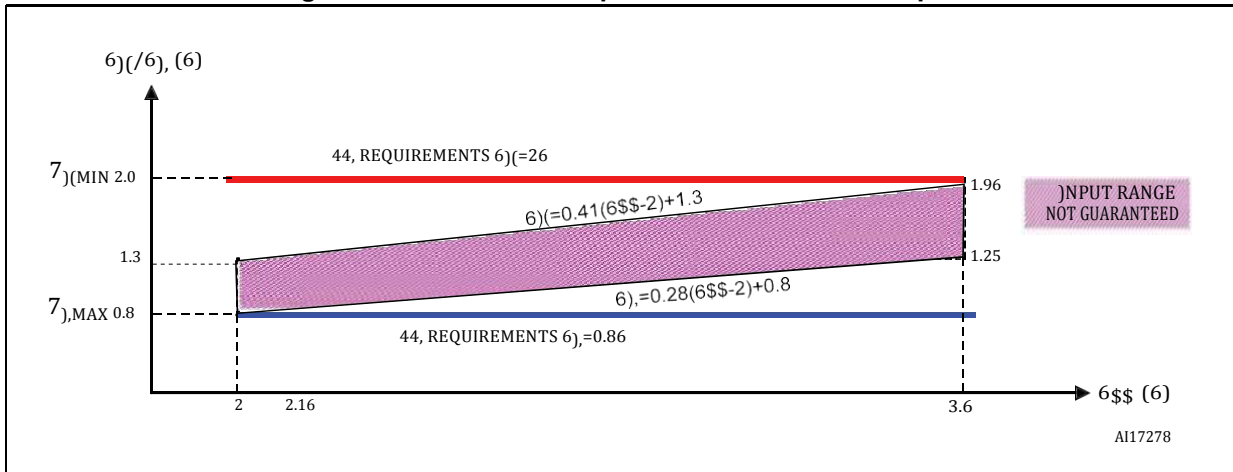


Figure 20. 5 V tolerant I/O input characteristics - CMOS port

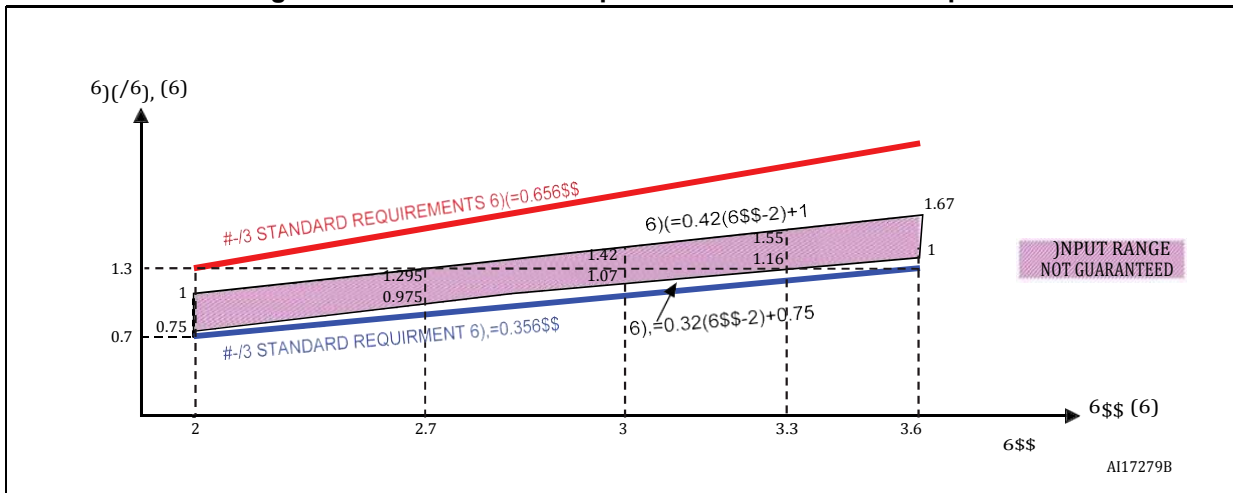
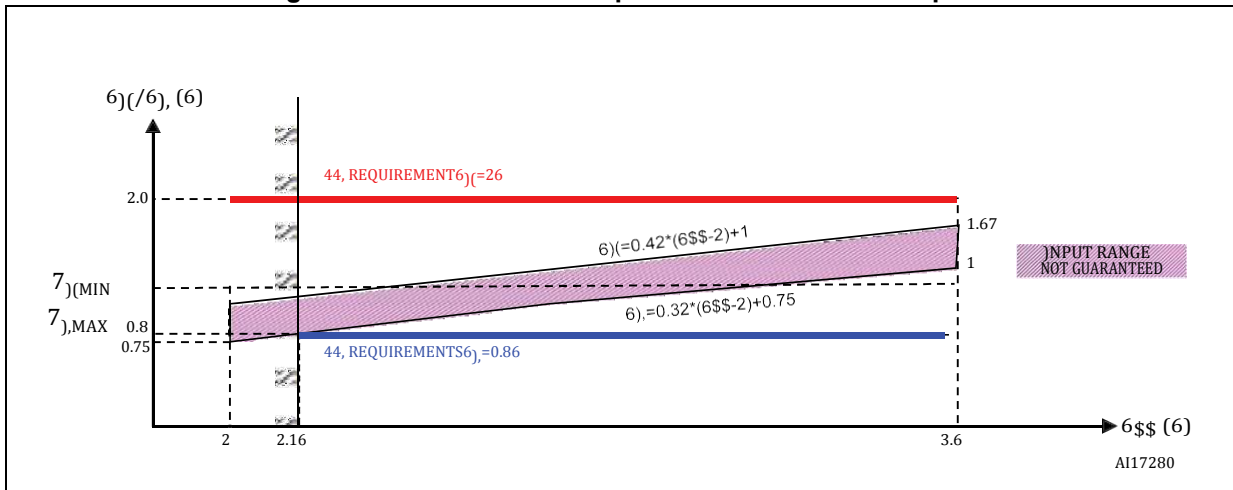


Figure 21. 5 V tolerant I/O input characteristics - TTL port





### Output driving current

The GPIOs (general purpose input/outputs) can sink or source up to +/-8 mA, and sink or source up to +/-20 mA (with a relaxed  $V_{OL}/V_{OH}$ ).

In the user application, the number of I/O pins which can drive current must be limited to respect the absolute maximum rating specified in [Section 5.2](#):

- The sum of the currents sourced by all the I/Os on  $V_{DD}$ , plus the maximum Run consumption of the MCU sourced on  $V_{DD}$ , cannot exceed the absolute maximum rating  $I_{VDD}$  (see [Table 7](#)).
- The sum of the currents sunk by all the I/Os on  $V_{SS}$  plus the maximum Run consumption of the MCU sunk on  $V_{SS}$  cannot exceed the absolute maximum rating  $I_{VSS}$  (see [Table 7](#)).

### Output voltage levels

Unless otherwise specified, the parameters given in [Table 37](#) are derived from tests performed under ambient temperature and  $V_{DD}$  supply voltage conditions summarized in [Table 9](#). All I/Os are CMOS and TTL compliant.

**Table 37. Output voltage characteristics**

Symbol	Parameter	Conditions	Min	Max	Unit
$V_{OL}^{(1)}$	Output low level voltage for an I/O pin when 8 pins are sunk at same time	TTL port $I_{IO} = +8 \text{ mA}$ $2.7 \text{ V} < V_{DD} < 3.6 \text{ V}$	-	0.4	V
$V_{OH}^{(2)}$	Output high level voltage for an I/O pin when 8 pins are sourced at same time		$V_{DD}-0.4$	-	
$V_{OL}^{(1)}$	Output low level voltage for an I/O pin when 8 pins are sunk at same time	CMOS port $I_{IO} = +8 \text{ mA}$ $2.7 \text{ V} < V_{DD} < 3.6 \text{ V}$	-	0.4	V
$V_{OH}^{(2)}$	Output high level voltage for an I/O pin when 8 pins are sourced at same time		2.4	-	
$V_{OL}^{(1)(3)}$	Output low level voltage for an I/O pin when 8 pins are sunk at same time	$I_{IO} = +20 \text{ mA}$ $2.7 \text{ V} < V_{DD} < 3.6 \text{ V}$	-	1.3	V
$V_{OH}^{(2)(3)}$	Output high level voltage for an I/O pin when 8 pins are sourced at same time		$V_{DD}-1.3$	-	
$V_{OL}^{(1)(3)}$	Output low level voltage for an I/O pin when 8 pins are sunk at same time	$I_{IO} = +6 \text{ mA}$ $2 \text{ V} < V_{DD} < 2.7 \text{ V}$	-	0.4	V
$V_{OH}^{(2)(3)}$	Output high level voltage for an I/O pin when 8 pins are sourced at same time		$V_{DD}-0.4$	-	

1. The  $I_{IO}$  current sunk by the device must always respect the absolute maximum rating specified in [Table 7](#) and the sum of  $I_{IO}$  (I/O ports and control pins) must not exceed  $I_{VSS}$ .
2. The  $I_{IO}$  current sourced by the device must always respect the absolute maximum rating specified in [Table 7](#) and the sum of  $I_{IO}$  (I/O ports and control pins) must not exceed  $I_{VDD}$ .
3. Based on characterization data, not tested in production.



**Input/output AC characteristics**

The definition and values of input/output AC characteristics are given in [Figure 22](#) and [Table 38](#), respectively.

Unless otherwise specified, the parameters given in [Table 38](#) are derived from tests performed under the ambient temperature and V<sub>DD</sub> supply voltage conditions summarized in [Table 9](#).

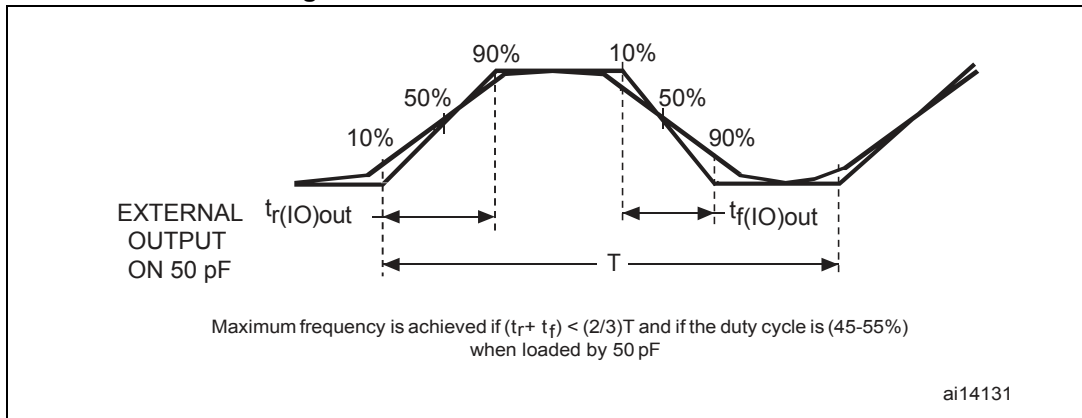
**Table 38. I/O AC characteristics<sup>(1)</sup>**

MODEx[1:0] bit value <sup>(1)</sup>	Symbol	Parameter	Conditions	Min	Max	Unit
10	f <sub>max(IO)out</sub>	Maximum frequency <sup>(2)</sup>	C <sub>L</sub> = 50 pF, V <sub>DD</sub> = 2 V to 3.6 V	-	2	MHz
	t <sub>f(IO)out</sub>	Output high to low level fall time	C <sub>L</sub> = 50 pF, V <sub>DD</sub> = 2 V to 3.6 V	-	125 <sup>(3)</sup>	ns
	t <sub>r(IO)out</sub>	Output low to high level rise time		-	125 <sup>(3)</sup>	
01	f <sub>max(IO)out</sub>	Maximum frequency <sup>(2)</sup>	C <sub>L</sub> = 50 pF, V <sub>DD</sub> = 2 V to 3.6 V	-	10	MHz
	t <sub>f(IO)out</sub>	Output high to low level fall time	C <sub>L</sub> = 50 pF, V <sub>DD</sub> = 2 V to 3.6 V	-	25 <sup>(3)</sup>	ns
	t <sub>r(IO)out</sub>	Output low to high level rise time		-	25 <sup>(3)</sup>	
11	F <sub>max(IO)out</sub>	Maximum frequency <sup>(2)</sup>	C <sub>L</sub> = 30 pF, V <sub>DD</sub> = 2.7 V to 3.6 V	-	50	MHz
			C <sub>L</sub> = 50 pF, V <sub>DD</sub> = 2.7 V to 3.6 V	-	30	MHz
			C <sub>L</sub> = 50 pF, V <sub>DD</sub> = 2 V to 2.7 V	-	20	MHz
	t <sub>f(IO)out</sub>	Output high to low level fall time	C <sub>L</sub> = 30 pF, V <sub>DD</sub> = 2.7 V to 3.6 V	-	5 <sup>(3)</sup>	ns
			C <sub>L</sub> = 50 pF, V <sub>DD</sub> = 2.7 V to 3.6 V	-	8 <sup>(3)</sup>	
			C <sub>L</sub> = 50 pF, V <sub>DD</sub> = 2 V to 2.7 V	-	12 <sup>(3)</sup>	
	t <sub>r(IO)out</sub>	Output low to high level rise time	C <sub>L</sub> = 30 pF, V <sub>DD</sub> = 2.7 V to 3.6 V	-	5 <sup>(3)</sup>	ns
			C <sub>L</sub> = 50 pF, V <sub>DD</sub> = 2.7 V to 3.6 V	-	8 <sup>(3)</sup>	
			C <sub>L</sub> = 50 pF, V <sub>DD</sub> = 2 V to 2.7 V	-	12 <sup>(3)</sup>	
-	t <sub>EXTIpw</sub>	Pulse width of external signals detected by the EXTI controller	-	10	-	ns

1. The I/O speed is configured using the MODEx[1:0] bits. Refer to the STM32F10xxx reference manual for a description of GPIO Port configuration register.
2. The maximum frequency is defined in [Figure 22](#).
3. Guaranteed by design, not tested in production.



Figure 22. I/O AC characteristics definition



### 5.3.14 NRST pin characteristics

The NRST pin input driver uses CMOS technology. It is connected to a permanent pull-up resistor,  $R_{PU}$  (see [Table 36](#)).

Unless otherwise specified, the parameters given in [Table 39](#) are derived from tests performed under the ambient temperature and  $V_{DD}$  supply voltage conditions summarized in [Table 9](#).

Table 39. NRST pin characteristics

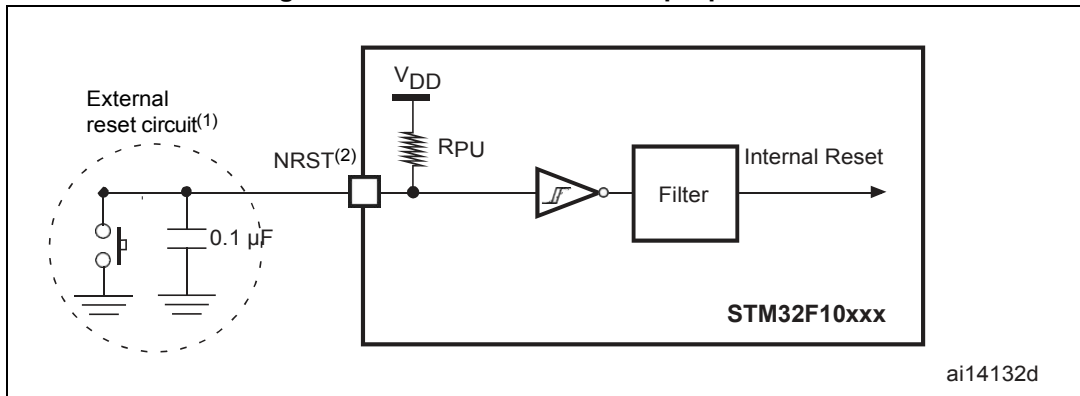
Symbol	Parameter	Conditions	Min	Typ	Max	Unit
$V_{IL(NRST)}$ <sup>(1)</sup>	NRST Input low level voltage	-	-0.5	-	0.8	V
$V_{IH(NRST)}$	NRST Input high level voltage	-	2	-	$V_{DD}+0.5$	
$V_{hys(NRST)}$	NRST Schmitt trigger voltage hysteresis	-	-	200	-	mV
$R_{PU}$	Weak pull-up equivalent resistor <sup>(2)</sup>	$V_{IN} = V_{SS}$	30	40	50	k $\Omega$
$V_{F(NRST)}$ <sup>(1)</sup>	NRST Input filtered pulse	-	-	-	100	ns
$V_{NF(NRST)}$ <sup>(1)</sup>	NRST Input not filtered pulse	$V_{DD} > 2.7 V$	300	-	-	ns

1. Guaranteed by design, not tested in production.
2. The pull-up is designed with a true resistance in series with a switchable PMOS. This PMOS contribution to the series resistance must be minimum (~10% order).





Figure 23. Recommended NRST pin protection



2. The reset network protects the device against parasitic resets.
3. The user must ensure that the level on the NRST pin can go below the  $V_{IL(NRST)}$  max level specified in [Table 39](#). Otherwise the reset will not be taken into account by the device.

### 5.3.15 TIM timer characteristics

The parameters given in [Table 40](#) are guaranteed by design.

Refer to [Section 5.3.12: I/O current injection characteristics](#) for details on the input/output alternate function characteristics (output compare, input capture, external clock, PWM output).

Table 40. TIMx<sup>(1)</sup> characteristics

Symbol	Parameter	Conditions	Min	Max	Unit
$t_{res(TIM)}$	Timer resolution time	-	1	-	$t_{TIMxCLK}$
		$f_{TIMxCLK} = 72 \text{ MHz}$	13.9	-	ns
$f_{EXT}$	Timer external clock frequency on CH1 to CH4	-	0	$f_{TIMxCLK}/2$	MHz
		$f_{TIMxCLK} = 72 \text{ MHz}$	0	36	MHz
$Re_{TIM}$	Timer resolution	-	-	16	bit
$t_{COUNTER}$	16-bit counter clock period when internal clock is selected	-	1	65536	$t_{TIMxCLK}$
		$f_{TIMxCLK} = 72 \text{ MHz}$	0.0139	910	$\mu\text{s}$
$t_{MAX\_COUNT}$	Maximum possible count	-	-	$65536 \times 65536$	$t_{TIMxCLK}$
		$f_{TIMxCLK} = 72 \text{ MHz}$	-	59.6	s

1. TIMx is used as a general term to refer to the TIM1, TIM2, TIM3, TIM4 and TIM5 timers.



### 5.3.16 Communications interfaces

#### I<sup>2</sup>C interface characteristics

Unless otherwise specified, the parameters given in [Table 41](#) are derived from tests performed under the ambient temperature,  $f_{PCLK1}$  frequency and  $V_{DD}$  supply voltage conditions summarized in [Table 9](#).

The STM32F105xx and STM32F107xx I<sup>2</sup>C interface meets the requirements of the standard I<sup>2</sup>C communication protocol with the following restrictions: the I/O pins SDA and SCL are mapped to are not “true” open-drain. When configured as open-drain, the PMOS connected between the I/O pin and  $V_{DD}$  is disabled, but is still present.

The I<sup>2</sup>C characteristics are described in [Table 41](#). Refer also to [Section 5.3.12: I/O current injection characteristics](#) for more details on the input/output alternate function characteristics (SDA and SCL).

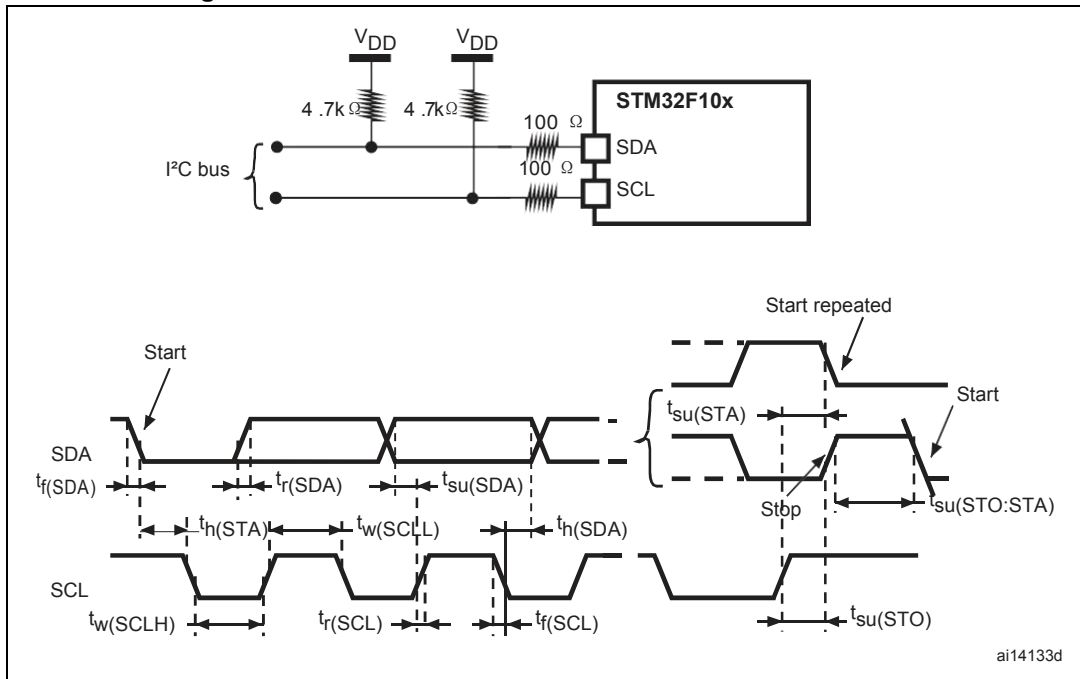
**Table 41. I<sup>2</sup>C characteristics**

Symbol	Parameter	Standard mode I <sup>2</sup> C <sup>(1)</sup>		Fast mode I <sup>2</sup> C <sup>(1)(2)</sup>		Unit
		Min	Max	Min	Max	
$t_{w(SCLL)}$	SCL clock low time	4.7	-	1.3	-	μs
$t_{w(SCLH)}$	SCL clock high time	4.0	-	0.6	-	
$t_{su(SDA)}$	SDA setup time	250	-	100	-	ns
$t_{h(SDA)}$	SDA data hold time	0 <sup>(3)</sup>	-	0 <sup>(4)</sup>	900 <sup>(3)</sup>	
$t_{r(SDA)}$ $t_{r(SCL)}$	SDA and SCL rise time	-	1000	$20 + 0.1C_b$	300	
$t_{f(SDA)}$ $t_{f(SCL)}$	SDA and SCL fall time	-	300	-	300	
$t_{h(STA)}$	Start condition hold time	4.0	-	0.6	-	μs
$t_{su(STA)}$	Repeated Start condition setup time	4.7	-	0.6	-	
$t_{su(STO)}$	Stop condition setup time	4.0	-	0.6	-	μs
$t_{w(STO:STA)}$	Stop to Start condition time (bus free)	4.7	-	1.3	-	μs
$C_b$	Capacitive load for each bus line	-	400	-	400	pF

1. Guaranteed by design, not tested in production.
2.  $f_{PCLK1}$  must be at least 2 MHz to achieve standard mode I<sup>2</sup>C frequencies. It must be at least 4 MHz to achieve the fast mode I<sup>2</sup>C frequencies and it must be a multiple of 10 MHz in order to reach I<sup>2</sup>C fast mode maximum clock 400 kHz.
3. The maximum hold time of the Start condition has only to be met if the interface does not stretch the low period of SCL signal.
4. The device must internally provide a hold time of at least 300ns for the SDA signal in order to bridge the undefined region of the falling edge of SCL.



Figure 24. I<sup>2</sup>C bus AC waveforms and measurement circuit



1. Measurement points are done at CMOS levels: 0.3V<sub>DD</sub> and 0.7V<sub>DD</sub>.

Table 42. SCL frequency (f<sub>PCLK1</sub>= 36 MHz., V<sub>DD</sub> = 3.3 V)<sup>(1)(2)</sup>

f <sub>SCL</sub> (kHz)	I2C_CCR value
	R <sub>P</sub> = 4.7 kΩ
400	0x801E
300	0x8028
200	0x803C
100	0x00B4
50	0x0168
20	0x0384

1. R<sub>P</sub> = External pull-up resistance, f<sub>SCL</sub> = I<sup>2</sup>C speed,
2. For speeds around 200 kHz, the tolerance on the achieved speed is of ±5%. For other speed ranges, the tolerance on the achieved speed ±2%. These variations depend on the accuracy of the external components used to design the application.



**I<sup>2</sup>S - SPI interface characteristics**

Unless otherwise specified, the parameters given in [Table 43](#) for SPI or in [Table 44](#) for I<sup>2</sup>S are derived from tests performed under the ambient temperature,  $f_{PCLKx}$  frequency and  $V_{DD}$  supply voltage conditions summarized in [Table 9](#).

Refer to [Section 5.3.12: I/O current injection characteristics](#) for more details on the input/output alternate function characteristics (NSS, SCK, MOSI, MISO for SPI and WS, CK, SD for I<sup>2</sup>S).

**Table 43. SPI characteristics**

Symbol	Parameter	Conditions	Min	Max	Unit
$f_{SCK}$ $1/t_{c(SCK)}$	SPI clock frequency	Master mode	-	18	MHz
		Slave mode	-	18	
$t_{r(SCK)}$ $t_{f(SCK)}$	SPI clock rise and fall time	Capacitive load: C = 30 pF	-	8	ns
DuCy(SCK)	SPI slave input clock duty cycle	Slave mode	30	70	%
$t_{su(NSS)}$	NSS setup time	Slave mode	$4 t_{PCLK}$	-	ns
$t_{h(NSS)}$	NSS hold time	Slave mode	$2 t_{PCLK}$	-	
$t_{w(SCKH)}$ $t_{w(SCKL)}$	SCK high and low time	Master mode, $f_{PCLK} = 36$ MHz, presc = 4	50	60	
$t_{su(MI)}$	Data input setup time	Master mode	4	-	
$t_{su(SI)}$		Slave mode	5	-	
$t_{h(MI)}$	Data input hold time	Master mode	5	-	
$t_{h(SI)}$		Slave mode	5	-	
$t_{a(SO)}$	Data output access time	Slave mode, $f_{PCLK} = 20$ MHz	-	$3 * t_{PCLK}$	
$t_{v(SO)}$	Data output valid time	Slave mode (after enable edge)	-	34	
$t_{v(MO)}$	Data output valid time	Master mode (after enable edge)	-	8	
$t_{h(SO)}$	Data output hold time	Slave mode (after enable edge)	32	-	
$t_{h(MO)}$		Master mode (after enable edge)	10	-	





Figure 25. SPI timing diagram - slave mode and CPHA = 0

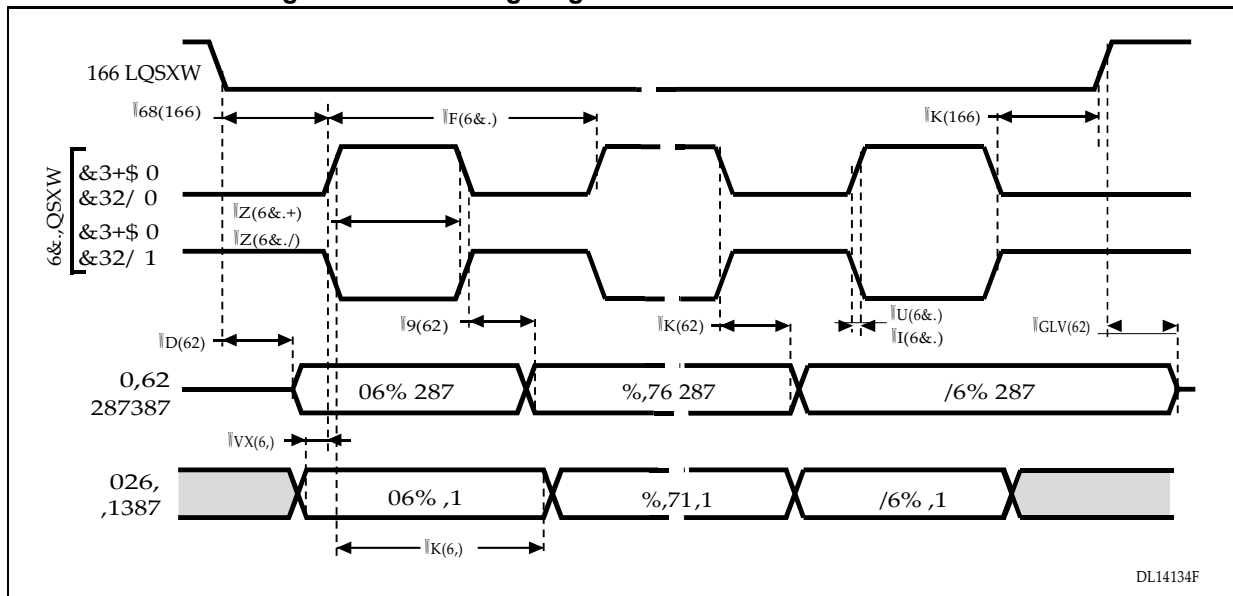
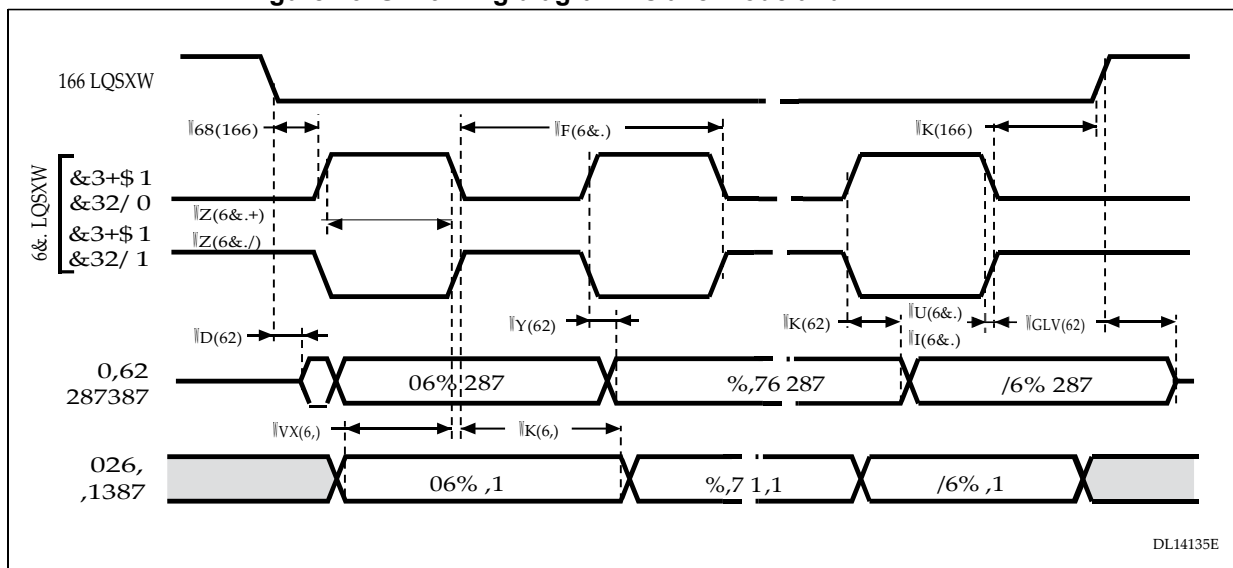


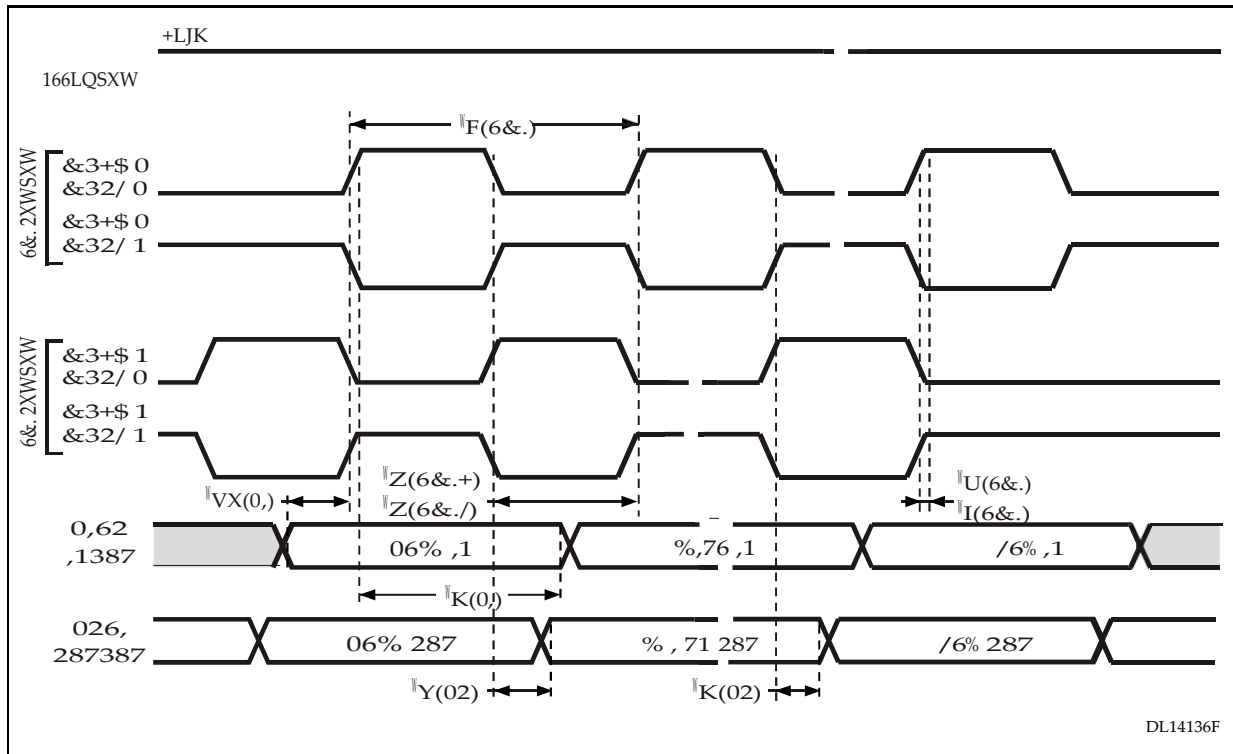
Figure 26. SPI timing diagram - slave mode and CPHA = 1<sup>(1)</sup>



1. Measurement points are done at CMOS levels: 0.3V<sub>DD</sub> and 0.7V<sub>DD</sub>.



Figure 27. SPI timing diagram - master mode<sup>(1)</sup>



1. Measurement points are done at CMOS levels:  $0.3V_{DD}$  and  $0.7V_{DD}$ .



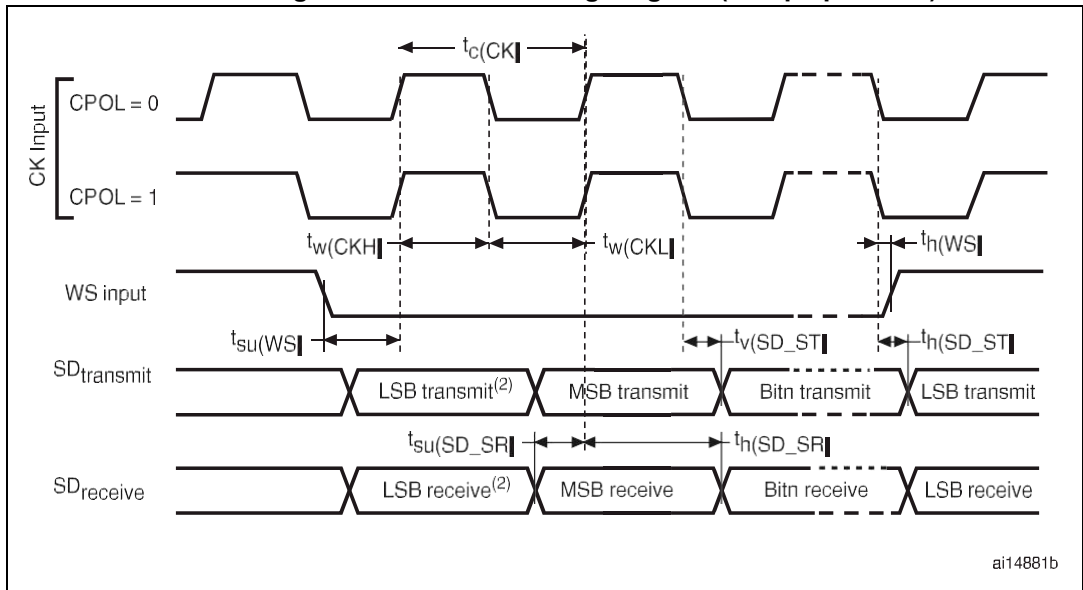
Table 44. I<sup>2</sup>S characteristics

Symbol	Parameter	Conditions	Min	Max	Unit	
$f_{CK}$ $1/t_{c(CK)}$	I <sup>2</sup> S clock frequency	Master data: 16 bits, audio freq = 48 K	1.52	1.54	MHz	
		Slave	0	6.5		
$t_{r(CK)}$ $t_{f(CK)}$	I <sup>2</sup> S clock rise and fall time	capacitive load $C_L = 50$ pF	-	8	ns	
$t_{w(CK_H)}$	I <sup>2</sup> S clock high time	Master $f_{PCLK} = 16$ MHz, audio freq = 48 K	317	320		
$t_{w(CK_L)}$	I <sup>2</sup> S clock low time		333	336		
$t_{v(WS)}^{(1)}$	WS valid time	Master mode	3	-		
$t_{h(WS)}^{(1)}$	WS hold time	Master mode	I2S2	0		-
			I2S3	0		-
$t_{su(WS)}^{(1)}$	WS setup time	Slave mode	I2S2	4	-	
			I2S3	9	-	
$t_{h(WS)}^{(1)}$	WS hold time	Slave mode	0	-		
DuCy(SCK)	I2S slave input clock duty cycle	Slave mode	30	70	%	
$t_{su(SD\_MR)}^{(1)}$	Data input setup time	Master receiver	I2S2	8	-	
			I2S3	10	-	
Slave receiver		I2S2	3	-		
		I2S3	8	-		
$t_{su(SD\_SR)}^{(1)}$						
$t_{h(SD\_M\_R)}^{(1)}$	Data input hold time	Master receiver	I2S2	2	-	
			I2S3	4	-	
Slave receiver		I2S2	2	-		
		I2S3	4	-		
$t_{h(SD\_SR)}^{(1)}$						
$t_{v(SD\_ST)}^{(1)(3)}$	Data output valid time	Slave transmitter (after enable edge)	I2S2	23	-	
			I2S3	33	-	
$t_{h(SD\_ST)}^{(1)}$	Data output hold time	Slave transmitter (after enable edge)	I2S2	29	-	
			I2S3	27	-	
$t_{v(SD\_MT)}^{(1)}$	Data output valid time	Master transmitter (after enable edge)	I2S2	-	5	
			I2S3	-	2	
$t_{h(SD\_MT)}^{(1)}$	Data output hold time	Master transmitter (after enable edge)	I2S2	11	-	
			I2S3	4	-	

1. Based on design simulation and/or characterization results, not tested in production.

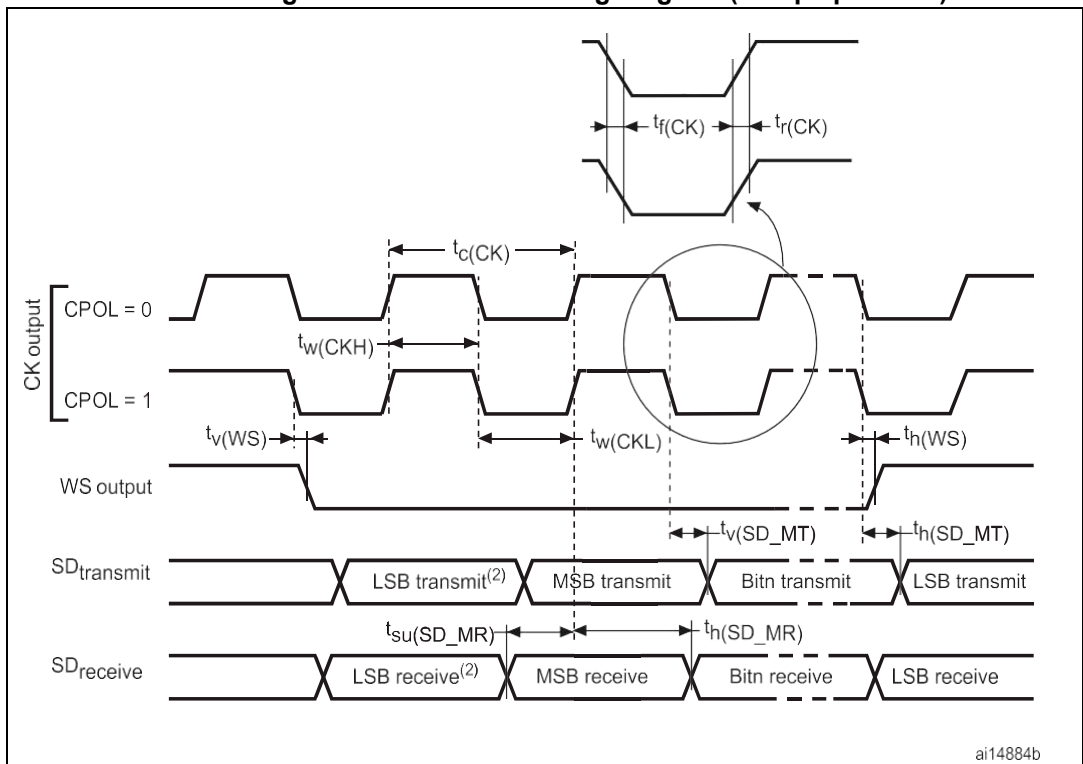


Figure 28. I<sup>2</sup>S slave timing diagram (Philips protocol)<sup>(1)</sup>



1. Measurement points are done at CMOS levels:  $0.3 \times V_{DD}$  and  $0.7 \times V_{DD}$ .
2. LSB transmit/receive of the previously transmitted byte. No LSB transmit/receive is sent before the first byte.

Figure 29. I<sup>2</sup>S master timing diagram (Philips protocol)<sup>(1)</sup>



1. Based on characterization, not tested in production.
2. LSB transmit/receive of the previously transmitted byte. No LSB transmit/receive is sent before the first byte.





**USB OTG FS characteristics**

The USB OTG interface is USB-IF certified (Full-Speed).

**Table 45. USB OTG FS startup time**

Symbol	Parameter	Max	Unit
$t_{STARTUP}^{(1)}$	USB OTG FS transceiver startup time	1	$\mu s$

1. Guaranteed by design, not tested in production.

**Table 46. USB OTG FS DC electrical characteristics**

Symbol	Parameter	Conditions	Min. <sup>(1)</sup>	Typ.	Max. <sup>(1)</sup>	Unit	
Input levels	$V_{DD}$	USB OTG FS operating voltage	-	3.0 <sup>(2)</sup>	-	3.6	V
	$V_{DI}^{(3)}$	Differential input sensitivity	I(USBDP, USBDM)	0.2	-	-	V
	$V_{CM}^{(3)}$	Differential common mode range	Includes $V_{DI}$ range	0.8	-	2.5	
	$V_{SE}^{(3)}$	Single ended receiver threshold	-	1.3	-	2.0	
Output levels	$V_{OL}$	Static output level low	$R_L$ of 1.5 k $\Omega$ to 3.6 V <sup>(4)</sup>	-	-	0.3	V
	$V_{OH}$	Static output level high	$R_L$ of 15 k $\Omega$ to $V_{SS}^{(4)}$	2.8	-	3.6	
$R_{PD}$	Pull-down resistance on PA11, PA12	$V_{IN} = V_{DD}$	17	21	24	k $\Omega$	
	Pull-down resistance on PA9		0.65	1.1	2.0		
$R_{PU}$	Pull-up resistance on PA12	$V_{IN} = V_{SS}$	1.5	1.8	2.1		
	Pull-up resistance on PA9	$V_{IN} = V_{SS}$	0.25	0.37	0.55		

1. All the voltages are measured from the local ground potential.
2. The STM32F105xx and STM32F107xx USB OTG FS functionality is ensured down to 2.7 V but not the full USB OTG FS electrical characteristics which are degraded in the 2.7-to-3.0 V  $V_{DD}$  voltage range.
3. Guaranteed by design, not tested in production.
4.  $R_L$  is the load connected on the USB OTG FS drivers

**Figure 30. USB OTG FS timings: definition of data signal rise and fall time**

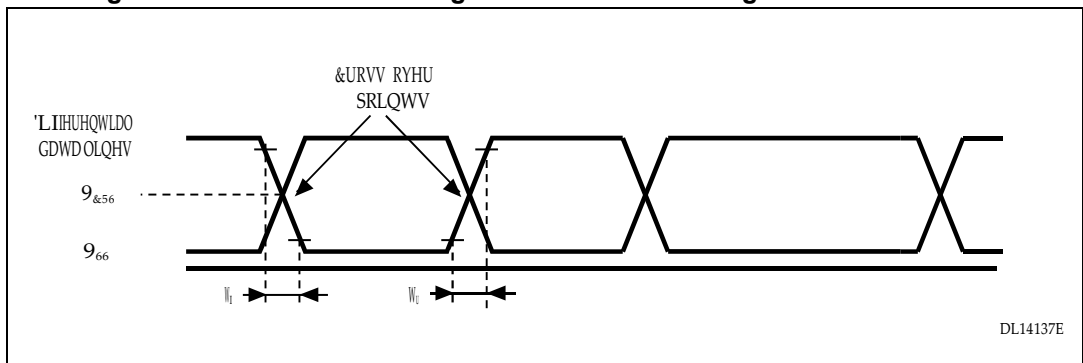




Table 47. USB OTG FS electrical characteristics<sup>(1)</sup>

Driver characteristics					
Symbol	Parameter	Conditions	Min	Max	Unit
$t_r$	Rise time <sup>(2)</sup>	$C_L = 50 \text{ pF}$	4	20	ns
$t_f$	Fall time <sup>(2)</sup>	$C_L = 50 \text{ pF}$	4	20	ns
$t_{rfm}$	Rise/ fall time matching	$t_r/t_f$	90	110	%
$V_{CRS}$	Output signal crossover voltage	-	1.3	2.0	V

1. Guaranteed by design, not tested in production.
2. Measured from 10% to 90% of the data signal. For more detailed informations, refer to USB Specification - Chapter 7 (version 2.0).

**Ethernet characteristics**

Table 48 shows the Ethernet operating voltage.

Table 48. Ethernet DC electrical characteristics

Symbol	Parameter	Min. <sup>(1)</sup>	Max. <sup>(1)</sup>	Unit
Input level $V_{DD}$	Ethernet operating voltage	3.0	3.6	V

1. All the voltages are measured from the local ground potential.

Table 49 gives the list of Ethernet MAC signals for the SMI (station management interface) and Figure 31 shows the corresponding timing diagram.

Figure 31. Ethernet SMI timing diagram

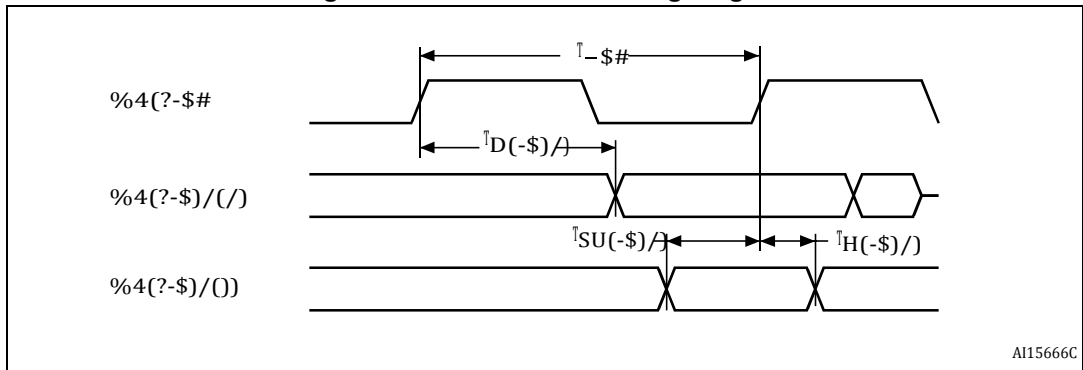


Table 49. Dynamic characteristics: Ethernet MAC signals for SMI

Symbol	Rating	Min	Typ	Max	Unit
$t_{MDC}$	MDC cycle time (1.71 MHz, AHB = 72 MHz)	583	583.5	584	ns
$t_{d(MDIO)}$	MDIO write data valid time	13.5	14.5	15.5	ns
$t_{su(MDIO)}$	Read data setup time	35	-	-	ns
$t_{h(MDIO)}$	Read data hold time	0	-	-	ns



Table 50 gives the list of Ethernet MAC signals for the RMII and Figure 32 shows the corresponding timing diagram.

Figure 32. Ethernet RMII timing diagram

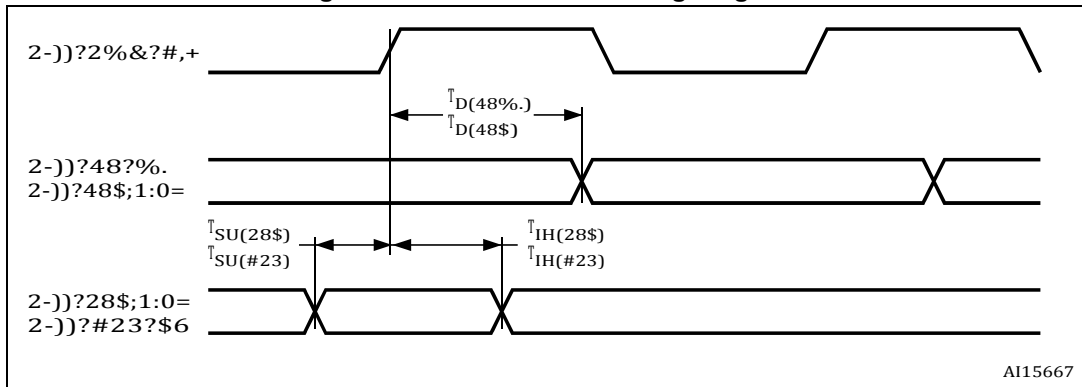


Table 50. Dynamic characteristics: Ethernet MAC signals for RMII

Symbol	Rating	Min	Typ	Max	Unit
$t_{su}(RXD)$	Receive data setup time	4	-	-	ns
$t_{ih}(RXD)$	Receive data hold time	2	-	-	ns
$t_{su}(DV)$	Carrier sense set-up time	4	-	-	ns
$t_{ih}(DV)$	Carrier sense hold time	2	-	-	ns
$t_d(TXEN)$	Transmit enable valid delay time	8	10	16	ns
$t_d(TXD)$	Transmit data valid delay time	7	10	16	ns

Table 51 gives the list of Ethernet MAC signals for MII and Figure 33 shows the corresponding timing diagram.

Figure 33. Ethernet MII timing diagram

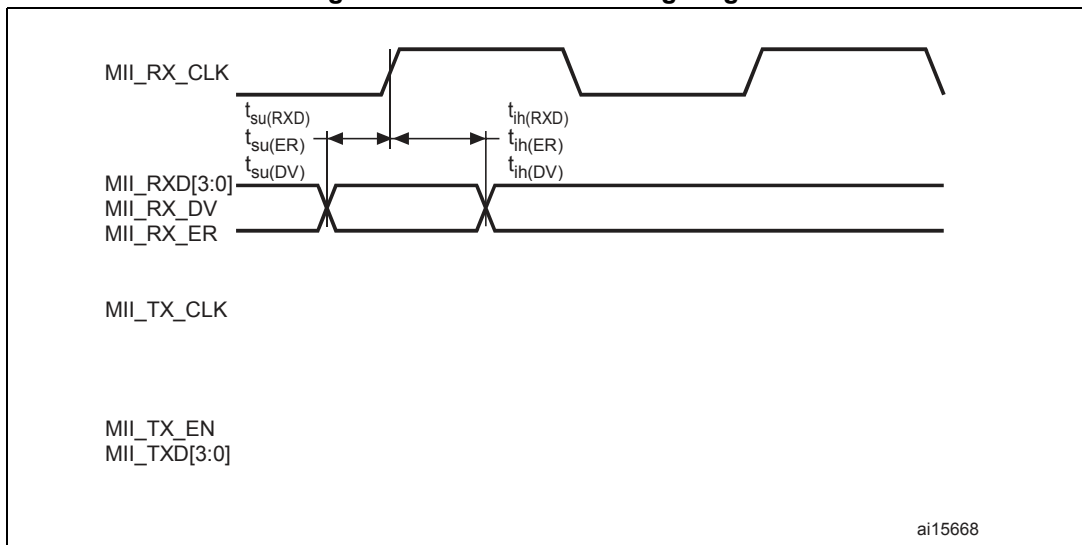




Table 51. Dynamic characteristics: Ethernet MAC signals for MII

Symbol	Rating	Min	Typ	Max	Unit
$t_{su}(RXD)$	Receive data setup time	10	-	-	ns
$t_{ih}(RXD)$	Receive data hold time	10	-	-	ns
$t_{su}(DV)$	Data valid setup time	10	-	-	ns
$t_{ih}(DV)$	Data valid hold time	10	-	-	ns
$t_{su}(ER)$	Error setup time	10	-	-	ns
$t_{ih}(ER)$	Error hold time	10	-	-	ns
$t_d(TXEN)$	Transmit enable valid delay time	14	16	18	ns
$t_d(TXD)$	Transmit data valid delay time	13	16	20	ns

### CAN (controller area network) interface

Refer to [Section 5.3.12: I/O current injection characteristics](#) for more details on the input/output alternate function characteristics (CANTX and CANRX).

### 5.3.17 12-bit ADC characteristics

Unless otherwise specified, the parameters given in [Table 52](#) are derived from tests performed under the ambient temperature,  $f_{PCLK2}$  frequency and  $V_{DDA}$  supply voltage conditions summarized in [Table 9](#).

*Note:* It is recommended to perform a calibration after each power-up.

Table 52. ADC characteristics

Symbol	Parameter	Conditions	Min	Typ	Max	Unit
$V_{DDA}$	Power supply	-	2.4	-	3.6	V
$V_{REF+}$	Positive reference voltage	-	2.4	-	$V_{DDA}$	V
$I_{VREF}$	Current on the $V_{REF}$ input pin	-	-	160 <sup>(1)</sup>	220 <sup>(1)</sup>	$\mu$ A
$f_{ADC}$	ADC clock frequency	-	0.6	-	14	MHz
$f_s^{(2)}$	Sampling rate	-	0.05	-	1	MHz
$f_{TRIG}^{(2)}$	External trigger frequency	$f_{ADC} = 14$ MHz	-	-	823	kHz
		-	-	-	17	$1/f_{ADC}$
$V_{AIN}$	Conversion voltage range <sup>(3)</sup>	-	0 ( $V_{SSA}$ or $V_{REF-}$ tied to ground)	-	$V_{REF+}$	V
$R_{AIN}^{(2)}$	External input impedance	See <a href="#">Equation 1</a> and <a href="#">Table 53</a> for details	-	-	50	$k\Omega$
$R_{ADC}^{(2)}$	Sampling switch resistance	-	-	-	1	$k\Omega$
$C_{ADC}^{(2)}$	Internal sample and hold capacitor	-	-	-	8	pF
$t_{CAL}^{(2)}$	Calibration time	$f_{ADC} = 14$ MHz	5.9			$\mu$ s
		-	83			$1/f_{ADC}$





**Table 52. ADC characteristics (continued)**

Symbol	Parameter	Conditions	Min	Typ	Max	Unit
t <sub>lat</sub> <sup>(2)</sup>	Injection trigger conversion latency	f <sub>ADC</sub> = 14 MHz	-	-	0.214	µs
		-	-	-	3 <sup>(4)</sup>	1/f <sub>ADC</sub>
t <sub>latr</sub> <sup>(2)</sup>	Regular trigger conversion latency	f <sub>ADC</sub> = 14 MHz	-	-	0.143	µs
		-	-	-	2 <sup>(4)</sup>	1/f <sub>ADC</sub>
t <sub>S</sub> <sup>(2)</sup>	Sampling time	f <sub>ADC</sub> = 14 MHz	0.107	-	17.1	µs
		-	1.5	-	239.5	1/f <sub>ADC</sub>
t <sub>STAB</sub> <sup>(2)</sup>	Power-up time	-	0	0	1	µs
t <sub>CONV</sub> <sup>(2)</sup>	Total conversion time (including sampling time)	f <sub>ADC</sub> = 14 MHz	1	-	18	µs
		-	14 to 252 (t <sub>s</sub> for sampling + 12.5 for successive approximation)			1/f <sub>ADC</sub>

1. Based on characterization, not tested in production.
2. Guaranteed by design, not tested in production.
3. V<sub>REF+</sub> is internally connected to V<sub>DDA</sub> and V<sub>REF-</sub> is internally connected to V<sub>SSA</sub>.
4. For external triggers, a delay of 1/f<sub>PCLK2</sub> must be added to the latency specified in [Table 52](#).

**Equation 1: R<sub>AIN</sub> max formula**

$$R_{AIN} < \frac{T_S}{f_{ADC} \times C_{ADC} \times \ln(2)} R_{ADC}$$

The formula above ([Equation 1](#)) is used to determine the maximum external impedance allowed for an error below 1/4 of LSB. Here N = 12 (from 12-bit resolution).

**Table 53. R<sub>AIN</sub> max for f<sub>ADC</sub> = 14 MHz<sup>(1)</sup>**

T <sub>s</sub> (cycles)	t <sub>s</sub> (µs)	R <sub>AIN</sub> max (kΩ)
1.5	0.11	0.4
7.5	0.54	5.9
13.5	0.96	11.4
28.5	2.04	25.2
41.5	2.96	37.2
55.5	3.96	50
71.5	5.11	NA
239.5	17.1	NA

1. Based on characterization, not tested in production.



**Table 54. ADC accuracy - limited test conditions<sup>(1)</sup>**

Symbol	Parameter	Test conditions	Typ	Max <sup>(2)</sup>	Unit
ET	Total unadjusted error	$f_{PCLK2} = 56 \text{ MHz}$ , $f_{ADC} = 14 \text{ MHz}$ , $R_{AIN} < 10 \text{ k}\Omega$ , $V_{DDA} = 3 \text{ V to } 3.6 \text{ V}$ $T_A = 25 \text{ }^\circ\text{C}$ Measurements made after ADC calibration	$\pm 1.3$	$\pm 2$	LSB
EO	Offset error		$\pm 1$	$\pm 1.5$	
EG	Gain error		$\pm 0.5$	$\pm 1.5$	
ED	Differential linearity error		$\pm 0.7$	$\pm 1$	
EL	Integral linearity error		$\pm 0.8$	$\pm 1.5$	

1. ADC DC accuracy values are measured after internal calibration.
2. Based on characterization, not tested in production.

**Table 55. ADC accuracy<sup>(1) (2)</sup>**

Symbol	Parameter	Test conditions	Typ	Max <sup>(3)</sup>	Unit
ET	Total unadjusted error	$f_{PCLK2} = 56 \text{ MHz}$ , $f_{ADC} = 14 \text{ MHz}$ , $R_{AIN} < 10 \text{ k}\Omega$ , $V_{DDA} = 2.4 \text{ V to } 3.6 \text{ V}$ Measurements made after ADC calibration	$\pm 2$	$\pm 5$	LSB
EO	Offset error		$\pm 1.5$	$\pm 2.5$	
EG	Gain error		$\pm 1.5$	$\pm 3$	
ED	Differential linearity error		$\pm 1$	$\pm 2$	
EL	Integral linearity error		$\pm 1.5$	$\pm 3$	

1. ADC DC accuracy values are measured after internal calibration.
2. Better performance could be achieved in restricted  $V_{DD}$ , frequency and temperature ranges.
3. Based on characterization, not tested in production.

**Note:** ADC accuracy vs. negative injection current: Injecting a negative current on any of the standard (non-robust) analog input pins should be avoided as this significantly reduces the accuracy of the conversion being performed on another analog input. It is recommended to add a Schottky diode (pin to ground) to standard analog pins which may potentially inject negative currents.

Any positive injection current within the limits specified for  $I_{INJ(PIN)}$  and  $\Sigma I_{INJ(PIN)}$  in [Section 5.3.12](#) does not affect the ADC accuracy.



Figure 34. ADC accuracy characteristics

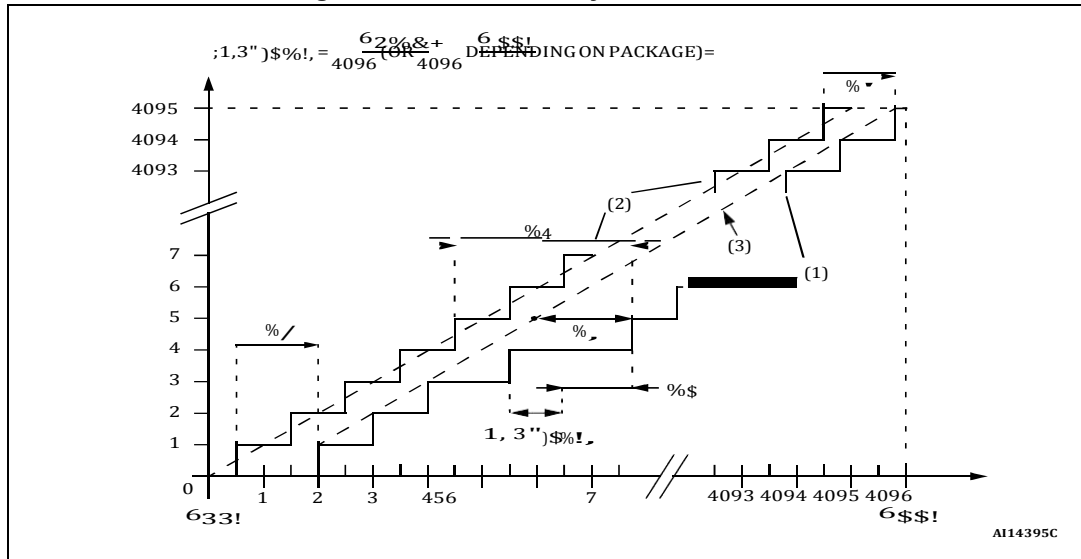
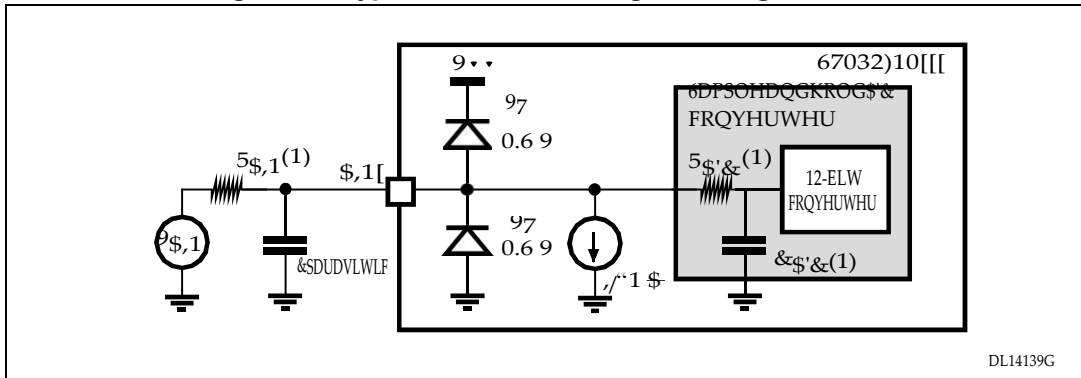


Figure 35. Typical connection diagram using the ADC



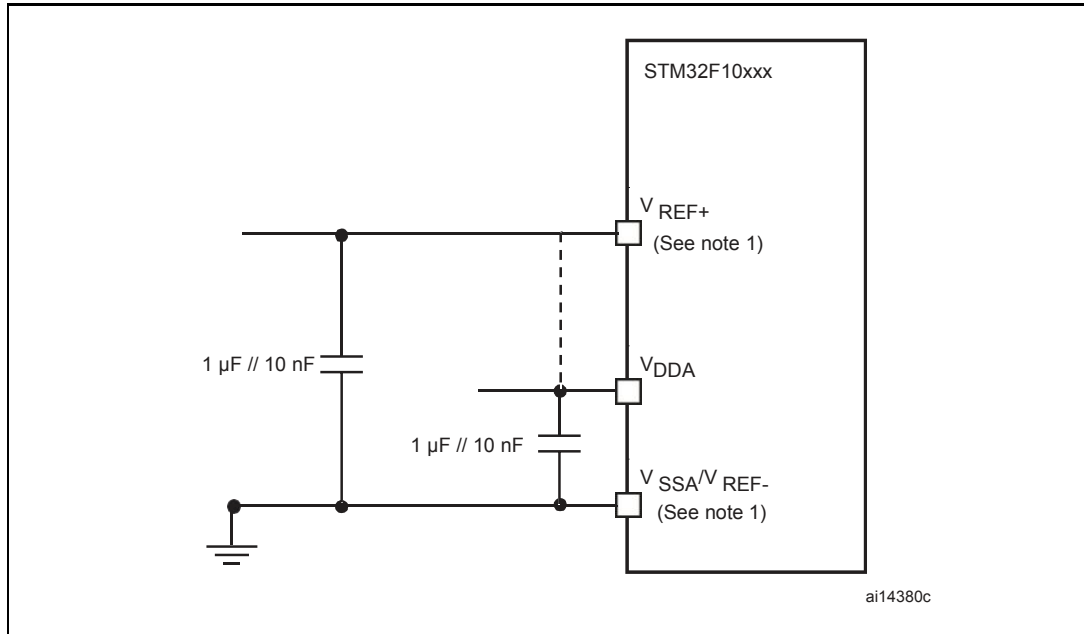
1. Refer to [Table 52](#) for the values of  $R_{AIN}$ ,  $R_{ADC}$  and  $C_{ADC}$ .
2.  $C_{parasitic}$  represents the capacitance of the PCB (dependent on soldering and PCB layout quality) plus the pad capacitance (roughly 7 pF). A high  $C_{parasitic}$  value will downgrade conversion accuracy. To remedy this,  $f_{ADC}$  should be reduced.



**General PCB design guidelines**

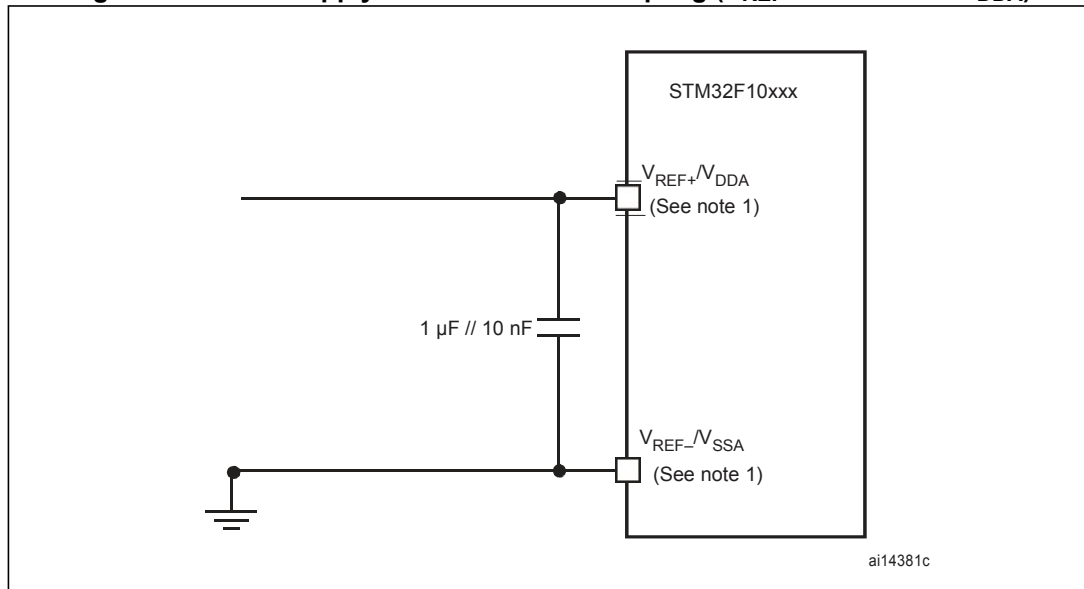
Power supply decoupling should be performed as shown in *Figure 36* or *Figure 37*, depending on whether  $V_{REF+}$  is connected to  $V_{DDA}$  or not. The 10 nF capacitors should be ceramic (good quality). They should be placed them as close as possible to the chip.

**Figure 36. Power supply and reference decoupling ( $V_{REF+}$  not connected to  $V_{DDA}$ )**



1.  $V_{REF+}$  and  $V_{REF-}$  inputs are available only on 100-pin packages.

**Figure 37. Power supply and reference decoupling ( $V_{REF+}$  connected to  $V_{DDA}$ )**



1.  $V_{REF+}$  and  $V_{REF-}$  inputs are available only on 100-pin packages.





5.3.18 DAC electrical specifications

Table 56. DAC characteristics

Symbol	Parameter	Min	Typ	Max	Unit	Comments
V <sub>DDA</sub>	Analog supply voltage	2.4	-	3.6	V	-
V <sub>REF+</sub>	Reference supply voltage	2.4	-	3.6	V	V <sub>REF+</sub> must always be below V <sub>DDA</sub>
V <sub>SSA</sub>	Ground	0	-	0	V	-
R <sub>LOAD</sub> <sup>(1)</sup>	Resistive load with buffer ON	5	-	-	k Ω	-
R <sub>O</sub> <sup>(1)</sup>	Impedance output with buffer OFF	-	-	15	k Ω	When the buffer is OFF, the Minimum resistive load between DAC_OUT and V <sub>SS</sub> to have a 1% accuracy is 1.5 M Ω
C <sub>LOAD</sub> <sup>(1)</sup>	Capacitive load	-	-	50	pF	Maximum capacitive load at DAC_OUT pin (when the buffer is ON).
DAC_OUT <sub>min</sub> <sup>(1)</sup>	Lower DAC_OUT voltage with buffer ON	0.2	-	-	V	It gives the maximum output excursion of the DAC. It corresponds to 12-bit input code (0x0E0) to (0xF1C) at V <sub>REF+</sub> = 3.6 V and (0x155) to (0xEAB) at V <sub>REF+</sub> = 2.4 V
DAC_OUT <sub>max</sub> <sup>(1)</sup>	Higher DAC_OUT voltage with buffer ON	-	-	V <sub>DDA</sub> - 0.2	V	
DAC_OUT <sub>min</sub> <sup>(1)</sup>	Lower DAC_OUT voltage with buffer OFF	-	0.5	-	mV	It gives the maximum output excursion of the DAC.
DAC_OUT <sub>max</sub> <sup>(1)</sup>	Higher DAC_OUT voltage with buffer OFF	-	-	V <sub>REF+</sub> - 1LSB	V	
I <sub>DDVREF+</sub>	DAC DC current consumption in quiescent mode (Standby mode)	-	-	220	μA	With no load, worst code (0xF1C) at V <sub>REF+</sub> = 3.6 V in terms of DC consumption on the inputs
I <sub>DDA</sub>	DAC DC current consumption in quiescent mode (Standby mode)	-	-	380	μA	With no load, middle code (0x800) on the inputs
		-	-	480	μA	With no load, worst code (0xF1C) at V <sub>REF+</sub> = 3.6 V in terms of DC consumption on the inputs
DNL <sup>(2)</sup>	Differential non linearity Difference between two consecutive code-1LSB)	-	-	±0.5	LSB	Given for the DAC in 10-bit configuration.
		-	-	±2	LSB	Given for the DAC in 12-bit configuration.
INL <sup>(2)</sup>	Integral non linearity (difference between measured value at Code i and the value at Code i on a line drawn between Code 0 and last Code 1023)	-	-	±1	LSB	Given for the DAC in 10-bit configuration.
		-	-	±4	LSB	Given for the DAC in 12-bit configuration.

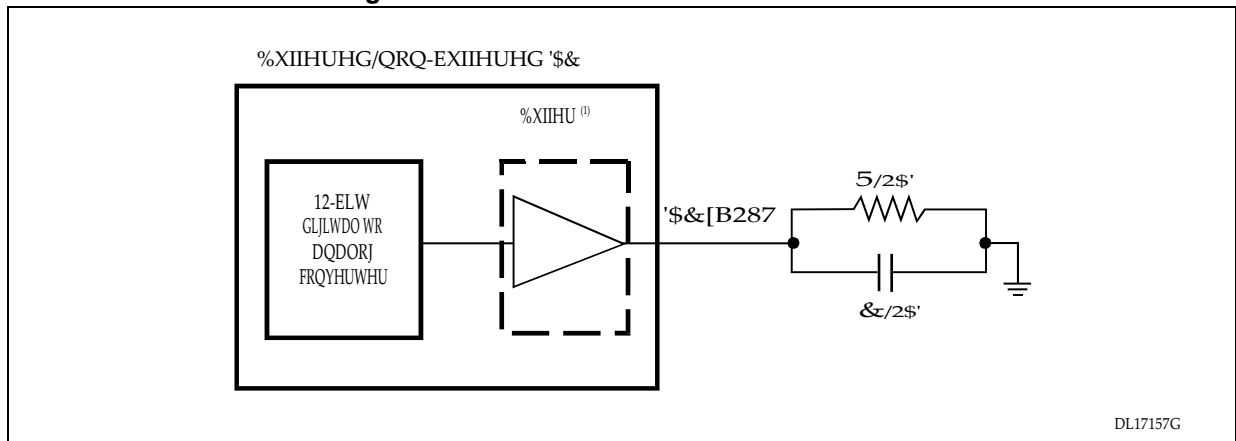


Table 56. DAC characteristics (continued)

Symbol	Parameter	Min	Typ	Max	Unit	Comments
Offset <sup>(2)</sup>	Offset error (difference between measured value at Code (0x800) and the ideal value = $V_{REF+}/2$ )	-	-	±10	mV	Given for the DAC in 12-bit configuration
		-	-	±3	LSB	Given for the DAC in 10-bit at $V_{REF+} = 3.6\text{ V}$
		-	-	±12	LSB	Given for the DAC in 12-bit at $V_{REF+} = 3.6\text{ V}$
Gain error <sup>(2)</sup>	Gain error	-	-	±0.5	%	Given for the DAC in 12bit configuration
$t_{SETTLING}^{(2)}$	Settling time (full scale: for a 10-bit input code transition between the lowest and the highest input codes when DAC_OUT reaches final value ±1LSB)	-	3	4	µs	$C_{LOAD} \leq 50\text{ pF}$ , $R_{LOAD} \geq 5\text{ k}\Omega$
Update rate <sup>(2)</sup>	Max frequency for a correct DAC_OUT change when small variation in the input code (from code i to i+1LSB)	-	-	1	MS/s	$C_{LOAD} \leq 50\text{ pF}$ , $R_{LOAD} \geq 5\text{ k}\Omega$
$t_{WAKEUP}^{(2)}$ <sub>P</sub>	Wakeup time from off state (Setting the ENx bit in the DAC Control register)	-	6.5	10	µs	$C_{LOAD} \leq 50\text{ pF}$ , $R_{LOAD} \geq 5\text{ k}\Omega$ input code between lowest and highest possible ones.
PSRR+ <sup>(1)</sup>	Power supply rejection ratio (to $V_{DDA}$ ) (static DC measurement)	-	-67	-40	dB	No $R_{LOAD}$ . $C_{LOAD} = 50\text{ pF}$

1. Guaranteed by design, not tested in production.
2. Guaranteed by characterization, not tested in production.

Figure 38. 12-bit buffered /non-buffered DAC



1. The DAC integrates an output buffer that can be used to reduce the output impedance and to drive external loads directly without the use of an external operational amplifier. The buffer can be bypassed by configuring the BOFFx bit in the DAC\_CR register.



## 5.3.19 Temperature sensor characteristics

Table 57. TS characteristics

Symbol	Parameter	Min	Typ	Max	Unit
$T_L^{(1)}$	V <sub>SENSE</sub> linearity with temperature	-	±1	±2	°C
Avg_Slope <sup>(1)</sup>	Average slope	4.0	4.3	4.6	mV/°C
$V_{25}^{(1)}$	Voltage at 25 °C	1.34	1.43	1.52	V
$t_{START}^{(2)}$	Startup time	4	-	10	µs
$T_{S\_temp}^{(3)(2)}$	ADC sampling time when reading the temperature	-	-	17.1	µs

1. Based on characterization, not tested in production.
2. Guaranteed by design, not tested in production.
3. Shortest sampling time can be determined in the application by multiple iterations.

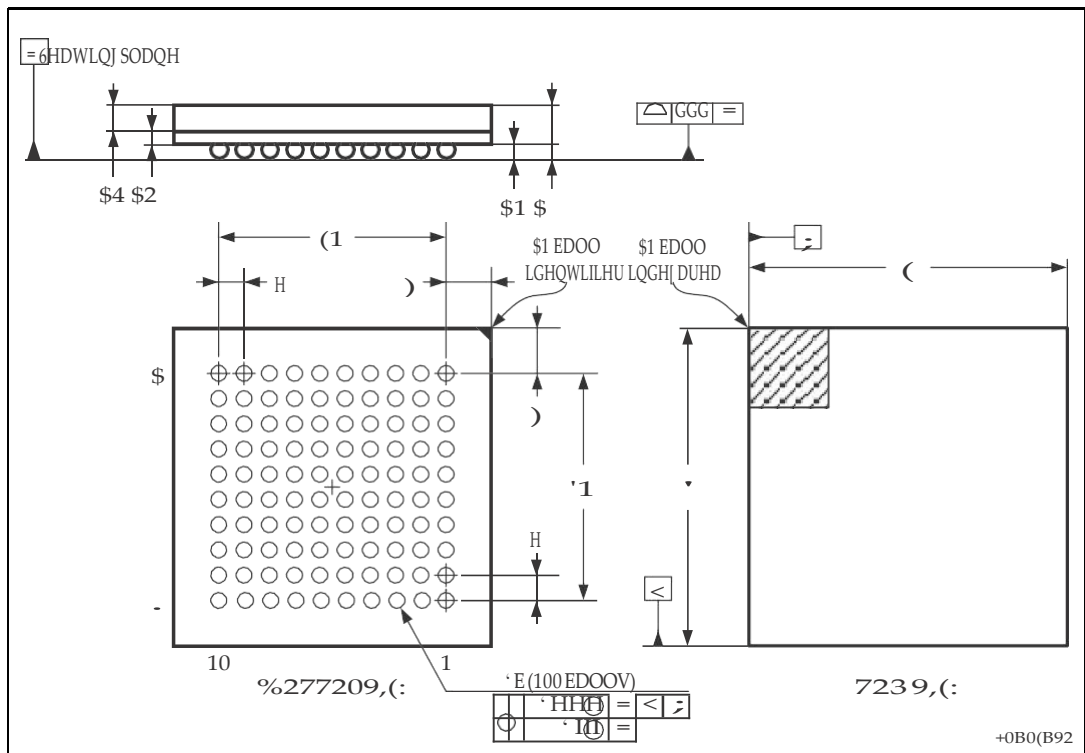


## 6 Package information

In order to meet environmental requirements, ST offers these devices in different grades of ECOPACK® packages, depending on their level of environmental compliance. ECOPACK® specifications, grade definitions and product status are available at: [www.st.com](http://www.st.com). ECOPACK® is an ST trademark.

### 6.1 LFBGA100 package information

Figure 39. LFBGA100 - 10 x 10 mm low profile fine pitch ball grid array package outline





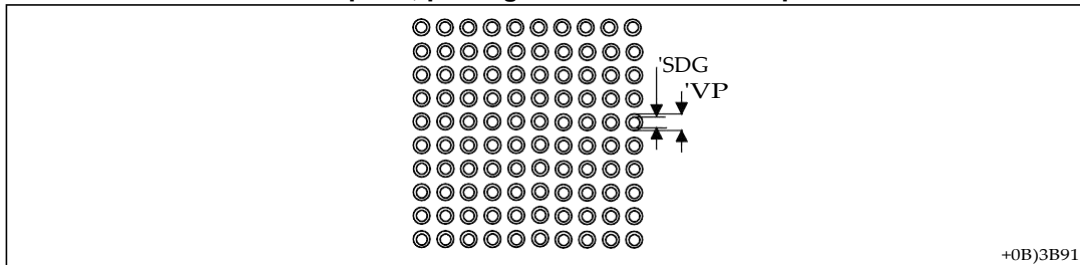


**Figure 40. LFBGA100 – 100-ball low profile fine pitch ball grid array, 10 x 10 mm, 0.8 mm pitch, package mechanical data**

Symbol	millimeters			inches <sup>(1)</sup>		
	Min	Typ	Max	Typ	Min	Max
A	-	-	1.700	-	-	0.0669
A1	0.270	-	-	0.0106	-	-
A2	-	0.300	-	-	0.0118	-
A4	-	-	0.800	-	-	0.0315
b	0.450	0.500	0.550	0.0177	0.0197	0.0217
D	9.850	10.000	10.150	0.3878	0.3937	0.3996
D1	-	7.200	-	-	0.2835	-
E	9.850	10.000	10.150	0.3878	0.3937	0.3996
E1	-	7.200	-	-	0.2835	-
e	-	0.800	-	-	0.0315	-
F	-	1.400	-	-	0.0551	-
ddd	-	-	0.120	-	-	0.0047
eee	-	-	0.150	-	-	0.0059
fff	-	-	0.080	-	-	0.0031

1. Values in inches are converted from mm and rounded to 4 decimal digits.

**Figure 41. LFBGA100 – 100-ball low profile fine pitch ball grid array, 10 x 10 mm, 0.8 mm pitch, package recommended footprint**



**Table 58. LFBGA100 recommended PCB design rules (0.8 mm pitch BGA)**

Dimension	Recommended values
Pitch	0.8
Dpad	0.500 mm
Dsm	0.570 mm typ. (depends on the soldermask registration tolerance)
Stencil opening	0.500 mm
Stencil thickness	Between 0.100 mm and 0.125 mm
Pad trace width	0.120 mm

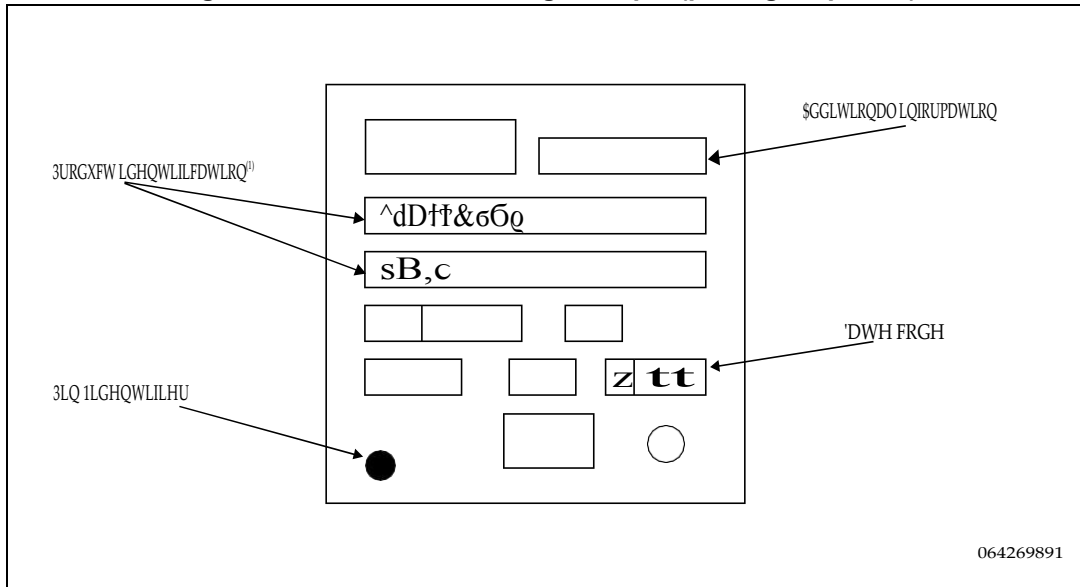


### Device marking for LFBGA100

The following figure shows the device marking for the LQFP100 package.

Other optional marking or inset/upset marks, which identify the parts throughout supply chain operations, are not indicated below.

Figure 42. LFBGA100 marking example (package top view)

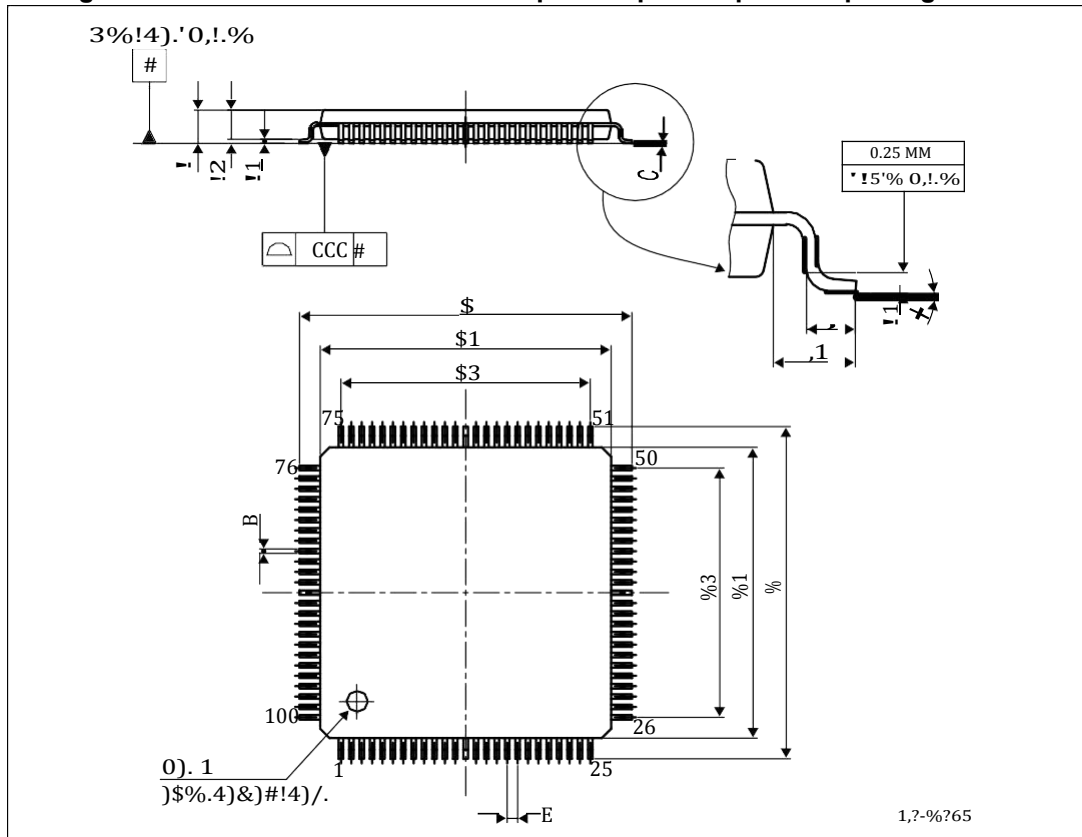


Parts marked as “ES”, “E” or accompanied by an Engineering Sample notification letter, are not yet qualified and therefore not yet ready to be used in production and any consequences deriving from such usage will not be at ST charge. In no event, ST will be liable for any customer usage of these engineering samples in production. ST Quality has to be contacted prior to any decision to use these Engineering samples to run qualification activity.



## 6.2 LQFP100 package information

Figure 43. LQFP100 – 14 x 14 mm 100 pin low-profile quad flat package outline



1. Drawing is not to scale. Dimension are in millimeter.

Table 59. LQFP100 - 100-pin, 14 x 14 mm low-profile quad flat package mechanical data

Symbol	millimeters			inches <sup>(1)</sup>		
	Min	Typ	Max	Min	Typ	Max
A	-	-	1.600	-	-	0.0630
A1	0.050	-	0.150	0.0020	-	0.0059
A2	1.350	1.400	1.450	0.0531	0.0551	0.0571
b	0.170	0.220	0.270	0.0067	0.0087	0.0106
c	0.090	-	0.200	0.0035	-	0.0079
D	15.800	16.000	16.200	0.6220	0.6299	0.6378
D1	13.800	14.000	14.200	0.5433	0.5512	0.5591
D3	-	12.000	-	-	0.4724	-
E	15.800	16.000	16.200	0.6220	0.6299	0.6378
E1	13.800	14.000	14.200	0.5433	0.5512	0.5591

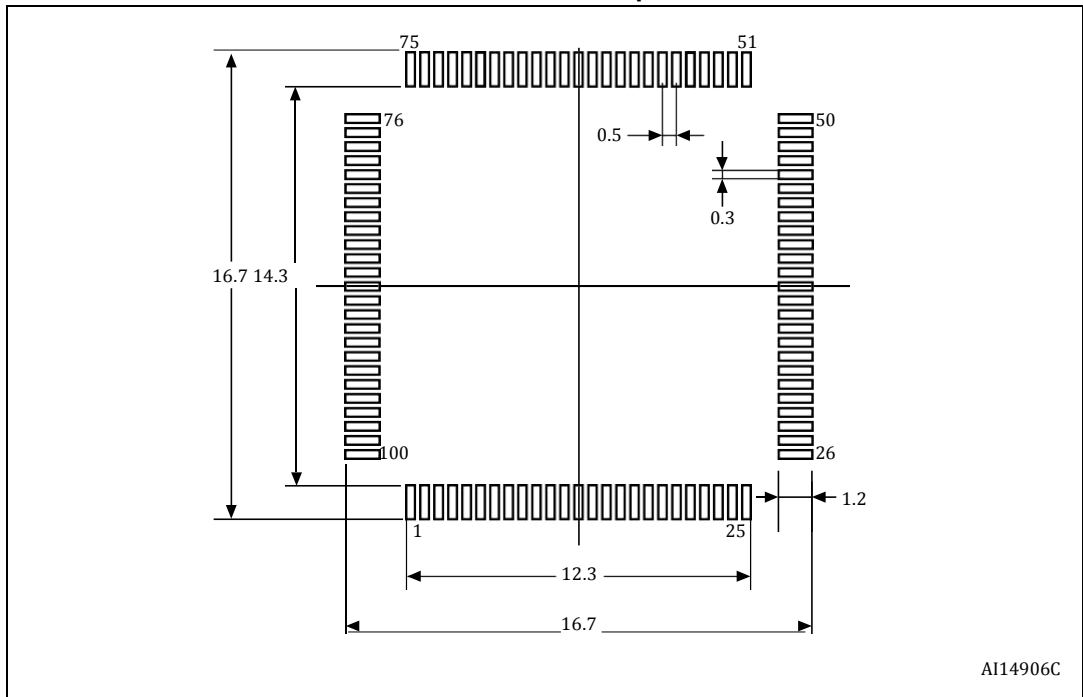


**Table 59. LQPF100 - 100-pin, 14 x 14 mm low-profile quad flat package mechanical data (continued)**

Symbol	millimeters			inches <sup>(1)</sup>		
	Min	Typ	Max	Min	Typ	Max
E3	-	12.000	-	-	0.4724	-
e	-	0.500	-	-	0.0197	-
L	0.450	0.600	0.750	0.0177	0.0236	0.0295
L1	-	1.000	-	-	0.0394	-
k	0.0°	3.5°	7.0°	0.0°	3.5°	7.0°
ccc	-	-	0.080	-	-	0.0031

1. Values in inches are converted from mm and rounded to 4 decimal digits.

**Figure 44. LQFP100 - 100-pin, 14 x 14 mm low-profile quad flat recommended footprint**



A114906C



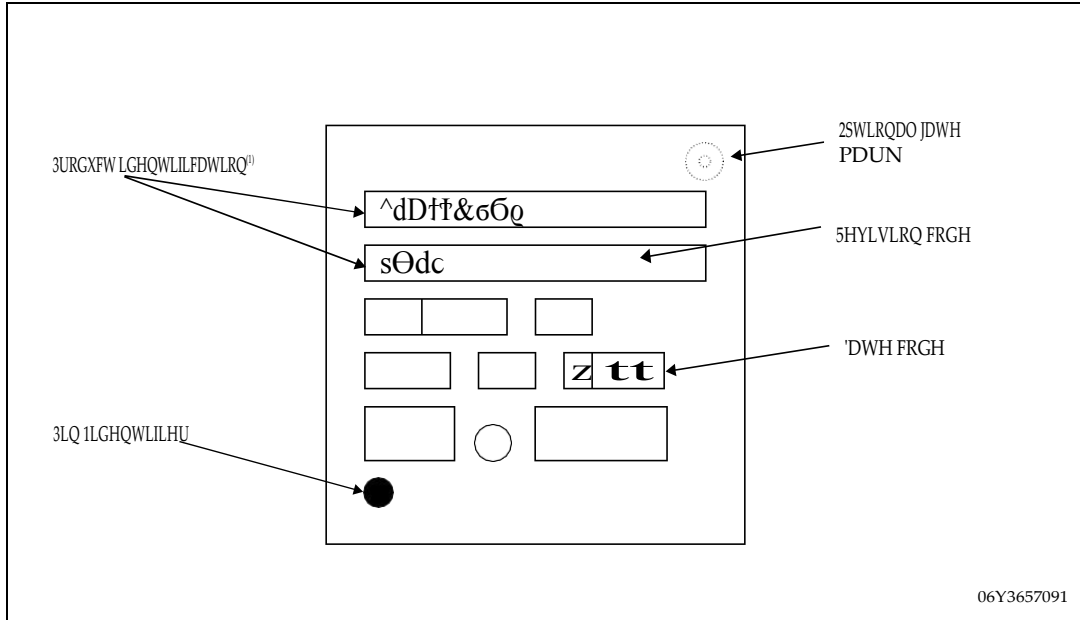


**Device marking for LQFP100**

The following figure shows the device marking for the LQFP100 package.

Other optional marking or inset/upset marks, which identify the parts throughout supply chain operations, are not indicated below.

**Figure 45.LQFP100 marking example (package top view)**

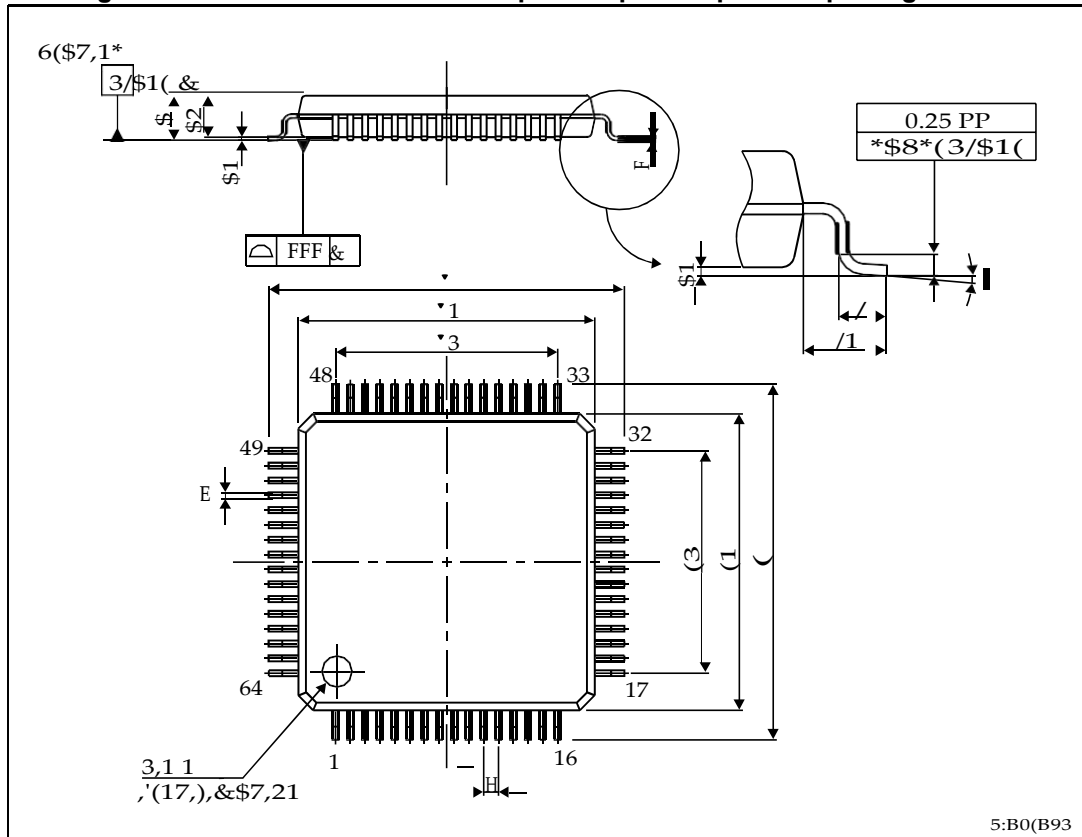


1. Parts marked as “ES”, “E” or accompanied by an Engineering Sample notification letter, are not yet qualified and therefore not yet ready to be used in production and any consequences deriving from such usage will not be at ST charge. In no event, ST will be liable for any customer usage of these engineering samples in production. ST Quality has to be contacted prior to any decision to use these Engineering samples to run qualification activity.



### 6.3 LQFP64 package information

Figure 46.LQFP64 – 10 x 10 mm 64 pin low-profile quad flat package outline



1. Drawing is not in scale.

Table 60.LQFP64 – 10 x 10 mm 64 pin low-profile quad flat package mechanical data

Symbol	millimeters			inches <sup>(1)</sup>		
	Min	Typ	Max	Min	Typ	Max
A	-	-	1.600	-	-	0.0630
A1	0.050	-	0.150	0.0020	-	0.0059
A2	1.350	1.400	1.450	0.0531	0.0551	0.0571
b	0.170	0.220	0.270	0.0067	0.0087	0.0106
c	0.090	-	0.200	0.0035	-	0.0079
D	-	12.000	-	-	0.4724	-
D1	-	10.000	-	-	0.3937	-
D3	-	7.500	-	-	0.2953	-
E	-	12.000	-	-	0.4724	-
E1	-	10.000	-	-	0.3937	-
E3	-	7.500	-	-	0.2953	-

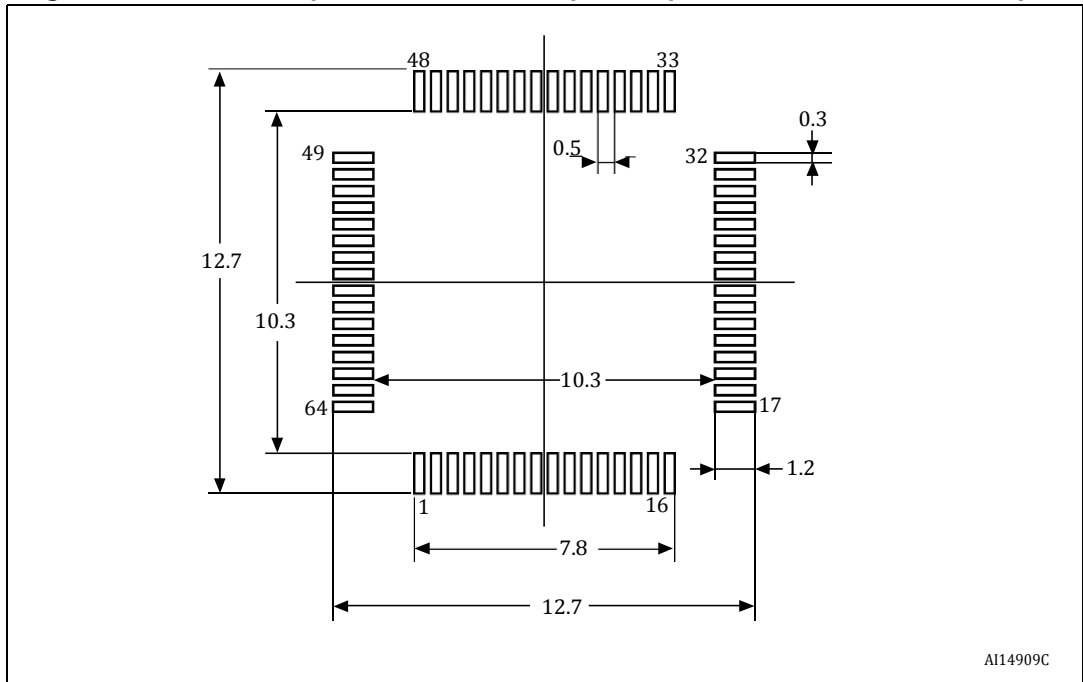


Table 60.LQFP64 – 10 x 10 mm 64 pin low-profile quad flat package mechanical data

Symbol	millimeters			inches <sup>(1)</sup>		
	Min	Typ	Max	Min	Typ	Max
e	-	0.500	-	-	0.0197	-
θ	0°	3.5°	7°	0°	3.5°	7°
L	0.450	0.600	0.750	0.0177	0.0236	0.0295
L1	-	1.000	-	-	0.0394	-
ccc	-	-	0.080	-	-	0.0031

1. Values in inches are converted from mm and rounded to 4 decimal digits.

Figure 47.LQFP64 - 64-pin, 10 x 10 mm low-profile quad flat recommended footprint



1. Dimensions are in millimeters.

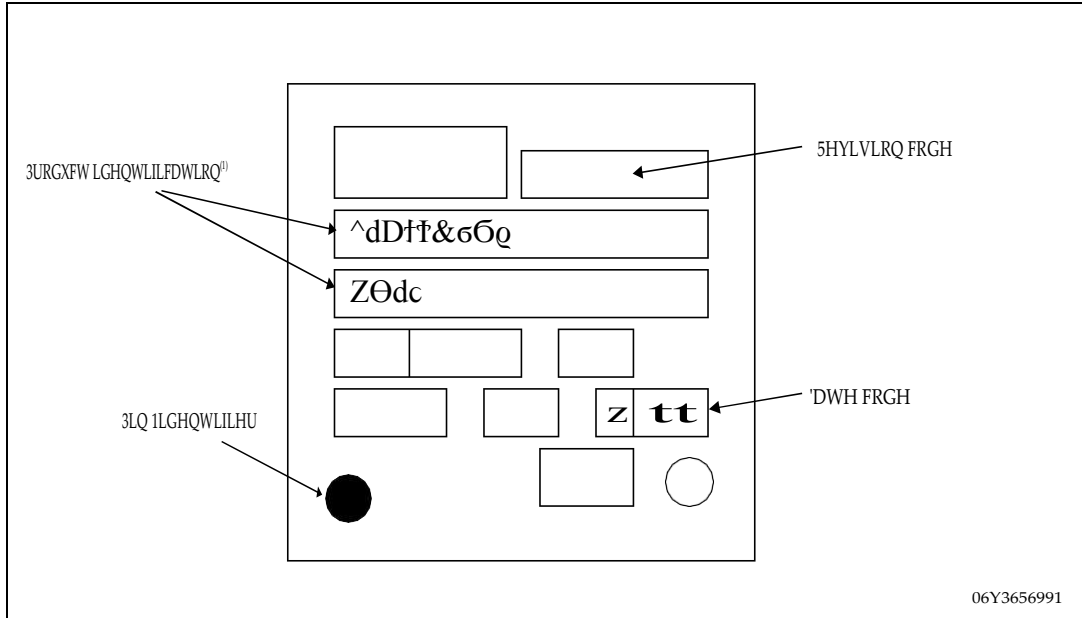


**Device marking for LQFP64**

The following figure shows the device marking for the LQFP64 package.

Other optional marking or inset/upset marks, which identify the parts throughout supply chain operations, are not indicated below.

**Figure 48.LQFP64 marking example (package top view)**



1. Parts marked as “ES”, “E” or accompanied by an Engineering Sample notification letter, are not yet qualified and therefore not yet ready to be used in production and any consequences deriving from such usage will not be at ST charge. In no event, ST will be liable for any customer usage of these engineering samples in production. ST Quality has to be contacted prior to any decision to use these Engineering samples to run qualification activity.





## 6.4 Thermal characteristics

The maximum chip junction temperature ( $T_{Jmax}$ ) must never exceed the values given in [Table 9: General operating conditions on page 37](#).

The maximum chip-junction temperature,  $T_{Jmax}$ , in degrees Celsius, may be calculated using the following equation:

$$T_{Jmax} = T_{Amax} + (P_{Dmax} \times \Theta_{JA})$$

Where:

- $T_{Amax}$  is the maximum ambient temperature in °C,
- $\Theta_{JA}$  is the package junction-to-ambient thermal resistance, in °C/W,
- $P_{Dmax}$  is the sum of  $P_{INTmax}$  and  $P_{I/Omax}$  ( $P_{Dmax} = P_{INTmax} + P_{I/Omax}$ ),
- $P_{INTmax}$  is the product of  $I_{DD}$  and  $V_{DD}$ , expressed in Watts. This is the maximum chip internal power.

$P_{I/Omax}$  represents the maximum power dissipation on output pins where:

$$P_{I/Omax} = \Sigma (V_{OL} \times I_{OL}) + \Sigma ((V_{DD} - V_{OH}) \times I_{OH}),$$

taking into account the actual  $V_{OL} / I_{OL}$  and  $V_{OH} / I_{OH}$  of the I/Os at low and high level in the application.

**Table 61. Package thermal characteristics**

Symbol	Parameter	Value	Unit
$\Theta_{JA}$	<b>Thermal resistance junction-ambient</b> LQFP100 - 14 × 14 mm / 0.5 mm pitch	46	°C/W
	<b>Thermal resistance junction-ambient</b> LQFP64 - 10 × 10 mm / 0.5 mm pitch	45	
$\Theta_{JA}$	<b>Thermal resistance junction-ambient</b> LFBGA100 - 10 × 10 mm / 0.8 mm pitch	40	°C/W
	<b>Thermal resistance junction-ambient</b> LQFP100 - 14 × 14 mm / 0.5 mm pitch	46	
	<b>Thermal resistance junction-ambient</b> LQFP64 - 10 × 10 mm / 0.5 mm pitch	45	

### 6.4.1 Reference document

JESD51-2 Integrated Circuits Thermal Test Method Environment Conditions - Natural Convection (Still Air). Available from [www.jedec.org](http://www.jedec.org).



## 6.4.2 Selecting the product temperature range

When ordering the microcontroller, the temperature range is specified in the ordering information scheme shown in [Table 62: Ordering information scheme](#).

Each temperature range suffix corresponds to a specific guaranteed ambient temperature at maximum dissipation and, to a specific maximum junction temperature.

As applications do not commonly use the STM32F103xx at maximum dissipation, it is useful to calculate the exact power consumption and junction temperature to determine which temperature range will be best suited to the application.

The following examples show how to calculate the temperature range needed for a given application.

### Example 1: High-performance application

Assuming the following application conditions:

Maximum ambient temperature  $T_{Amax} = 82\text{ °C}$  (measured according to JESD51-2),  
 $I_{DDmax} = 50\text{ mA}$ ,  $V_{DD} = 3.5\text{ V}$ , maximum 20 I/Os used at the same time in output at low level with  $I_{OL} = 8\text{ mA}$ ,  $V_{OL} = 0.4\text{ V}$  and maximum 8 I/Os used at the same time in output at low level with  $I_{OL} = 20\text{ mA}$ ,  $V_{OL} = 1.3\text{ V}$

$$P_{INTmax} = 50\text{ mA} \times 3.5\text{ V} = 175\text{ mW}$$

$$P_{IOmax} = 20 \times 8\text{ mA} \times 0.4\text{ V} + 8 \times 20\text{ mA} \times 1.3\text{ V} = 272\text{ mW}$$

This gives:  $P_{INTmax} = 175\text{ mW}$  and  $P_{IOmax} = 272\text{ mW}$ :

$$P_{Dmax} = 175 + 272 = 447\text{ mW}$$

Thus:  $P_{Dmax} = 447\text{ mW}$

Using the values obtained in [Table 61](#)  $T_{Jmax}$  is calculated as follows:

– For LQFP100,  $46\text{ °C/W}$

$$T_{Jmax} = 82\text{ °C} + (46\text{ °C/W} \times 447\text{ mW}) = 82\text{ °C} + 20.6\text{ °C} = 102.6\text{ °C}$$

This is within the range of the suffix 6 version parts ( $-40 < T_J < 105\text{ °C}$ ).

In this case, parts must be ordered at least with the temperature range suffix 6 (see [Table 62: Ordering information scheme](#)).

### Example 2: High-temperature application

Using the same rules, it is possible to address applications that run at high ambient temperatures with a low dissipation, as long as junction temperature  $T_J$  remains within the specified range.

Assuming the following application conditions:

Maximum ambient temperature  $T_{Amax} = 115\text{ °C}$  (measured according to JESD51-2),  
 $I_{DDmax} = 20\text{ mA}$ ,  $V_{DD} = 3.5\text{ V}$ , maximum 20 I/Os used at the same time in output at low level with  $I_{OL} = 8\text{ mA}$ ,  $V_{OL} = 0.4\text{ V}$

$$P_{INTmax} = 20\text{ mA} \times 3.5\text{ V} = 70\text{ mW}$$

$$P_{IOmax} = 20 \times 8\text{ mA} \times 0.4\text{ V} = 64\text{ mW}$$

This gives:  $P_{INTmax} = 70\text{ mW}$  and  $P_{IOmax} = 64\text{ mW}$ :

$$P_{Dmax} = 70 + 64 = 134\text{ mW}$$

Thus:  $P_{Dmax} = 134\text{ mW}$

Using the values obtained in [Table 61](#)  $T_{Jmax}$  is calculated as follows:

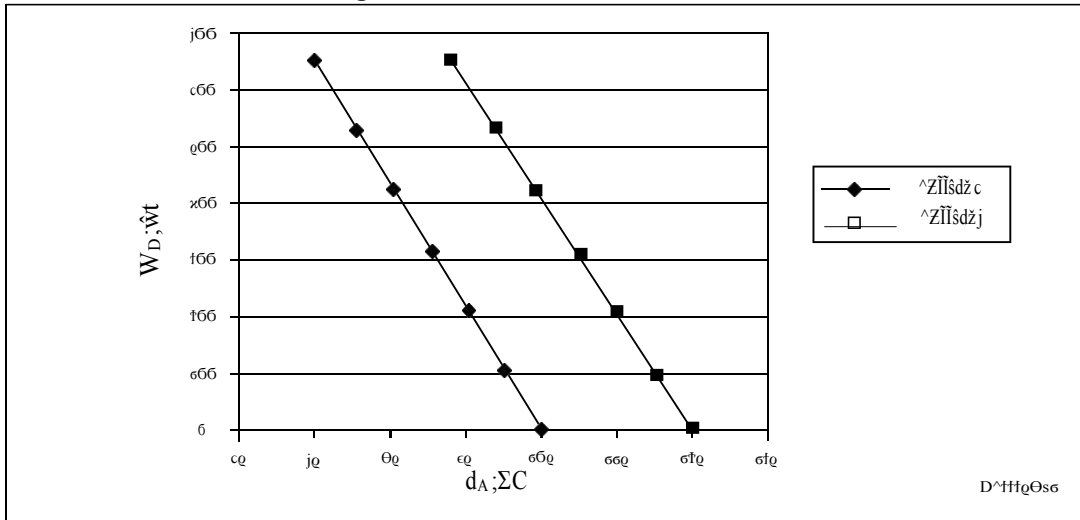
– For LQFP100, 46 °C/W

$$T_{Jmax} = 115\text{ °C} + (46\text{ °C/W} \times 134\text{ mW}) = 115\text{ °C} + 6.2\text{ °C} = 121.2\text{ °C}$$

This is within the range of the suffix 7 version parts ( $-40 < T_J < 125\text{ °C}$ ).

In this case, parts must be ordered at least with the temperature range suffix 7 (see [Table 62: Ordering information scheme](#)).

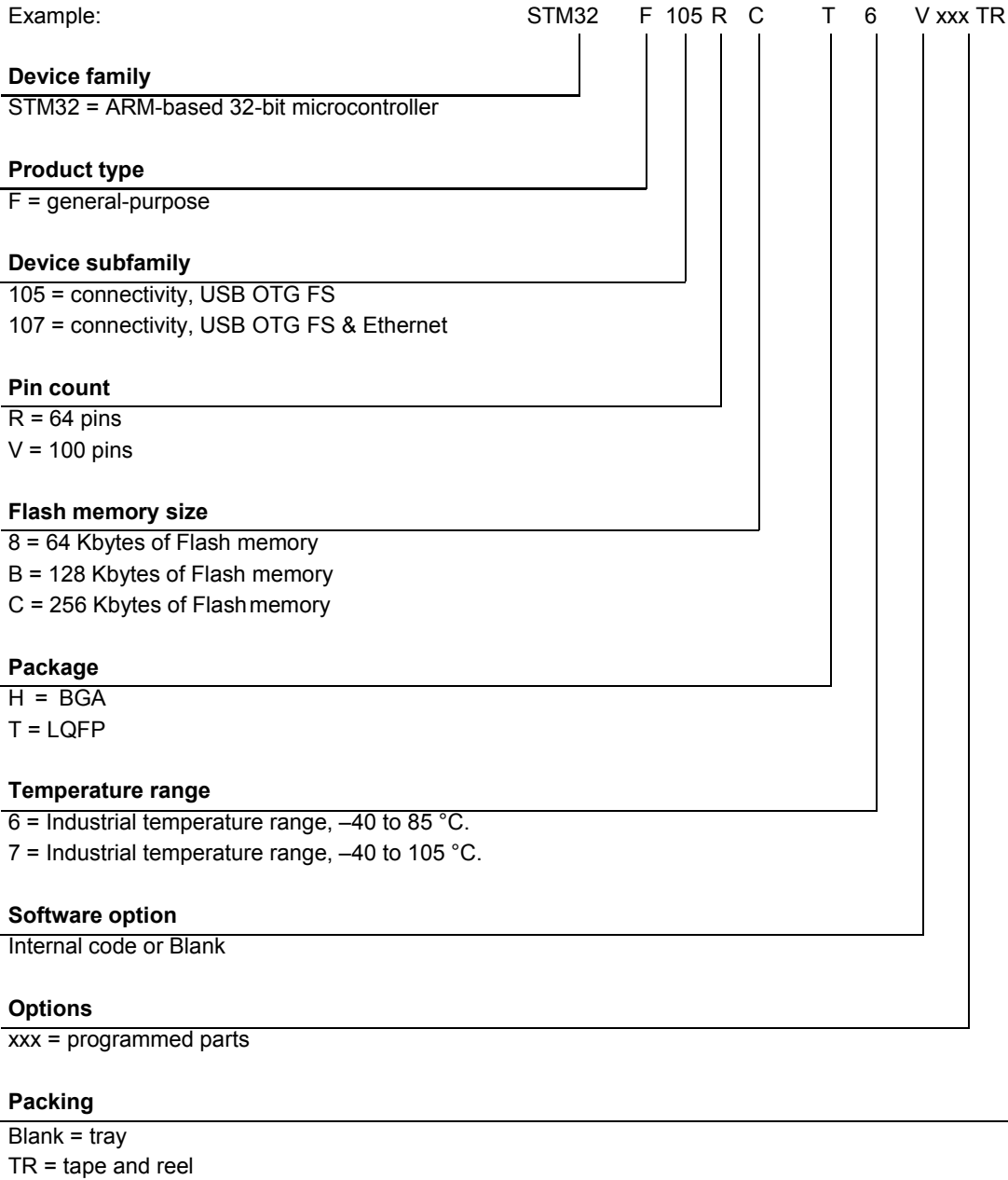
Figure 49. LQFP100  $P_D$  max vs.  $T_A$





# 7 Part numbering

**Table 62. Ordering information scheme**



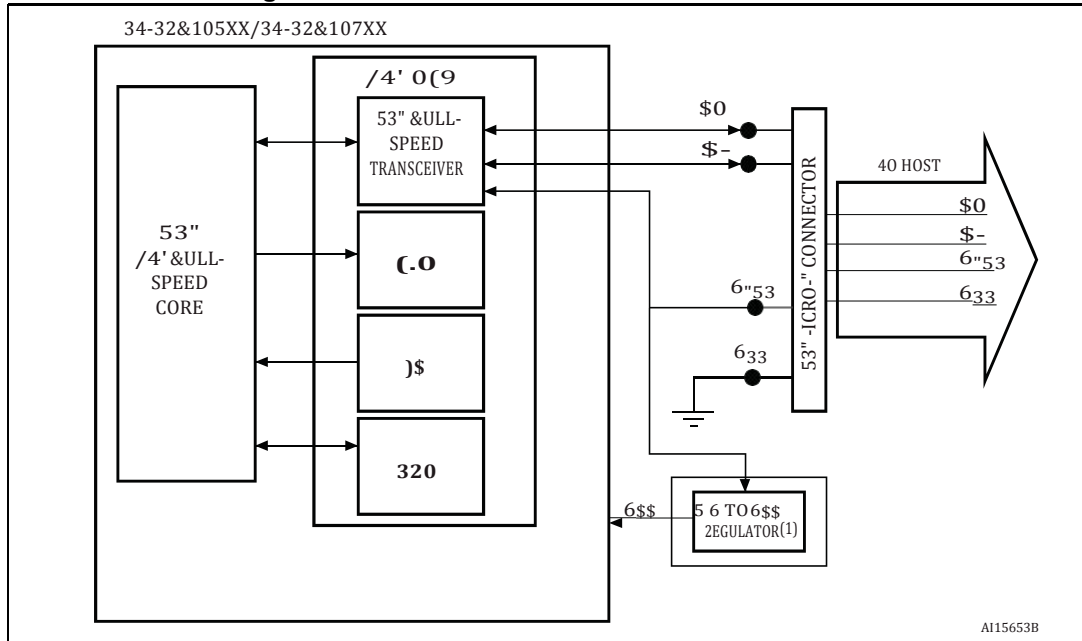
For a list of available options (speed, package, etc.) or for further information on any aspect of this device, contact your nearest ST sales office.



# Appendix A Application block diagrams

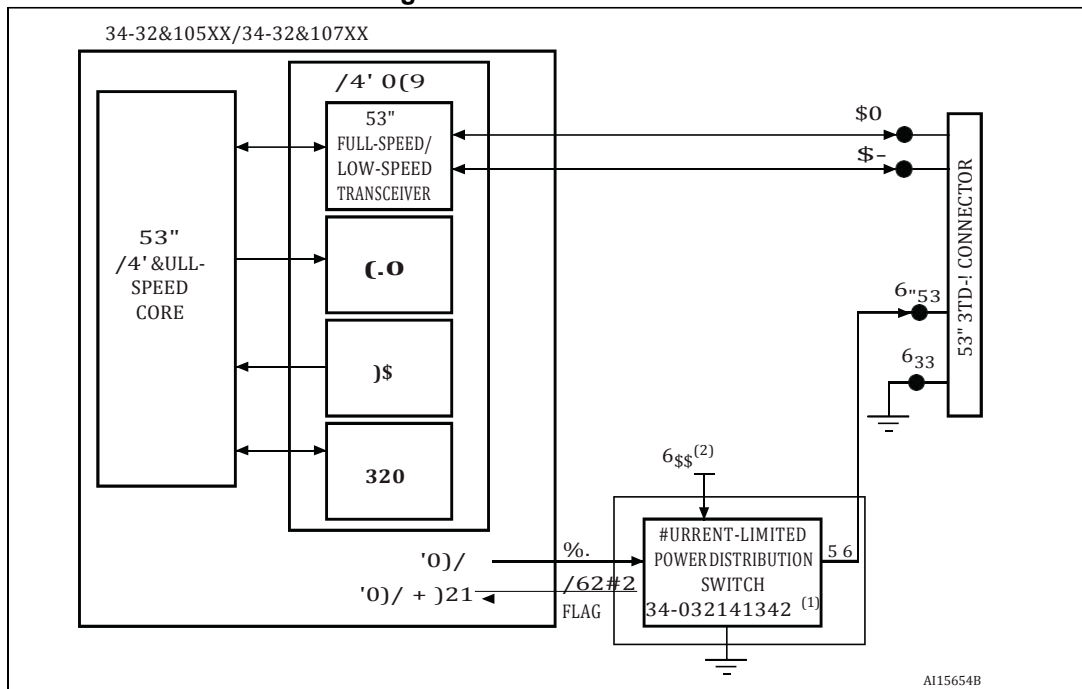
## A.1 USB OTG FS interface solutions

Figure 50. USB OTG FS device mode



1. Use a regulator if you want to build a bus-powered device.

Figure 51. Host connection

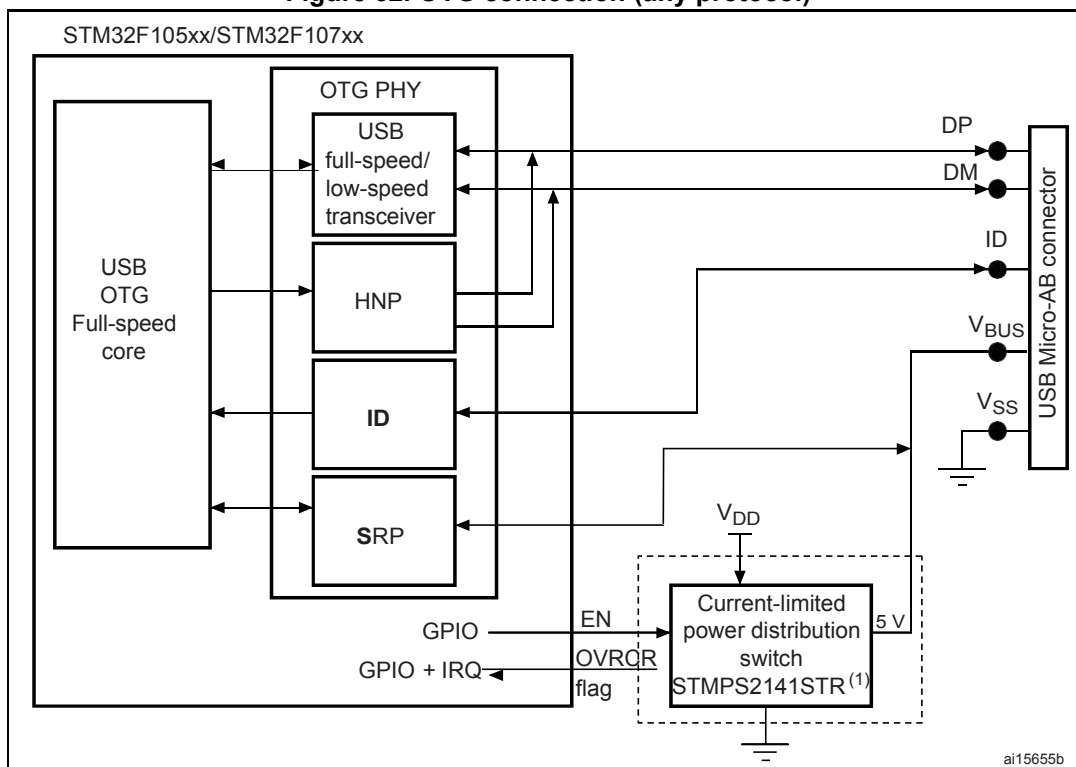


1. STMP2141STR needed only if the application has to support bus-powered devices.





Figure 52. OTG connection (any protocol)

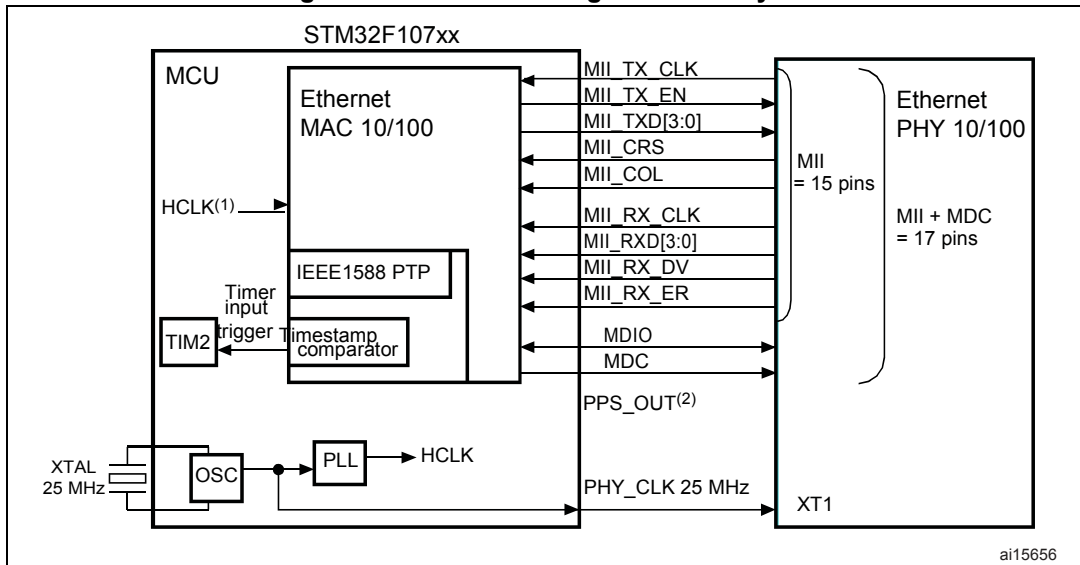


1. STMP2141STR needed only if the application has to support bus-powered devices.



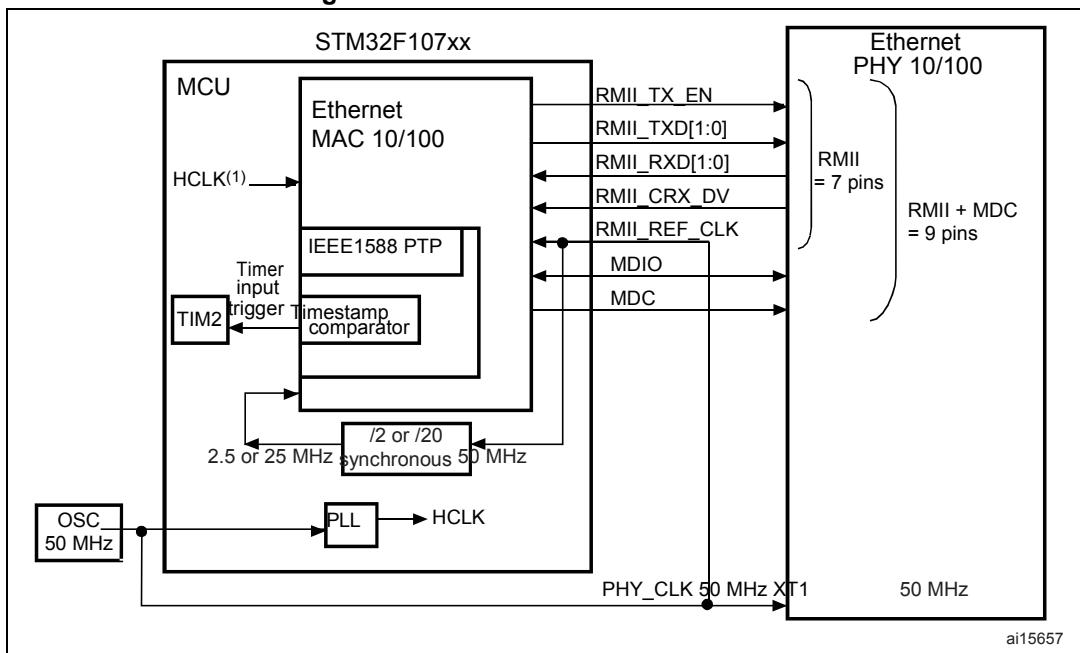
## A.2 Ethernet interface solutions

Figure 53. MII mode using a 25 MHz crystal



1. HCLK must be greater than 25 MHz.
2. Pulse per second when using IEEE1588 PTP, optional signal.

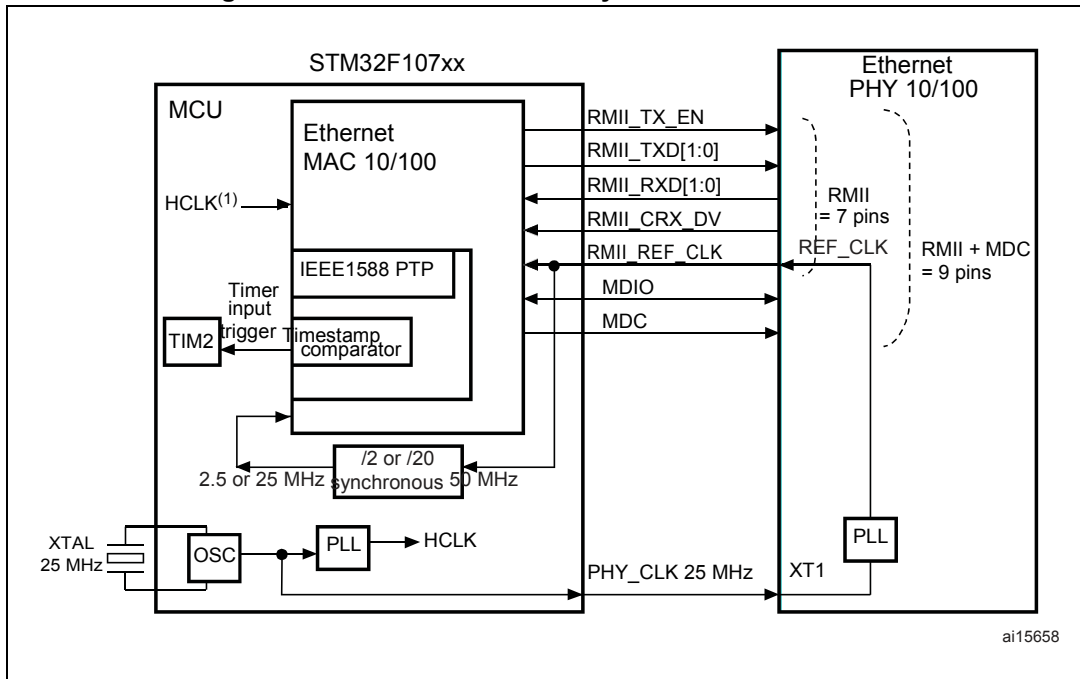
Figure 54. RMIi with a 50 MHz oscillator



1. HCLK must be greater than 25 MHz.

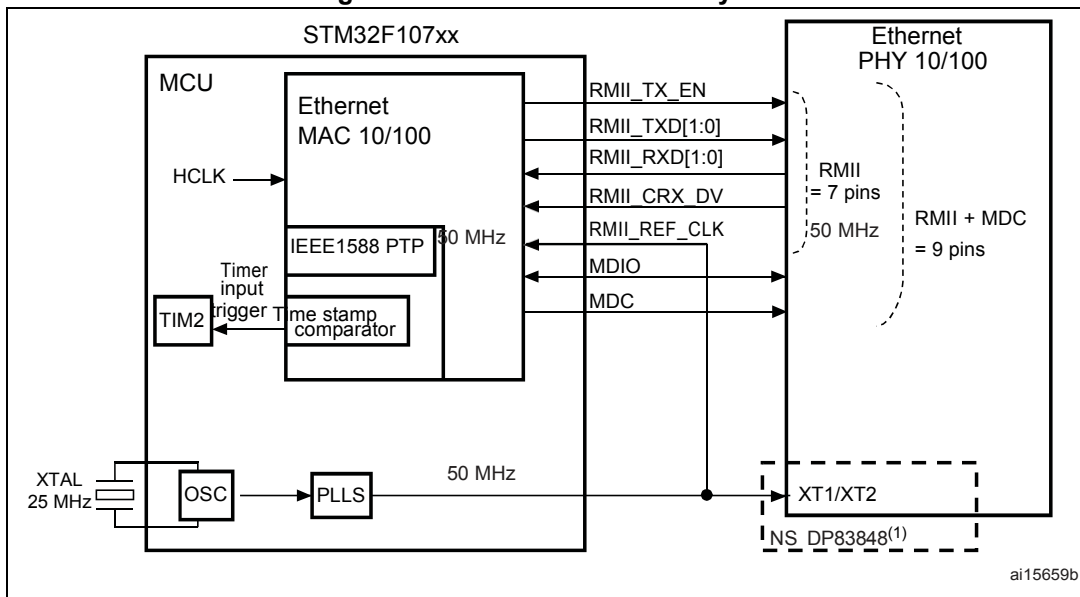


Figure 55. RMII with a 25 MHz crystal and PHY with PLL



1. HCLK must be greater than 25 MHz.

Figure 56. RMII with a 25 MHz crystal



1. The NS DP83848 is recommended as the input jitter requirement of this PHY. It is compliant with the output jitter specification of the MCU.

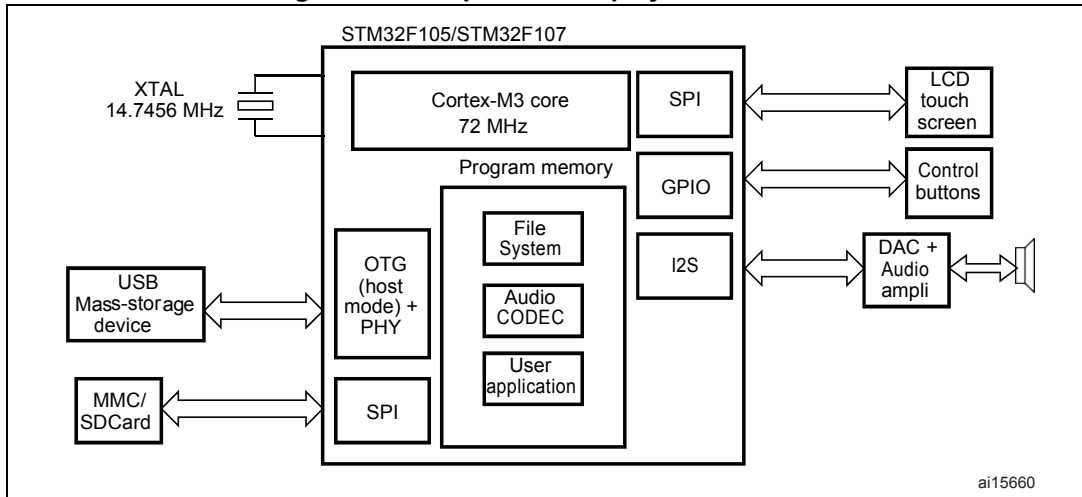


### A.3 Complete audio player solutions

Two solutions are offered, illustrated in *Figure 57* and *Figure 58*.

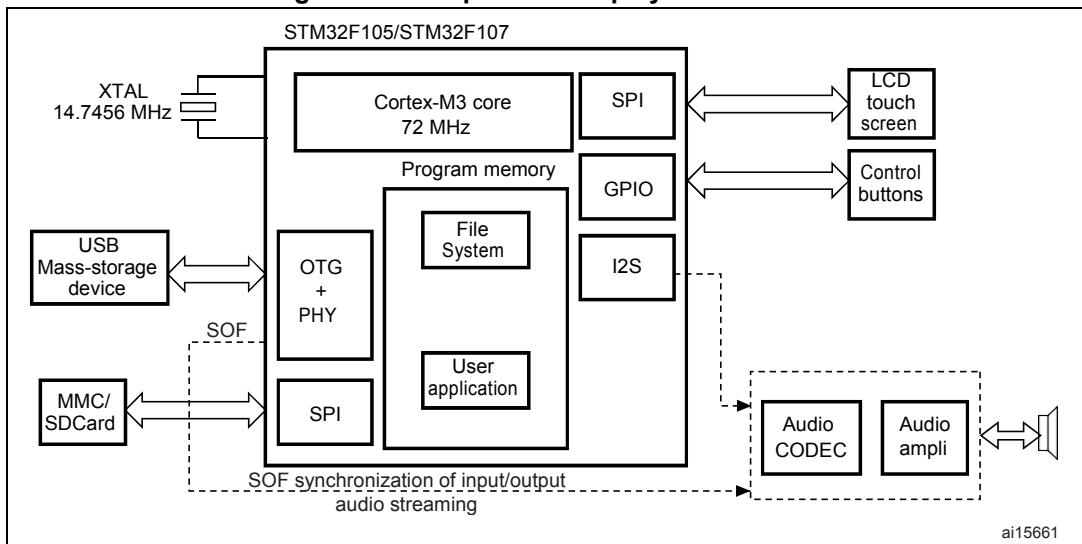
*Figure 57* shows storage media to audio DAC/amplifier streaming using a software Codec. This solution implements an audio crystal to provide audio class I<sup>2</sup>S accuracy on the master clock (0.5% error maximum, see the Serial peripheral interface section in the reference manual for details).

**Figure 57. Complete audio player solution 1**



*Figure 58* shows storage media to audio Codec/amplifier streaming with SOF synchronization of input/output audio streaming using a hardware Codec.

**Figure 58. Complete audio player solution 2**



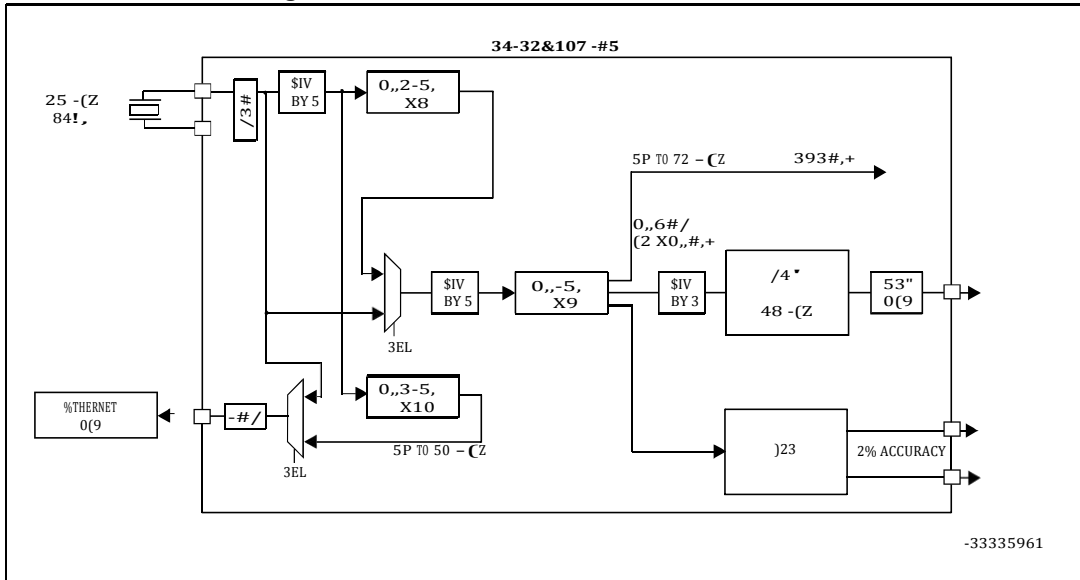




### A.4 USB OTG FS interface + Ethernet/I<sup>2</sup>S interface solutions

With the clock tree implemented on the STM32F107xx, only one crystal is required to work with both the USB (host/device/OTG) and the Ethernet (MII/RMII) interfaces. [Figure 59](#) illustrate the solution.

**Figure 59. USB O44TG FS + Ethernet solution**



With the clock tree implemented on the STM32F107xx, only one crystal is required to work with both the USB (host/device/OTG) and the I<sup>2</sup>S (Audio) interfaces. [Figure 60](#) illustrate the solution.

**Figure 60. USB OTG FS + I<sup>2</sup>S (Audio) solution**

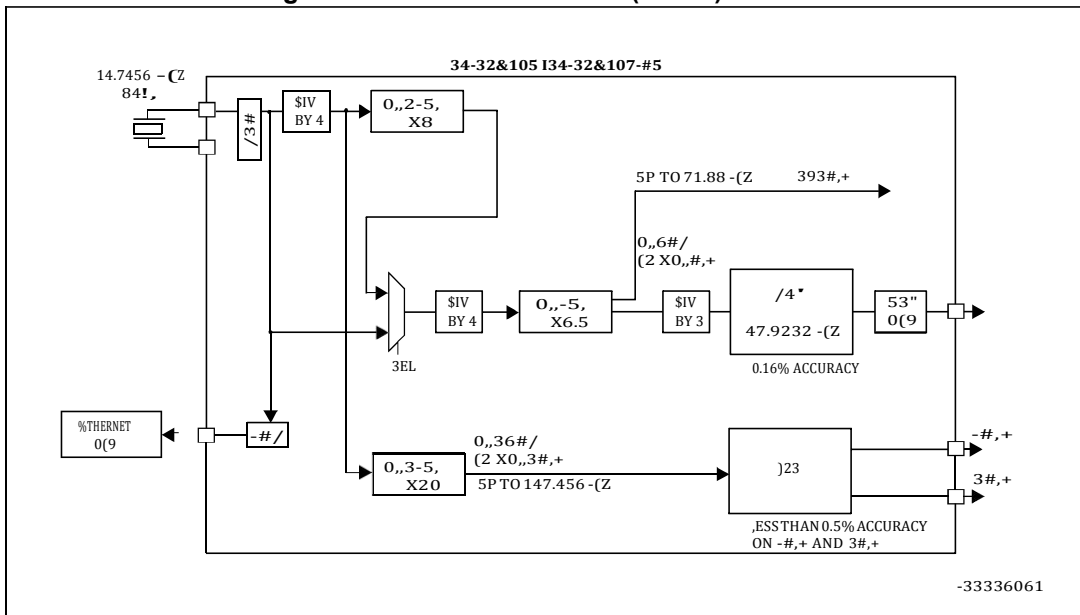




Table 63. PLL configurations

Application	Crystal value in MHz (XT1)	PREDIV2	PLL2MUL	PLLSRC	PREDIV1	PLLMUL	USB prescaler (PLL VCO output)	PLL3MUL	I2Sn clock input	MCO (main clock output)
Ethernet only	25	/5	PLL2ON x8	PLL2	/5	PLLON x9	NA	PLL3ON x10	NA	XT1 (MII) PLL3 (RMII)
Ethernet + OTG	25	/5	PLL2ON x8	PLL2	/5	PLLON x9	/3	PLL3ON x10	NA	XT1 (MII) PLL3 (RMII)
Ethernet + OTG + basic audio	25	/5	PLL2ON x8	PLL2	/5	PLLON x9	/3	PLL3ON x10	PLL	XT1 (MII) PLL3 (RMII)
Ethernet + OTG + Audio class I <sup>2</sup> S <sup>(1)</sup>	14.7456	/4	PLL2ON x12	PLL2	/4	PLLON x6.5	/3	PLL3ON x20	PLL3 VCO Out	NA ETH PHY must use its own crystal
OTG only	8	NA	PLL2OFF	XT1	/1	PLLON x9	/3	PLL3OFF	NA	NA
OTG + basic audio	8	NA	PLL2OFF	XT1	/1	PLLON x9	/3	PLL3OFF	PLL	NA
OTG + Audio class I <sup>2</sup> S <sup>(1)</sup>	14.7456	/4	PLL2ON x12	PLL2	/4	PLLON x6.5	/3	PLL3ON x20	PLL3 VCO Out	NA
Audio class I <sup>2</sup> S only <sup>(1)</sup>	14.7456	/4	PLL2ON x12	PLL2	/4	PLLON x6.5	NA	PLL3ON x20	PLL3 VCO out	NA

1. SYSCLK is set to be at 72 MHz except in this case where SYSCLK is at 71.88MHz.

Table 64 give the I<sub>DD</sub> run mode values that correspond to the conditions specified in Table 63.



**Table 64. Applicative current consumption in Run mode, code with data processing running from Flash**

Symbol	parameter	Conditions <sup>(1)</sup>	Typ <sup>(2)</sup>	Max <sup>(2)</sup>		Unit
				85 °C	105 °C	
I <sub>DD</sub>	Supply current in run mode	External clock, all peripherals enabled except ethernet, HSE = 8 MHz, f <sub>HCLK</sub> = 72 MHz, no MCO	57	63	64	mA
		External clock, all peripherals enabled except ethernet, HSE = 14.74 MHz, f <sub>HCLK</sub> = 72 MHz, no MCO	60.5	67	68	
		External clock, all peripherals enabled except OTG, HSE = 25 MHz, f <sub>HCLK</sub> = 72 MHz, MCO = 25 MHz	53	60.7	61	
		External clock, all peripherals enabled, HSE = 25 MHz, f <sub>HCLK</sub> = 72 MHz, MCO = 25 MHz	60.5	65.5	66	
		External clock, all peripherals enabled, HSE = 25 MHz, f <sub>HCLK</sub> = 72 MHz, MCO = 50 MHz	64	69.7	70	
		External clock, all peripherals enabled, HSE = 50 MHz <sup>(3)</sup> , f <sub>HCLK</sub> = 72 MHz, no MCO	62.5	67.5	68	
		External clock, only OTG enabled, HSE = 8 MHz, f <sub>HCLK</sub> = 48 MHz, no MCO	26.7	None	None	
		External clock, only ethernet enabled, HSE = 25 MHz, f <sub>HCLK</sub> = 25 MHz, MCO = 25 MHz	14.3	None	None	

1. V<sub>DD</sub> = 3.3 V.
2. Based on characterization, not tested in production.
3. External oscillator.



## 8 Revision history

**Table 65. Document revision history**

Date	Revision	Changes
18-Dec-2008	1	Initial release.
20-Feb-2009	2	<p>I/O information clarified <i>on page 1. Figure 4: STM32F105xxx and STM32F107xxx connectivity line BGA100 ballout top view</i> corrected.</p> <p><i>Section 2.3.8: Boot modes</i> updated.</p> <p>PB4, PB13, PB14, PB15, PB3/TRACESWO moved from Default column to Remap column, plus small additional changes in <i>Table 5: Pin definitions</i>.</p> <p>Consumption values modified in <i>Section 5.3.5: Supply current characteristics</i>.</p> <p>Note modified in <i>Table 13: Maximum current consumption in Run mode, code with data processing running from Flash</i> and <i>Table 15: Maximum current consumption in Sleep mode, code running from Flash or RAM</i>.</p> <p><i>Table 20: High-speed external user clock characteristics</i> and <i>Table 21: Low-speed external user clock characteristics</i> modified.</p> <p><i>Table 27: PLL characteristics</i> modified and <i>Table 28: PLL2 and PLL3 characteristics</i> added.</p>





**Table 65. Document revision history (continued)**

Date	Revision	Changes
19-Jun-2009	3	<p><i>Section 2.3.8: Boot modes</i> and <i>Section 2.3.20: Ethernet MAC interface with dedicated DMA and IEEE 1588 support</i> updated.</p> <p><i>Section 2.3.24: Remap capability</i> added.</p> <p><i>Figure 1: STM32F105xx and STM32F107xx connectivity line block diagram</i> and <i>Figure 5: Memory map</i> updated.</p> <p>In <i>Table 5: Pin definitions</i>:</p> <ul style="list-style-type: none"> <li>– I2S3_WS, I2S3_CK and I2S3_SD default alternate functions added</li> <li>– small changes in signal names</li> <li>– <i>Note 6</i> modified</li> <li>– ETH_MII_PPS_OUT and ETH_RMII_PPS_OUT replaced by ETH_PPS_OUT</li> <li>– ETH_MII_MDIO and ETH_RMII_MDIO replaced by ETH_MDIO</li> <li>– ETH_MII_MDC and ETH_RMII_MDC replaced by ETH_MDC</li> </ul> <p>Figures: <i>Typical current consumption in Run mode versus frequency (at 3.6 V) - code with data processing running from RAM, peripherals enabled</i> and <i>Typical current consumption in Run mode versus frequency (at 3.6 V) - code with data processing running from RAM, peripherals disabled</i> removed.</p> <p><i>Table 13: Maximum current consumption in Run mode, code with data processing running from Flash</i>, <i>Table 14: Maximum current consumption in Run mode, code with data processing running from RAM</i> and <i>Table 15: Maximum current consumption in Sleep mode, code running from Flash or RAM</i> are to be determined.</p> <p><i>Figure 12</i> and <i>Figure 13</i> show typical curves. PLL1 renamed to PLL. I<sub>DD</sub> supply current in Stop mode modified in <i>Table 16: Typical and maximum current consumptions in Stop and Standby modes</i>.</p> <p><i>Figure 11: Typical current consumption in Stop mode with regulator in Run mode versus temperature at different VDD values</i>, <i>Figure 13: Typical current consumption in Standby mode versus temperature at different VDD values</i> and <i>Figure 13: Typical current consumption in Standby mode versus temperature at different VDD values</i> updated.</p> <p><i>Table 17: Typical current consumption in Run mode, code with data processing running from Flash</i>, <i>Table 18: Typical current consumption in Sleep mode, code running from Flash or RAM</i> and <i>Table 19: Peripheral current consumption</i> updated.</p> <p>f<sub>HSE_ext</sub> modified in <i>Table 20: High-speed external user clock characteristics</i>.</p> <p>Min PLL input clock (f<sub>PLL_IN</sub>), f<sub>PLL_OUT</sub> min and f<sub>PLL_VCO</sub> min modified in <i>Table 27: PLL characteristics</i>.</p> <p>ACC<sub>HSI</sub> max values modified in <i>Table 24: HSI oscillator characteristics</i>. <i>Table 31: EMS characteristics</i> and <i>Table 32: EMI characteristics</i> updated. <i>Table 43: SPI characteristics</i> updated.</p> <p>Modified: <i>Figure 28: I2S slave timing diagram (Philips protocol)(1)</i>, <i>Figure 29: I2S master timing diagram (Philips protocol)(1)</i> and <i>Figure 31: Ethernet SMI timing diagram</i>.</p> <p>BGA100 package removed.</p> <p><i>Section 6.4: Thermal characteristics</i> added. Small text changes.</p>



**Table 65. Document revision history (continued)**

Date	Revision	Changes
14-Sep-2009	4	<p>Document status promoted from Preliminary data to full datasheet.</p> <p>Number of DACs corrected in <a href="#">Table 3: STM32F105xx and STM32F107xx family versus STM32F103xx family</a>.</p> <p><a href="#">Note 5</a> added in <a href="#">Table 5: Pin definitions</a>.</p> <p>V<sub>RERINT</sub> and T<sub>Coeff</sub> added to <a href="#">Table 12: Embedded internal reference voltage</a>.</p> <p>Values added to <a href="#">Table 13: Maximum current consumption in Run mode, code with data processing running from Flash</a>, <a href="#">Table 14: Maximum current consumption in Run mode, code with data processing running from RAM</a> and <a href="#">Table 15: Maximum current consumption in Sleep mode, code running from Flash or RAM</a>.</p> <p>Typical I<sub>DD_VBAT</sub> value added in <a href="#">Table 16: Typical and maximum current consumptions in Stop and Standby modes</a>.</p> <p><a href="#">Figure 10: Typical current consumption on VBAT with RTC on vs. temperature at different VBAT values</a> added.</p> <p>Values modified in <a href="#">Table 17: Typical current consumption in Run mode, code with data processing running from Flash</a> and <a href="#">Table 18: Typical current consumption in Sleep mode, code running from Flash or RAM</a>.</p> <p>f<sub>HSE_ext</sub> min modified in <a href="#">Table 20: High-speed external user clock characteristics</a>.</p> <p>C<sub>L1</sub> and C<sub>L2</sub> replaced by C in <a href="#">Table 22: HSE 3-25 MHz oscillator characteristics</a> and <a href="#">Table 23: LSE oscillator characteristics (f<sub>LSE</sub> = 32.768 kHz)</a>, notes modified and moved below the tables. <a href="#">Note 1</a> modified below <a href="#">Figure 16: Typical application with an 8 MHz crystal</a>.</p> <p>Conditions removed from <a href="#">Table 26: Low-power mode wakeup timings</a>.</p> <p>Standards modified in <a href="#">Section 5.3.10: EMC characteristics on page 54</a>, conditions modified in <a href="#">Table 31: EMS characteristics</a>.</p> <p>Jitter maximum values added to <a href="#">Table 27: PLL characteristics</a> and <a href="#">Table 28: PLL2 and PLL3 characteristics</a>.</p> <p>R<sub>PU</sub> and R<sub>PD</sub> modified in <a href="#">Table 36: I/O static characteristics</a>.</p> <p>Condition added for V<sub>NF(NRST)</sub> parameter in <a href="#">Table 39: NRST pin characteristics</a>. Note removed and R<sub>PD</sub>, R<sub>PU</sub> values added in <a href="#">Table 46: USB OTG FS DC electrical characteristics</a>.</p> <p><a href="#">Table 48: Ethernet DC electrical characteristics</a> added.</p> <p>Parameter values added to <a href="#">Table 49: Dynamic characteristics: Ethernet MAC signals for SMI</a>, <a href="#">Table 50: Dynamic characteristics: Ethernet MAC signals for RMII</a> and <a href="#">Table 51: Dynamic characteristics: Ethernet MAC signals for MII</a>.</p> <p>C<sub>ADC</sub> and R<sub>AIN</sub> parameters modified in <a href="#">Table 52: ADC characteristics</a>. R<sub>AIN</sub> max values modified in <a href="#">Table 53: RAIN max for f<sub>ADC</sub> = 14 MHz</a>.</p> <p><a href="#">Table 56: DAC characteristics</a> modified. <a href="#">Figure 38: 12-bit buffered /non-buffered DAC</a> added.</p> <p><a href="#">Table 64: Applicative current consumption in Run mode, code with data processing running from Flash</a> added.</p> <p>Small text changes.</p>



Table 65. Document revision history (continued)

Date	Revision	Changes
11-May-2010	5	<p>Added BGA package.</p> <p><i>Table 5: Pin definitions:</i>            ETH_RMII_RXD0 and ETH_RMII_RXD1 added in remap column for PD9 and PD10, respectively.</p> <p>Note added to ETH_MII_RX_DV, ETH_MII_RXD0, ETH_MII_RXD1, ETH_MII_RXD2 and ETH_MII_RXD3</p> <p>Updated <i>Table 36: I/O static characteristics on page 57</i></p> <p>Added <i>Figure 18: Standard I/O input characteristics - CMOS port</i> to <i>Figure 21: 5 V tolerant I/O input characteristics - TTL port</i></p> <p>Updated <i>Table 43: SPI characteristics on page 66.</i></p> <p>Updated <i>Table 44: I2S characteristics on page 69.</i></p> <p>Updated <i>Table 48: Ethernet DC electrical characteristics on page 72.</i></p> <p>Updated <i>Table 49: Dynamic characteristics: Ethernet MAC signals for SMI on page 72.</i></p> <p>Updated <i>Table 50: Dynamic characteristics: Ethernet MAC signals for RMII on page 73</i></p> <p>Updated <i>Figure 59: USB O44TG FS + Ethernet solution on page 100.</i></p> <p>Updated <i>Figure 60: USB OTG FS + I2S (Audio) solution on page 100</i></p>
01-Aug-2011	6	<p>Changed SRAM size to 64 KB on all parts.</p> <p>Updated PD0 and PD1 description in <i>Table 5: Pin definitions on page 27</i></p> <p>Updated footnotes below <i>Table 6: Voltage characteristics on page 36</i> and <i>Table 7: Current characteristics on page 36</i></p> <p>Updated tw min in <i>Table 20: High-speed external user clock characteristics on page 47</i></p> <p>Updated startup time in <i>Table 23: LSE oscillator characteristics (fLSE = 32.768 kHz) on page 50</i></p> <p>Added <i>Section 5.3.12: I/O current injection characteristics on page 56</i></p> <p>Updated <i>Table 36: I/O static characteristics on page 57</i></p> <p>Add Interna code V to <i>Table 62: Ordering information scheme on page 94</i></p>
06-Mar-2014	7	<p>Added a "Packing" entry to <i>Table 62: Ordering information scheme</i> including "Blank = tray" and "TR = Tape and reel".</p> <p>Referenced 4 Figures: <i>Figure 41, Figure 49, Figure 59</i> and <i>Figure 60.</i></p> <p>Updated the "Package" line with "BGA100" in <i>Table 2: STM32F105xx and STM32F107xx features and peripheral counts.</i></p>



**Table 65. Document revision history (continued)**

Date	Revision	Changes
06-Mar-2015	8	<p>Updated <a href="#">Table 40: LFBGA100 – 100-ball low profile fine pitch ball grid array, 10 x 10 mm, 0.8 mm pitch, package mechanical data</a>, <a href="#">Table 59: LQPF100 - 100-pin, 14 x 14 mm low-profile quad flat package mechanical data</a> and <a href="#">Table 60: LQFP64 – 10 x 10 mm 64 pin low-profile quad flat package mechanical data</a></p> <p>Updated <a href="#">Figure 14: High-speed external clock source AC timing diagram</a>; <a href="#">Figure 39: LFBGA100 - 10 x 10 mm low profile fine pitch ball grid array package outline</a>, <a href="#">Figure 43: LQFP100 – 14 x 14 mm 100 pin low-profile quad flat package outline</a>, <a href="#">Figure 44: LQFP100 - 100-pin, 14 x 14 mm low-profile quad flat recommended footprint</a>, <a href="#">Figure 46: LQFP64 – 10 x 10 mm 64 pin low-profile quad flat package outline</a> and <a href="#">Figure 47: LQFP64 - 64-pin, 10 x 10 mm low-profile quad flat recommended footprint</a></p> <p>Added <a href="#">Figure 45: LQFP100 marking example (package top view)</a>, <a href="#">Figure 48: LQFP64 marking example (package top view)</a></p>
3-Sept-2015	9	<p>Updated:</p> <ul style="list-style-type: none"> <li>– <a href="#">Table 19: Peripheral current consumption</a></li> <li>– <a href="#">Figure 44: LQFP100 - 100-pin, 14 x 14 mm low-profile quad flat recommended footprint</a></li> <li>– <a href="#">Table 58: LFBGA100 recommended PCB design rules (0.8mm pitch BGA)</a></li> </ul>
22-Mar-2017	10	<p>Updated:</p> <ul style="list-style-type: none"> <li>– <a href="#">Table 5: Pin definitions</a></li> <li>– <a href="#">Section 6: Package information</a></li> </ul> <p>Added:</p> <ul style="list-style-type: none"> <li>– <a href="#">Figure 42: LFBGA100 marking example (package topview)</a></li> </ul>





**IMPORTANT NOTICE – PLEASE READ CAREFULLY**

STMicroelectronics NV and its subsidiaries (“ST”) reserve the right to make changes, corrections, enhancements, modifications, and improvements to ST products and/or to this document at any time without notice. Purchasers should obtain the latest relevant information on ST products before placing orders. ST products are sold pursuant to ST’s terms and conditions of sale in place at the time of order acknowledgement.

Purchasers are solely responsible for the choice, selection, and use of ST products and ST assumes no liability for application assistance or the design of Purchasers’ products.

No license, express or implied, to any intellectual property right is granted by ST herein.

Resale of ST products with provisions different from the information set forth herein shall void any warranty granted by ST for such product.

ST and the ST logo are trademarks of ST. All other product or service names are the property of their respective owners.

Information in this document supersedes and replaces information previously supplied in any prior versions of this document.

© 2017 STMicroelectronics – All rights reserved

