



东莞天富电子科技有限公司

# 产品承认书

<b>CUSTOMER</b>	<b>CUSTOMER NO.</b>	<b>TF PART NO.</b>
		<b>TFS5010</b>
<b>DESCRIPTION:</b>	<b>10/100/1000 BASE-T TRANSFORMER MODULES</b>	

**ATTACHMENT:**

■ SPECIFICATION

■ SAMPLE          Q'TY OF SAMPLES      5      PCS

<b>CUSTOMER APPROVAL</b> (客户承认章)	<b>KDY APPROVAL</b> (公司承认章)

<b>SALES BY:</b>		<b>DRAWN BY:</b>	<b>Season</b>
<b>QA DEPT. :</b>		<b>CHECKED BY:</b>	<b>DellyDeng</b>
<b>ENG. DEPT.:</b>		<b>APPROVAL BY:</b>	<b>JamesYan</b>



## 1. FEATURES:

- 1.1 Compatible with various 10/100/1000 Base-TX transceiver requiring 1:1 transmit and receive turns ratio
- 1.2 Compliant with IEEE 802.3 standard including baseline wander compensation specification of 350uH OCL from@25°C
- 1.3 Low profile Surface Mount Packaging designed for Hi-Temp Reflow Process (255°C peak)
- 1.4 Single channel interface for 10/100/1000Mbps Ethernet applications with CMC's tuned to Enhance EMC system performance
- 1.5 Operating Temperature range:-40°C to 85°C

## 2.ELECTRICAL SPECIFICATIONS @25°C

- 2.1 OCL : 350 uH Min. @ 100 KHz, 100mV
- 2.2 Leakage Inductance: 0.5 uH Max. @ 100KHz, 0.1V
- 2.3 Cw/w: 30 pF Max. @ 100KHz, 0.1V
- 2.4 DCR: 1.30Ω Max.
- 2.5 Turns Ratio(±5%): 1CT:1CT(TX), 1CT:1CT(RX)
- 2.6 Insertion Loss: -1.0 dB Max. @ 1-100MHz
- 2.7 Return Loss: -18 dB Min. @ 1-30MHz
  - 14 dB Min. @ 40 MHz
  - 12 dB Min. @ 50 MHz
  - 10 dB Min.@ 60-80 MHz
- 2.8 Cross Talk: -45 dB Min.@ 30 MHz
  - 40 dB Min.@ 60 MHz
  - 35 dB Min.@ 100MHz
- 2.9 Common Mode Rejection : -33 dB Min.@ 1-100 MHz
- 2.10 Isolation HI-POT: 1500Vrms 1mA 1Second

DRAWN BY:	CHECKED BY:	APPROVED BY:	CUSTOMER:
<b>Season</b>	<b>DellyDeng</b>	<b>JamesYan</b>	PART NO. : <b>TFS5010</b>
DONGGUAN TIANFU ELECTRONICS CO.,LTD			REV.: A
			PAGE: 2 OF 4



### 3. SCHEMATIC

CS:

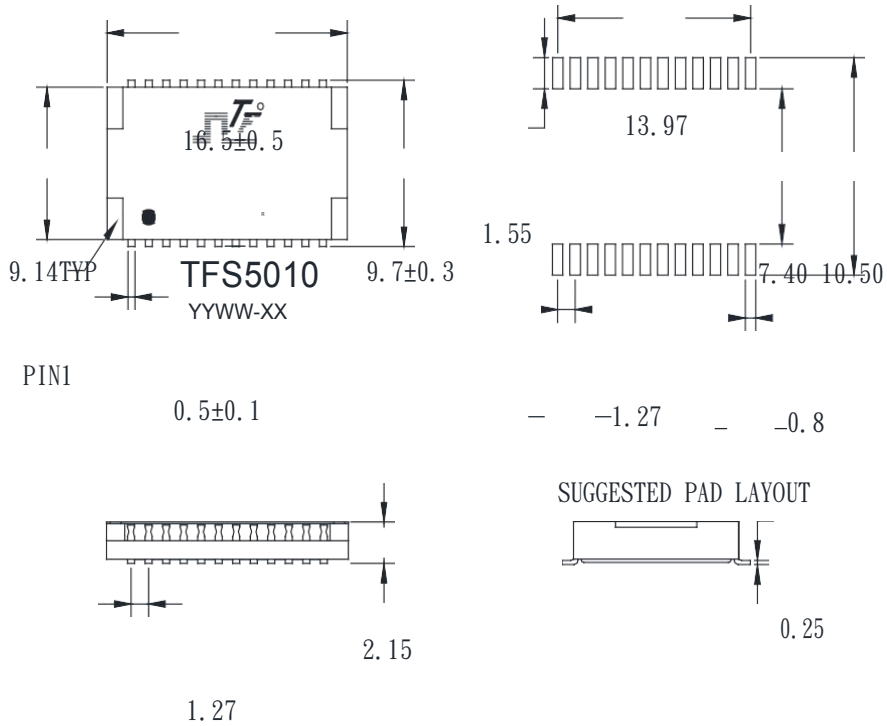
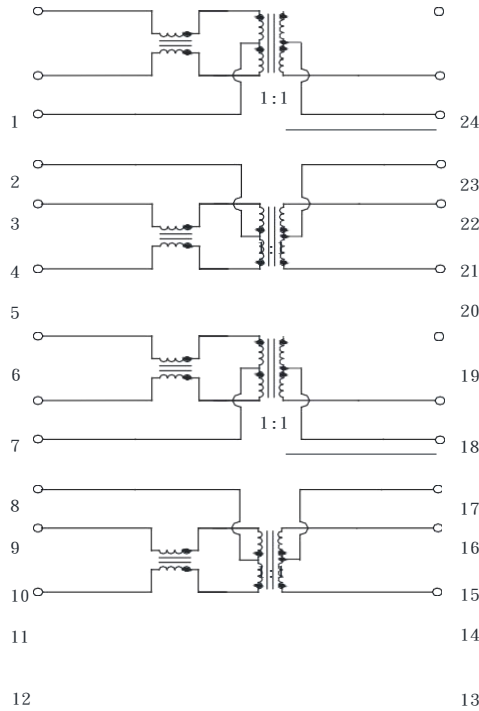

DRAWN BY:	CHECKED BY:	APPROVED BY:	CUSTOMER:
Season	DellyDeng	JamesYan	PART NO. : TFS5009
DONGGUAN TIANFU ELECTRONICS CO.,LTD			REV.: A
			PAGE: 3 OF 4



## Advice Soldering Profile

Profile Feature	
Average Ramp-Up Rate (Ts max. to Tp)	3° C/second max.
<b>Preheat</b> -Temperature Min (Ts min.) -Temperature Max (Ts max.) -Time (ts min. to ts max.)	150 °C 200 °C 60-120 seconds
<b>Time maintained above:</b> -Temperature (TL) -Time (tL)	217 °C 60-150 seconds
Peak/Classification Temperature (Tp)	250°C
Time within 5 °C of actual Peak Temperature (tp)	10seconds max.
Ramp-Down Rate	6 °C/second max.
Time 25 °C to Peak Temperature	8 minutes max.

