

STM32F103x8 STM32F103xB

Medium-density performance line ARM-based 32-bit MCU with 64 or 128 KB Flash, USB, CAN, 7 timers, 2 ADCs, 9 communication interfaces

Features

- Core: ARM 32-bit Cortex™-M3 CPU
 - 72 MHz maximum frequency, 1.25 DMIPS/MHz (Dhrystone 2.1) performance at 0 wait state memory access
 - Single-cycle multiplication and hardware division
- Memories
 - 64 or 128 Kbytes of Flash memory
 - 20 Kbytes of SRAM
- Clock, reset and supply management
 - 2.0 to 3.6 V application supply and I/Os
 - POR, PDR, and programmable voltage detector (PVD)
 - 4-to-16 MHz crystal oscillator
 - Internal 8 MHz factory-trimmed RC
 - Internal 40 kHz RC
 - PLL for CPU clock
 - 32 kHz oscillator for RTC with calibration
- Low power
 - Sleep, Stop and Standby modes
 - V_{BAT} supply for RTC and backup registers
- 2 x 12-bit, 1 μs A/D converters (up to 16 channels)
 - Conversion range: 0 to 3.6 V
 - Dual-sample and hold capability
 - Temperature sensor
- DMA
 - 7-channel DMA controller
 - Peripherals supported: timers, ADC, SPIs, I²Cs and USARTs
- Up to 80 fast I/O ports
 - 26/37/51/80 I/Os, all mappable on 16 external interrupt vectors and almost all 5 V-tolerant

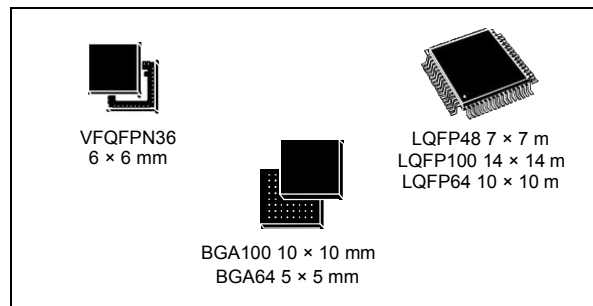

- Debug mode
 - Serial wire debug (SWD) & JTAG interfaces
- 7 timers
 - Three 16-bit timers, each with up to 4 IC/OC/PWM or pulse counter and quadrature (incremental) encoder input
 - 16-bit, motor control PWM timer with dead-time generation and emergency stop
 - 2 watchdog timers (Independent and Window)
 - SysTick timer: a 24-bit downcounter
- Up to 9 communication interfaces
 - Up to 2 x I²C interfaces (SMBus/PMBus)
 - Up to 3 USARTs (ISO 7816 interface, LIN, IrDA capability, modem control)
 - Up to 2 SPIs (18 Mbit/s)
 - CAN interface (2.0B Active)
 - USB 2.0 full-speed interface
- CRC calculation unit, 96-bit unique ID
- Packages are ECOPACK®

Table 1. Device summary

Reference	Part number
STM32F103x8	STM32F103C8, STM32F103R8 STM32F103V8, STM32F103T8
STM32F103xB	STM32F103RB STM32F103VB, STM32F103CB

Contents

- 1 Introduction.....9**
- 2 Description..... 9**
 - 2.1 Device overview..... 10
 - 2.2 Full compatibility throughout the family..... 11
 - 2.3 Overview..... 12
 - 2.3.1 ARM® Cortex™-M3 core with embedded Flash and SRAM..... 12
 - 2.3.2 Embedded Flash memory..... 12
 - 2.3.3 CRC (cyclic redundancy check) calculation unit..... 12
 - 2.3.4 Embedded SRAM..... 12
 - 2.3.5 Nested vectored interrupt controller (NVIC)..... 12
 - 2.3.6 External interrupt/event controller (EXTI)..... 13
 - 2.3.7 Clocks and startup..... 13
 - 2.3.8 Boot modes..... 13
 - 2.3.9 Power supply schemes..... 13
 - 2.3.10 Power supply supervisor..... 13
 - 2.3.11 Voltage regulator..... 14
 - 2.3.12 Low-power modes..... 14
 - 2.3.13 DMA..... 15
 - 2.3.14 RTC (real-time clock) and backup registers..... 15
 - 2.3.15 Timers and watchdogs..... 15
 - 2.3.16 I²C bus..... 17
 - 2.3.17 Universal synchronous/asynchronous receiver transmitter (USART)..... 17
 - 2.3.18 Serial peripheral interface (SPI)..... 17
 - 2.3.19 Controller area network (CAN)..... 17
 - 2.3.20 Universal serial bus (USB)..... 17
 - 2.3.21 GPIOs (general-purpose inputs/outputs)..... 18
 - 2.3.22 ADC (analog-to-digital converter)..... 18
 - 2.3.23 Temperature sensor..... 18
 - 2.3.24 Serial wire JTAG debug port (SWJ-DP)..... 18
- 3 Pinouts and pin description..... 21**
- 4 Memory mapping.....31**

5	Electrical characteristics.....	32
5.1	Parameter conditions.....	32
5.1.1	Minimum and maximum values.....	32
5.1.2	Typical values.....	32
5.1.3	Typical curves.....	32
5.1.4	Loading capacitor.....	32
5.1.5	Pin input voltage.....	32
5.1.6	Power supply scheme.....	33
5.1.7	Current consumption measurement.....	34
5.2	Absolute maximum ratings.....	34
5.3	Operating conditions.....	35
5.3.1	General operating conditions.....	35
5.3.2	Operating conditions at power-up / power-down.....	36
5.3.3	Embedded reset and power control block characteristics.....	36
5.3.4	Embedded reference voltage.....	38
5.3.5	Supply current characteristics.....	38
5.3.6	External clock source characteristics.....	47
5.3.7	Internal clock source characteristics.....	50
5.3.8	PLL characteristics.....	52
5.3.9	Memory characteristics.....	52
5.3.10	EMC characteristics.....	53
5.3.11	Absolute maximum ratings (electrical sensitivity).....	55
5.3.12	I/O port characteristics.....	56
5.3.13	NRST pin characteristics.....	59
5.3.14	TIM timer characteristics.....	60
5.3.15	Communications interfaces.....	61
5.3.16	CAN (controller area network) interface.....	66
5.3.17	12-bit ADC characteristics.....	67
5.3.18	Temperature sensor characteristics.....	71
6	Package characteristics.....	72
6.1	Package mechanical data.....	72
6.2	Thermal characteristics.....	81
6.2.1	Reference document.....	81
6.2.2	Selecting the product temperature range.....	82
7	Ordering information scheme.....	84
	Doc ID 13587 Rev 10	3/91
8	Revision history.....	85
	Doc ID 13587 Rev 10	



List of tables

Table 1.	Device summary.....	1
Table 2.	STM32F103xx medium-density device features and peripheral counts.....	10
Table 3.	STM32F103xx family.....	11
Table 4.	Timer feature comparison.....	15
Table 5.	Medium-density STM32F103xx pin definitions.....	26
Table 6.	Voltage characteristics.....	34
Table 7.	Current characteristics.....	35
Table 8.	Thermal characteristics.....	35
Table 9.	General operating conditions.....	35
Table 10.	Operating conditions at power-up / power-down.....	36
Table 11.	Embedded reset and power control block characteristics.....	37
Table 12.	Embedded internal reference voltage.....	38
Table 13.	Maximum current consumption in Run mode, code with data processing running from Flash.....	39
Table 14.	Maximum current consumption in Run mode, code with data processing running from RAM.....	39
Table 15.	Maximum current consumption in Sleep mode, code running from Flash or RAM.....	41
Table 16.	Typical and maximum current consumptions in Stop and Standby modes.....	42
Table 17.	Typical current consumption in Run mode, code with data processing running from Flash.....	44
Table 18.	Typical current consumption in Sleep mode, code running from Flash or RAM.....	45
Table 19.	Peripheral current consumption.....	46
Table 20.	High-speed external user clock characteristics.....	47
Table 21.	Low-speed external user clock characteristics.....	47
Table 22.	HSE 4-16 MHz oscillator characteristics.....	49
Table 23.	LSE oscillator characteristics ($f_{LSE} = 32.768$ kHz).....	50
Table 24.	HSI oscillator characteristics.....	51
Table 25.	LSI oscillator characteristics.....	51
Table 26.	Low-power mode wakeup timings.....	52
Table 27.	PLL characteristics.....	52
Table 28.	Flash memory characteristics.....	52
Table 29.	Flash memory endurance and data retention.....	53
Table 30.	EMS characteristics.....	54
Table 31.	EMI characteristics.....	54
Table 32.	ESD absolute maximum ratings.....	55
Table 33.	Electrical sensitivities.....	55
Table 34.	I/O static characteristics.....	56
Table 35.	Output voltage characteristics.....	57
Table 36.	I/O AC characteristics.....	58
Table 37.	NRST pin characteristics.....	59
Table 38.	TIMx characteristics.....	60
Table 39.	I ² C characteristics.....	61
Table 40.	SCL frequency ($f_{PCLK1} = 36$ MHz., $V_{DD} = 3.3$ V).....	62
Table 41.	SPI characteristics.....	63
Table 42.	USB startup time.....	65
Table 43.	USB DC electrical characteristics.....	66
Table 44.	USB: Full-speed electrical characteristics.....	66



Table 45.	ADC characteristics.....	67
Table 46.	R_{AIN} max for $f_{ADC} = 14$ MHz.....	68
Table 47.	ADC accuracy - limited test conditions.....	68
Table 48.	ADC accuracy.....	69
Table 49.	TS characteristics.....	71
Table 50.	VFQFPN36 6 x 6 mm, 0.5 mm pitch, package mechanical data.....	73
Table 51.	LFPGA100 - low profile fine pitch ball grid array package mechanical data.....	74
Table 52.	LQPF100, 100-pin low-profile quad flat package mechanical data.....	76
Table 53.	LQFP64, 64-pin low-profile quad flat package mechanical data.....	77
Table 54.	TFBGA64 - 8 x 8 active ball array, 5 x 5 mm, 0.5 mm pitch, package mechanical data.....	78
Table 55.	LQFP48, 48-pin low-profile quad flat package mechanical data.....	80
Table 56.	Package thermal characteristics.....	81
Table 57.	Ordering information scheme.....	84



List of figures

Figure 1.	STM32F103xx performance line block diagram.....	19
Figure 2.	Clock tree.....	20
Figure 3.	STM32F103xx performance line LFBGA100 ballout.....	21
Figure 4.	STM32F103xx performance line LQFP100 pinout.....	22
Figure 5.	STM32F103xx performance line LQFP64 pinout.....	23
Figure 6.	STM32F103xx performance line TFBGA64 ballout.....	24
Figure 7.	STM32F103xx performance line LQFP48 pinout.....	25
Figure 8.	STM32F103xx Performance Line VFQFPN36 pinout.....	25
Figure 9.	Memory map.....	31
Figure 10.	Pin loading conditions.....	33
Figure 11.	Pin input voltage.....	33
Figure 12.	Power supply scheme.....	33
Figure 13.	Current consumption measurement scheme.....	34
Figure 14.	Typical current consumption in Run mode versus frequency (at 3.6 V) - code with data processing running from RAM, peripherals enabled.....	40
Figure 15.	Typical current consumption in Run mode versus frequency (at 3.6 V) - code with data processing running from RAM, peripherals disabled.....	40
Figure 16.	Typical current consumption in Stop mode with regulator in Run mode versus temperature at $V_{DD} = 3.3\text{ V}$ and 3.6 V	42
Figure 17.	Typical current consumption in Stop mode with regulator in Low-power mode versus temperature at $V_{DD} = 3.3\text{ V}$ and 3.6 V	43
Figure 18.	Typical current consumption in Standby mode versus temperature at $V_{DD} = 3.3\text{ V}$ and 3.6 V	43
Figure 19.	High-speed external clock source AC timing diagram.....	48
Figure 20.	Low-speed external clock source AC timing diagram.....	48
Figure 21.	Typical application with an 8 MHz crystal.....	49
Figure 22.	Typical application with a 32.768 kHz crystal.....	50
Figure 23.	I/O AC characteristics definition.....	59
Figure 24.	Recommended NRST pin protection.....	60
Figure 25.	I ² C bus AC waveforms and measurement circuit.....	62
Figure 26.	SPI timing diagram - slave mode and CPHA = 0.....	64
Figure 27.	SPI timing diagram - slave mode and CPHA = 1 ⁽¹⁾	64
Figure 28.	SPI timing diagram - master mode ⁽¹⁾	65
Figure 29.	USB timings: definition of data signal rise and fall time.....	66
Figure 30.	ADC accuracy characteristics.....	69
Figure 31.	Typical connection diagram using the ADC.....	70
Figure 32.	Power supply and reference decoupling (V_{REF+} not connected to V_{DDA}).....	70
Figure 33.	Power supply and reference decoupling (V_{REF+} connected to V_{DDA}).....	71
Figure 34.	VFQFPN36 6 x 6 mm, 0.5 mm pitch, package outline ⁽¹⁾	73
Figure 35.	Recommended footprint (dimensions in mm) ⁽¹⁾⁽²⁾⁽³⁾	73
Figure 36.	LFBGA100 - low profile fine pitch ball grid array package outline.....	74
Figure 37.	Recommended PCB design rules (0.80/0.75 mm pitch BGA).....	75
Figure 38.	LQFP100, 100-pin low-profile quad flat package outline.....	76
Figure 39.	Recommended footprint ⁽¹⁾	76
Figure 40.	LQFP64, 64-pin low-profile quad flat package outline.....	77
Figure 41.	Recommended footprint ⁽¹⁾	77
Figure 42.	TFBGA64 - 8 x 8 active ball array, 5 x 5 mm, 0.5 mm pitch, package outline.....	78
Figure 43.	Recommended PCB design rules for pads (0.5 mm pitch BGA).....	79



Figure 44. LQFP48, 48-pin low-profile quad flat package outline.....	80
Figure 45. Recommended footprint ⁽¹⁾	80
Figure 46. LQFP100 P _D max vs. T _A	83



1 Introduction

This datasheet provides the ordering information and mechanical device characteristics of the STM32F103x8 and STM32F103xB medium-density performance line microcontrollers. For more details on the whole STMicroelectronics STM32F103xx family, please refer to [Section 2.2: Full compatibility throughout the family](#).

The medium-density STM32F103xx datasheet should be read in conjunction with the low-, medium- and high-density STM32F10xxx reference manual.

The reference and Flash programming manuals are both available from the STMicroelectronics website www.st.com.

For information on the Cortex™-M3 core please refer to the Cortex™-M3 Technical Reference Manual, available from the www.arm.com website at the following address: <http://infocenter.arm.com/help/index.jsp?topic=/com.arm.doc.ddi0337e/>.

2 Description

The STM32F103x8 and STM32F103xB performance line family incorporates the high-performance ARM Cortex™-M3 32-bit RISC core operating at a 72 MHz frequency, high-speed embedded memories (Flash memory up to 128 Kbytes and SRAM up to 20 Kbytes), and an extensive range of enhanced I/Os and peripherals connected to two APB buses. All devices offer two 12-bit ADCs, three general purpose 16-bit timers plus one PWM timer, as well as standard and advanced communication interfaces: up to two I²Cs and SPIs, three USARTs, an USB and a CAN.

The STM32F103xx medium-density performance line family operates from a 2.0 to 3.6 V power supply. It is available in both the –40 to +85 °C temperature range and the –40 to +105 °C extended temperature range. A comprehensive set of power-saving mode allows the design of low-power applications.

The STM32F103xx medium-density performance line family includes devices in six different package types: from 36 pins to 100 pins. Depending on the device chosen, different sets of peripherals are included, the description below gives an overview of the complete range of peripherals proposed in this family.

These features make the STM32F103xx medium-density performance line microcontroller family suitable for a wide range of applications:

- Motor drive and application control
- Medical and handheld equipment
- PC peripherals gaming and GPS platforms
- Industrial applications: PLC, inverters, printers, and scanners
- Alarm systems, Video intercom, and HVAC

[Figure 1](#) shows the general block diagram of the device family.



2.1 Device overview

Table 2. STM32F103xx medium-density device features and peripheral counts

Peripheral		STM32F103Tx	STM32F103Cx	STM32F103Rx	STM32F103Vx
Flash - Kbytes		64	64 128	64 128	64 128
SRAM - Kbytes		20	20	20	20
Timers	General-purpose	3	3 3	3	3
	Advanced-control	1	1	1	1
Communication	SPI	1	2 2	2	2
	I ² C	1	2 2	2	2
	USART	2	3 3	3	3
	USB	1	1 1	1	1
	CAN	1	1 1	1	1
GPIOs		26	37	51	80
12-bit synchronized ADC Number of channels		2 10 channels	2 10 channels	2 16 channels	2 16 channels
CPU frequency		72 MHz			
Operating voltage		2.0 to 3.6 V			
Operating temperatures		Ambient temperatures: -40 to +85 °C / -40 to +105 °C (see Table 9) Junction temperature: -40 to + 125 °C (see Table 9)			
Packages		VFQFPN36	LQFP48	LQFP64, TFBGA64	LQFP100, LFBGA100



2.2 Full compatibility throughout the family

The STM32F103xx is a complete family whose members are fully pin-to-pin, software and feature compatible. In the reference manual, the STM32F103x4 and STM32F103x6 are identified as low-density devices, the STM32F103x8 and STM32F103xB are referred to as medium-density devices, and the STM32F103xC, STM32F103xD and STM32F103xE are referred to as high-density devices.

Low- and high-density devices are an extension of the STM32F103x8/B devices, they are specified in the STM32F103x4/6 and STM32F103xC/D/E datasheets, respectively. Low-density devices feature lower Flash memory and RAM capacities, less timers and peripherals. High-density devices have higher Flash memory and RAM capacities, and additional peripherals like SDIO, FSMC, I²S and DAC, while remaining fully compatible with the other members of the STM32F103xx family.

The STM32F103x4, STM32F103x6, STM32F103xC, STM32F103xD and STM32F103xE are a drop-in replacement for STM32F103x8/B medium-density devices, allowing the user to try different memory densities and providing a greater degree of freedom during the development cycle.

Moreover, the STM32F103xx performance line family is fully compatible with all existing STM32F101xx access line and STM32F102xx USB access line devices.

Table 3. STM32F103xx family

Pinout	Low-density devices		Medium-density devices		High-density devices		
	16 KB Flash	32 KB Flash ⁽¹⁾	64 KB Flash	128 KB Flash	256 KB Flash	384 KB Flash	512 KB Flash
	6 KB RAM	10 KB RAM	20 KB RAM	20 KB RAM	48 KB RAM	64 KB RAM	64 KB RAM
144					5 × USARTs		
100			3 × USARTs		4 × 16-bit timers, 2 × basic timers		
64	2 × USARTs 2 × 16-bit timers 1 × SPI, 1 × I ² C, USB,		3 × 16-bit timers 2 × SPIs, 2 × I ² Cs, USB, CAN, 1 × PWM timer		3 × SPIs, 2 × I ² Ss, 2 × I2Cs USB, CAN, 2 × PWM timers 3 × ADCs, 1 × DAC, 1 × SDIO FSMC (100 and 144 pins)		
48	CAN, 1 × PWM timer		2 × ADC				
36	2 × ADCs						

1. For orderable part numbers that do not show the A internal code after the temperature range code (6 or 7), the reference datasheet for electrical characteristics is that of the STM32F103x8/B medium-density devices.



2.3 Overview

2.3.1 ARM® Cortex™-M3 core with embedded Flash and SRAM

The ARM Cortex™-M3 processor is the latest generation of ARM processors for embedded systems. It has been developed to provide a low-cost platform that meets the needs of MCU implementation, with a reduced pin count and low-power consumption, while delivering outstanding computational performance and an advanced system response to interrupts.

The ARM Cortex™-M3 32-bit RISC processor features exceptional code-efficiency, delivering the high-performance expected from an ARM core in the memory size usually associated with 8- and 16-bit devices.

The STM32F103xx performance line family having an embedded ARM core, is therefore compatible with all ARM tools and software.

Figure 1 shows the general block diagram of the device family.

2.3.2 Embedded Flash memory

64 or 128 Kbytes of embedded Flash is available for storing programs and data.

2.3.3 CRC (cyclic redundancy check) calculation unit

The CRC (cyclic redundancy check) calculation unit is used to get a CRC code from a 32-bit data word and a fixed generator polynomial.

Among other applications, CRC-based techniques are used to verify data transmission or storage integrity. In the scope of the EN/IEC 60335-1 standard, they offer a means of verifying the Flash memory integrity. The CRC calculation unit helps compute a signature of the software during runtime, to be compared with a reference signature generated at link-time and stored at a given memory location.

2.3.4 Embedded SRAM

Twenty Kbytes of embedded SRAM accessed (read/write) at CPU clock speed with 0 wait states.

2.3.5 Nested vectored interrupt controller (NVIC)

The STM32F103xx performance line embeds a nested vectored interrupt controller able to handle up to 43 maskable interrupt channels (not including the 16 interrupt lines of Cortex™-M3) and 16 priority levels.

- Closely coupled NVIC gives low-latency interrupt processing
- Interrupt entry vector table address passed directly to the core
- Closely coupled NVIC core interface
- Allows early processing of interrupts
- Processing of *late arriving* higher priority interrupts
- Support for tail-chaining
- Processor state automatically saved
- Interrupt entry restored on interrupt exit with no instruction overhead

12/91

Doc ID 13587 Rev 10



This hardware block provides flexible interrupt management features with minimal interrupt latency.

2.3.6 External interrupt/event controller (EXTI)

The external interrupt/event controller consists of 19 edge detector lines used to generate interrupt/event requests. Each line can be independently configured to select the trigger event (rising edge, falling edge, both) and can be masked independently. A pending register maintains the status of the interrupt requests. The EXTI can detect an external line with a pulse width shorter than the Internal APB2 clock period. Up to 80 GPIOs can be connected to the 16 external interrupt lines.

2.3.7 Clocks and startup

System clock selection is performed on startup, however the internal RC 8 MHz oscillator is selected as default CPU clock on reset. An external 4-16 MHz clock can be selected, in which case it is monitored for failure. If failure is detected, the system automatically switches back to the internal RC oscillator. A software interrupt is generated if enabled. Similarly, full interrupt management of the PLL clock entry is available when necessary (for example on failure of an indirectly used external crystal, resonator or oscillator).

Several prescalers allow the configuration of the AHB frequency, the high-speed APB (APB2) and the low-speed APB (APB1) domains. The maximum frequency of the AHB and the high-speed APB domains is 72 MHz. The maximum allowed frequency of the low-speed APB domain is 36 MHz. See [Figure 2](#) for details on the clock tree.

2.3.8 Boot modes

At startup, boot pins are used to select one of three boot options:

- Boot from User Flash
- Boot from System Memory
- Boot from embedded SRAM

The boot loader is located in System Memory. It is used to reprogram the Flash memory by using USART1. For further details please refer to AN2606.

2.3.9 Power supply schemes

- $V_{DD} = 2.0$ to 3.6 V: external power supply for I/Os and the internal regulator. Provided externally through V_{DD} pins.
- V_{SSA} , $V_{DDA} = 2.0$ to 3.6 V: external analog power supplies for ADC, reset blocks, RCs and PLL (minimum voltage to be applied to V_{DDA} is 2.4 V when the ADC is used). V_{DDA} and V_{SSA} must be connected to V_{DD} and V_{SS} , respectively.
- $V_{BAT} = 1.8$ to 3.6 V: power supply for RTC, external clock 32 kHz oscillator and backup registers (through power switch) when V_{DD} is not present.

For more details on how to connect power pins, refer to [Figure 12: Power supply scheme](#).

2.3.10 Power supply supervisor

The device has an integrated power-on reset (POR)/power-down reset (PDR) circuitry. It is always active, and ensures proper operation starting from/down to 2 V. The device remains



in reset mode when V_{DD} is below a specified threshold, $V_{POR/PDR}$, without the need for an external reset circuit.

The device features an embedded programmable voltage detector (PVD) that monitors the V_{DD}/V_{DDA} power supply and compares it to the V_{PVD} threshold. An interrupt can be generated when V_{DD}/V_{DDA} drops below the V_{PVD} threshold and/or when V_{DD}/V_{DDA} is higher than the V_{PVD} threshold. The interrupt service routine can then generate a warning message and/or put the MCU into a safe state. The PVD is enabled by software.

Refer to [Table 11: Embedded reset and power control block characteristics](#) for the values of $V_{POR/PDR}$ and V_{PVD} .

2.3.11 Voltage regulator

The regulator has three operation modes: main (MR), low power (LPR) and power down.

- MR is used in the nominal regulation mode (Run)
- LPR is used in the Stop mode
- Power down is used in Standby mode: the regulator output is in high impedance: the kernel circuitry is powered down, inducing zero consumption (but the contents of the registers and SRAM are lost)

This regulator is always enabled after reset. It is disabled in Standby mode, providing high impedance output.

2.3.12 Low-power modes

The STM32F103xx performance line supports three low-power modes to achieve the best compromise between low power consumption, short startup time and available wakeup sources:

- **Sleep mode**

In Sleep mode, only the CPU is stopped. All peripherals continue to operate and can wake up the CPU when an interrupt/event occurs.

- **Stop mode**

The Stop mode achieves the lowest power consumption while retaining the content of SRAM and registers. All clocks in the 1.8 V domain are stopped, the PLL, the HSI RC and the HSE crystal oscillators are disabled. The voltage regulator can also be put either in normal or in low power mode.

The device can be woken up from Stop mode by any of the EXTI line. The EXTI line source can be one of the 16 external lines, the PVD output, the RTC alarm or the USB wakeup.

- **Standby mode**

The Standby mode is used to achieve the lowest power consumption. The internal voltage regulator is switched off so that the entire 1.8 V domain is powered off. The PLL, the HSI RC and the HSE crystal oscillators are also switched off. After entering Standby mode, SRAM and register contents are lost except for registers in the Backup domain and Standby circuitry.

The device exits Standby mode when an external reset (NRST pin), an IWDG reset, a rising edge on the WKUP pin, or an RTC alarm occurs.

Note: The RTC, the IWDG, and the corresponding clock sources are not stopped by entering Stop or Standby mode.



2.3.13 DMA

The flexible 7-channel general-purpose DMA is able to manage memory-to-memory, peripheral-to-memory and memory-to-peripheral transfers. The DMA controller supports circular buffer management avoiding the generation of interrupts when the controller reaches the end of the buffer.

Each channel is connected to dedicated hardware DMA requests, with support for software trigger on each channel. Configuration is made by software and transfer sizes between source and destination are independent.

The DMA can be used with the main peripherals: SPI, I²C, USART, general-purpose and advanced-control timers TIMx and ADC.

2.3.14 RTC (real-time clock) and backup registers

The RTC and the backup registers are supplied through a switch that takes power either on V_{DD} supply when present or through the V_{BAT} pin. The backup registers are ten 16-bit registers used to store 20 bytes of user application data when V_{DD} power is not present.

The real-time clock provides a set of continuously running counters which can be used with suitable software to provide a clock calendar function, and provides an alarm interrupt and a periodic interrupt. It is clocked by a 32.768 kHz external crystal, resonator or oscillator, the internal low-power RC oscillator or the high-speed external clock divided by 128. The internal low-power RC has a typical frequency of 40 kHz. The RTC can be calibrated using an external 512 Hz output to compensate for any natural crystal deviation. The RTC features a 32-bit programmable counter for long-term measurement using the Compare register to generate an alarm. A 20-bit prescaler is used for the time base clock and is by default configured to generate a time base of 1 second from a clock at 32.768 kHz.

2.3.15 Timers and watchdogs

The medium-density STM32F103xx performance line devices include an advanced-control timer, three general-purpose timers, two watchdog timers and a SysTick timer.

[Table 4](#) compares the features of the advanced-control and general-purpose timers.

Table 4. Timer feature comparison

Timer	Counter resolution	Counter type	Prescaler factor	DMA request generation	Capture/compare channels	Complementary outputs
TIM1	16-bit	Up, down, up/down	Any integer between 1 and 65536	Yes	4	Yes
TIM2, TIM3, TIM4	16-bit	Up, down, up/down	Any integer between 1 and 65536	Yes	4	No

Advanced-control timer (TIM1)

The advanced-control timer (TIM1) can be seen as a three-phase PWM multiplexed on 6 channels. It has complementary PWM outputs with programmable inserted dead-times. It



can also be seen as a complete general-purpose timer. The 4 independent channels can be used for

- Input capture
- Output compare
- PWM generation (edge- or center-aligned modes)
- One-pulse mode output

If configured as a general-purpose 16-bit timer, it has the same features as the TIMx timer. If configured as the 16-bit PWM generator, it has full modulation capability (0-100%).

In debug mode, the advanced-control timer counter can be frozen and the PWM outputs disabled to turn off any power switch driven by these outputs.

Many features are shared with those of the general-purpose TIM timers which have the same architecture. The advanced-control timer can therefore work together with the TIM timers via the Timer Link feature for synchronization or event chaining.

General-purpose timers (TIMx)

There are up to three synchronizable general-purpose timers embedded in the STM32F103xx performance line devices. These timers are based on a 16-bit auto-reload up/down counter, a 16-bit prescaler and feature 4 independent channels each for input capture/output compare, PWM or one-pulse mode output. This gives up to 12 input captures/output compares/PWMs on the largest packages.

The general-purpose timers can work together with the advanced-control timer via the Timer Link feature for synchronization or event chaining. Their counter can be frozen in debug mode. Any of the general-purpose timers can be used to generate PWM outputs. They all have independent DMA request generation.

These timers are capable of handling quadrature (incremental) encoder signals and the digital outputs from 1 to 3 hall-effect sensors.

Independent watchdog

The independent watchdog is based on a 12-bit downcounter and 8-bit prescaler. It is clocked from an independent 40 kHz internal RC and as it operates independently of the main clock, it can operate in Stop and Standby modes. It can be used either as a watchdog to reset the device when a problem occurs, or as a free-running timer for application timeout management. It is hardware- or software-configurable through the option bytes. The counter can be frozen in debug mode.

Window watchdog

The window watchdog is based on a 7-bit downcounter that can be set as free-running. It can be used as a watchdog to reset the device when a problem occurs. It is clocked from the main clock. It has an early warning interrupt capability and the counter can be frozen in debug mode.



SysTick timer

This timer is dedicated for OS, but could also be used as a standard downcounter. It features:

- A 24-bit downcounter
- Autoreload capability
- Maskable system interrupt generation when the counter reaches 0
- Programmable clock source

2.3.16 I²C bus

Up to two I²C bus interfaces can operate in multimaster and slave modes. They can support standard and fast modes.

They support dual slave addressing (7-bit only) and both 7/10-bit addressing in master mode. A hardware CRC generation/verification is embedded.

They can be served by DMA and they support SM Bus 2.0/PM Bus.

2.3.17 Universal synchronous/asynchronous receiver transmitter (USART)

One of the USART interfaces is able to communicate at speeds of up to 4.5 Mbit/s. The other available interfaces communicate at up to 2.25 Mbit/s. They provide hardware management of the CTS and RTS signals, IrDA SIR ENDEC support, are ISO 7816 compliant and have LIN Master/Slave capability.

All USART interfaces can be served by the DMA controller.

2.3.18 Serial peripheral interface (SPI)

Up to two SPIs are able to communicate up to 18 Mbits/s in slave and master modes in full-duplex and simplex communication modes. The 3-bit prescaler gives 8 master mode frequencies and the frame is configurable to 8 bits or 16 bits. The hardware CRC generation/verification supports basic SD Card/MMC modes.

Both SPIs can be served by the DMA controller.

2.3.19 Controller area network (CAN)

The CAN is compliant with specifications 2.0A and B (active) with a bit rate up to 1 Mbit/s. It can receive and transmit standard frames with 11-bit identifiers as well as extended frames with 29-bit identifiers. It has three transmit mailboxes, two receive FIFOs with 3 stages and 14 scalable filter banks.

2.3.20 Universal serial bus (USB)

The STM32F103xx performance line embeds a USB device peripheral compatible with the USB full-speed 12 Mbs. The USB interface implements a full-speed (12 Mbit/s) function interface. It has software-configurable endpoint setting and suspend/resume support. The dedicated 48 MHz clock is generated from the internal main PLL (the clock source must use a HSE crystal oscillator).



2.3.21 GPIOs (general-purpose inputs/outputs)

Each of the GPIO pins can be configured by software as output (push-pull or open-drain), as input (with or without pull-up or pull-down) or as peripheral alternate function. Most of the GPIO pins are shared with digital or analog alternate functions. All GPIOs are high-current-capable except for analog inputs.

The I/Os alternate function configuration can be locked if needed following a specific sequence in order to avoid spurious writing to the I/Os registers.

I/Os on APB2 with up to 18 MHz toggling speed

2.3.22 ADC (analog-to-digital converter)

Two 12-bit analog-to-digital converters are embedded into STM32F103xx performance line devices and each ADC shares up to 16 external channels, performing conversions in single-shot or scan modes. In scan mode, automatic conversion is performed on a selected group of analog inputs.

Additional logic functions embedded in the ADC interface allow:

- Simultaneous sample and hold
- Interleaved sample and hold
- Single shunt

The ADC can be served by the DMA controller.

An analog watchdog feature allows very precise monitoring of the converted voltage of one, some or all selected channels. An interrupt is generated when the converted voltage is outside the programmed thresholds.

The events generated by the general-purpose timers (TIMx) and the advanced-control timer (TIM1) can be internally connected to the ADC start trigger, injection trigger, and DMA trigger respectively, to allow the application to synchronize A/D conversion and timers.

2.3.23 Temperature sensor

The temperature sensor has to generate a voltage that varies linearly with temperature. The conversion range is between $2\text{ V} < V_{\text{DDA}} < 3.6\text{ V}$. The temperature sensor is internally connected to the ADC12_IN16 input channel which is used to convert the sensor output voltage into a digital value.

2.3.24 Serial wire JTAG debug port (SWJ-DP)

The ARM SWJ-DP Interface is embedded. and is a combined JTAG and serial wire debug port that enables either a serial wire debug or a JTAG probe to be connected to the target. The JTAG TMS and TCK pins are shared with SWDIO and SWCLK, respectively, and a specific sequence on the TMS pin is used to switch between JTAG-DP and SW-DP.



Figure 1. STM32F103xx performance line block diagram

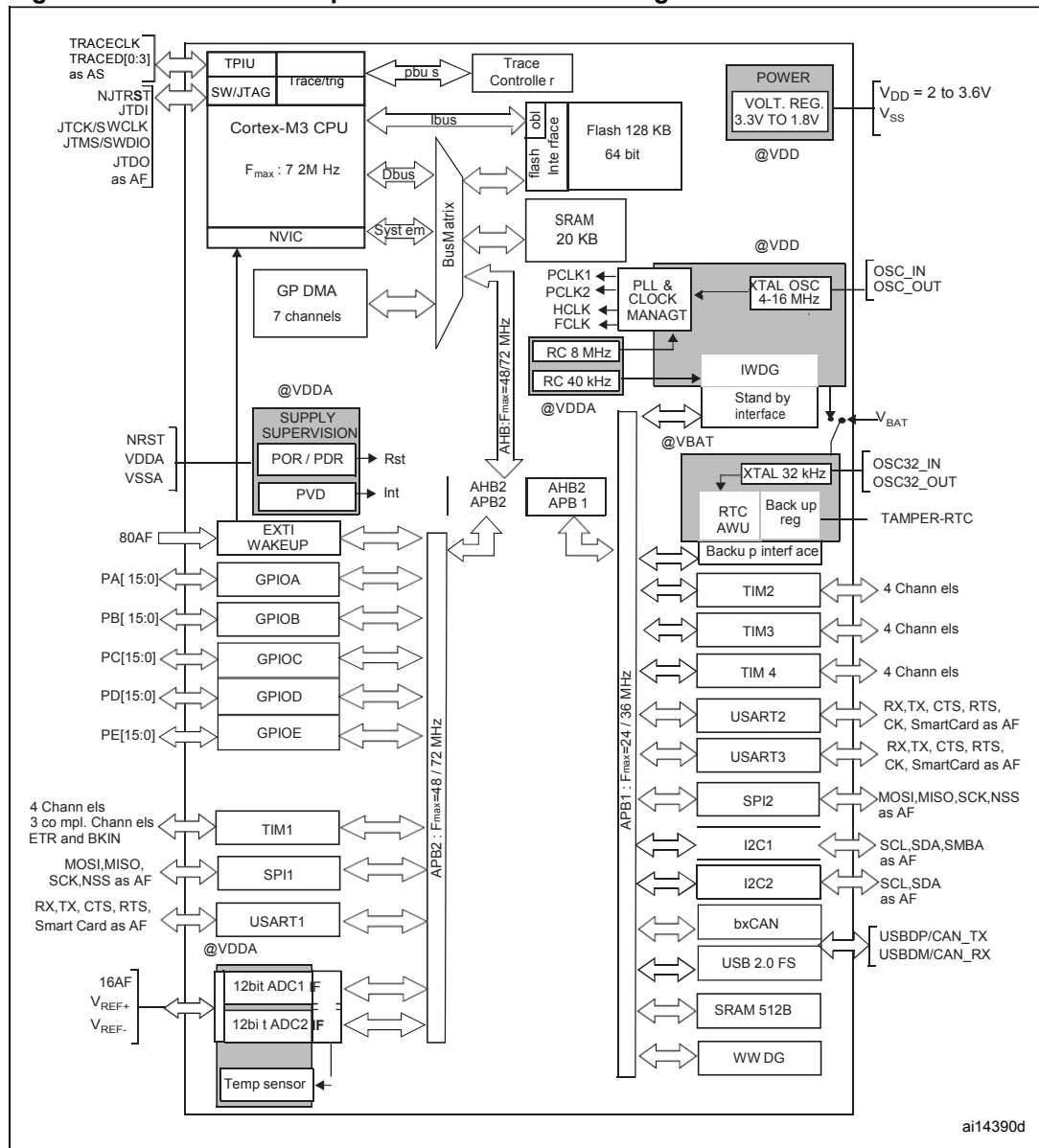

1. $T_A = -40\text{ }^{\circ}\text{C}$ to $+105\text{ }^{\circ}\text{C}$ (junction temperature up to $125\text{ }^{\circ}\text{C}$).
2. AF = alternate function on I/O port pin.



Figure 2. Clock tree

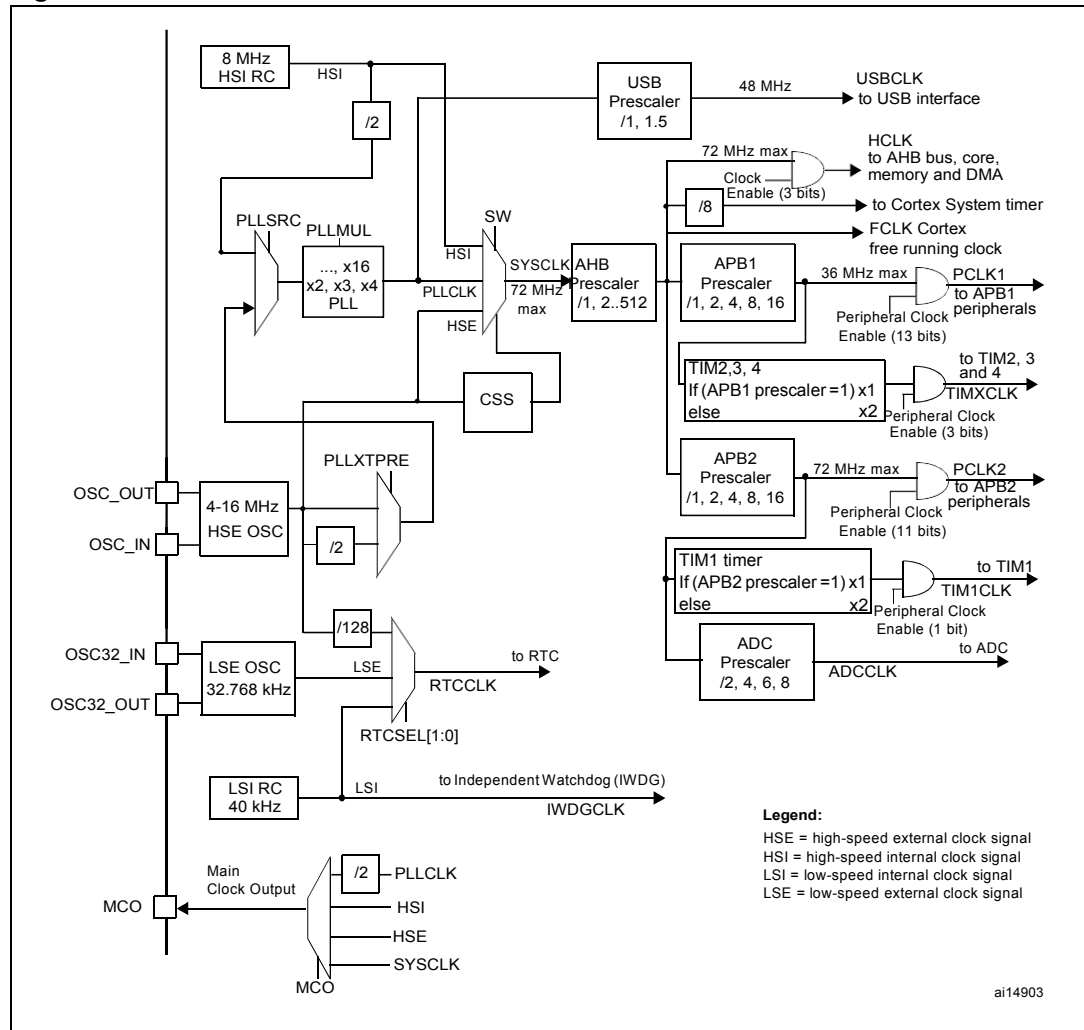

1. When the HSI is used as a PLL clock input, the maximum system clock frequency that can be achieved is 64 MHz.
2. For the USB function to be available, both HSE and PLL must be enabled, with the CPU running at either 48 MHz or 72 MHz.
3. To have an ADC conversion time of 1 μ s, APB2 must be at 14 MHz, 28 MHz or 56 MHz.

20/91

Doc ID 13587 Rev 10



3 Pinouts and pin description

Figure 3. STM32F103xx performance line LFBGA100 ballout

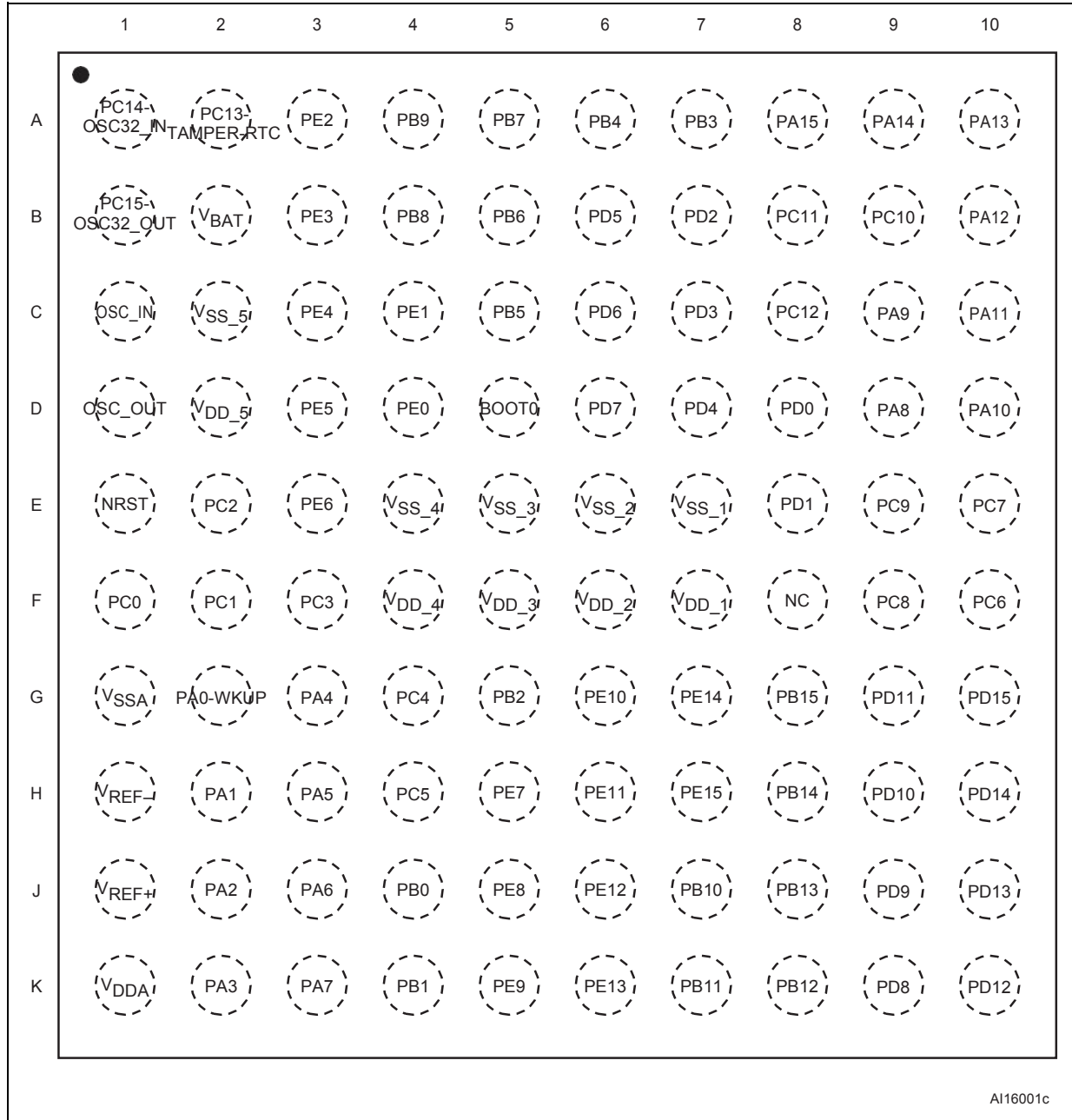

AI16001c



Figure 4. STM32F103xx performance line LQFP100 pinout

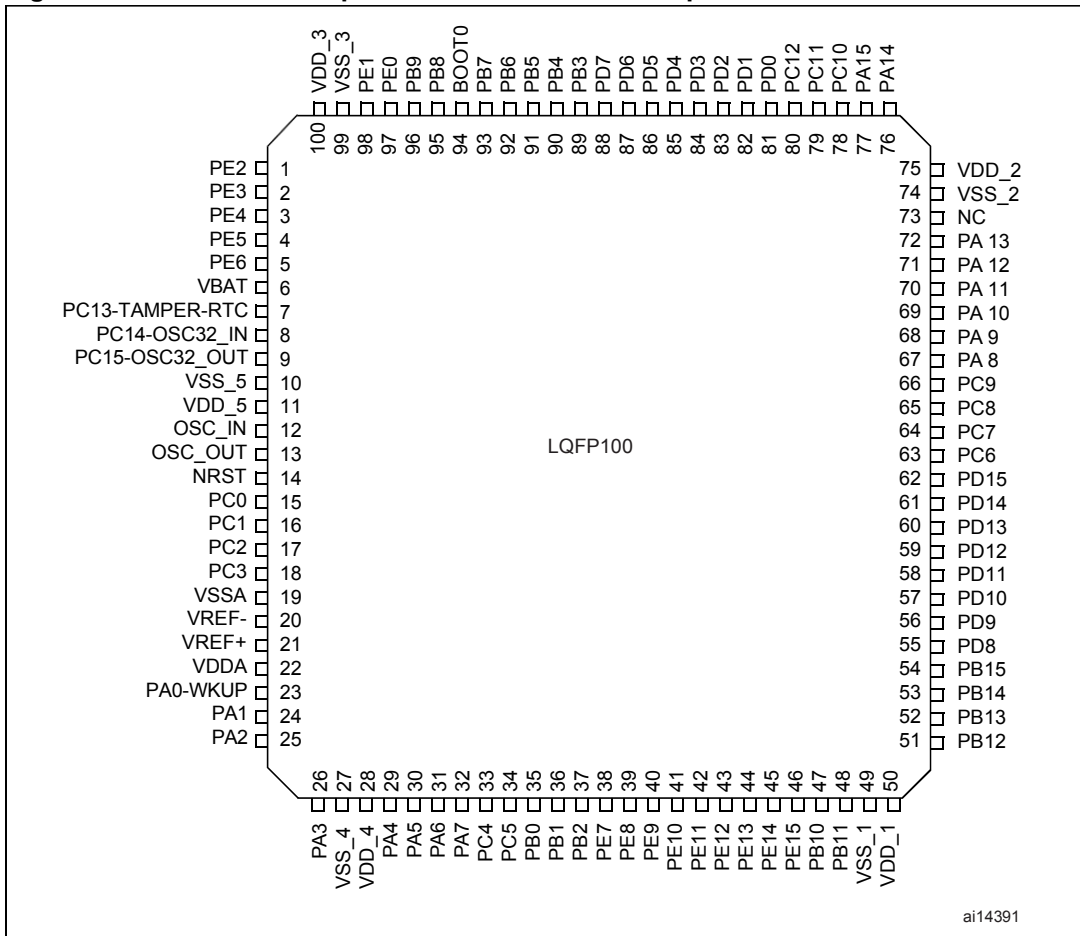

ai14391

Figure 4. STM32F103xx performance line LQFP100 pinout

22/91

Doc ID 13587 Rev 10



Figure 5. STM32F103xx performance line LQFP64 pinout

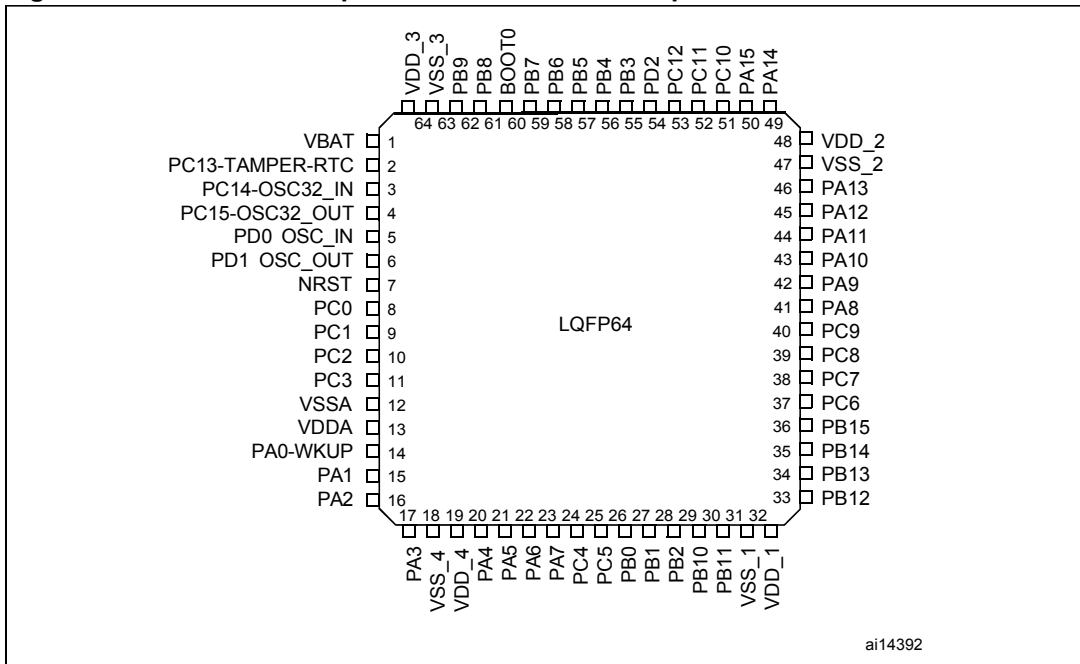



Figure 5. STM32F103xx performance line LQFP64 pinout
Doc ID 13587 Rev 10



Figure 6. STM32F103xx performance line TFBGA64 ballout

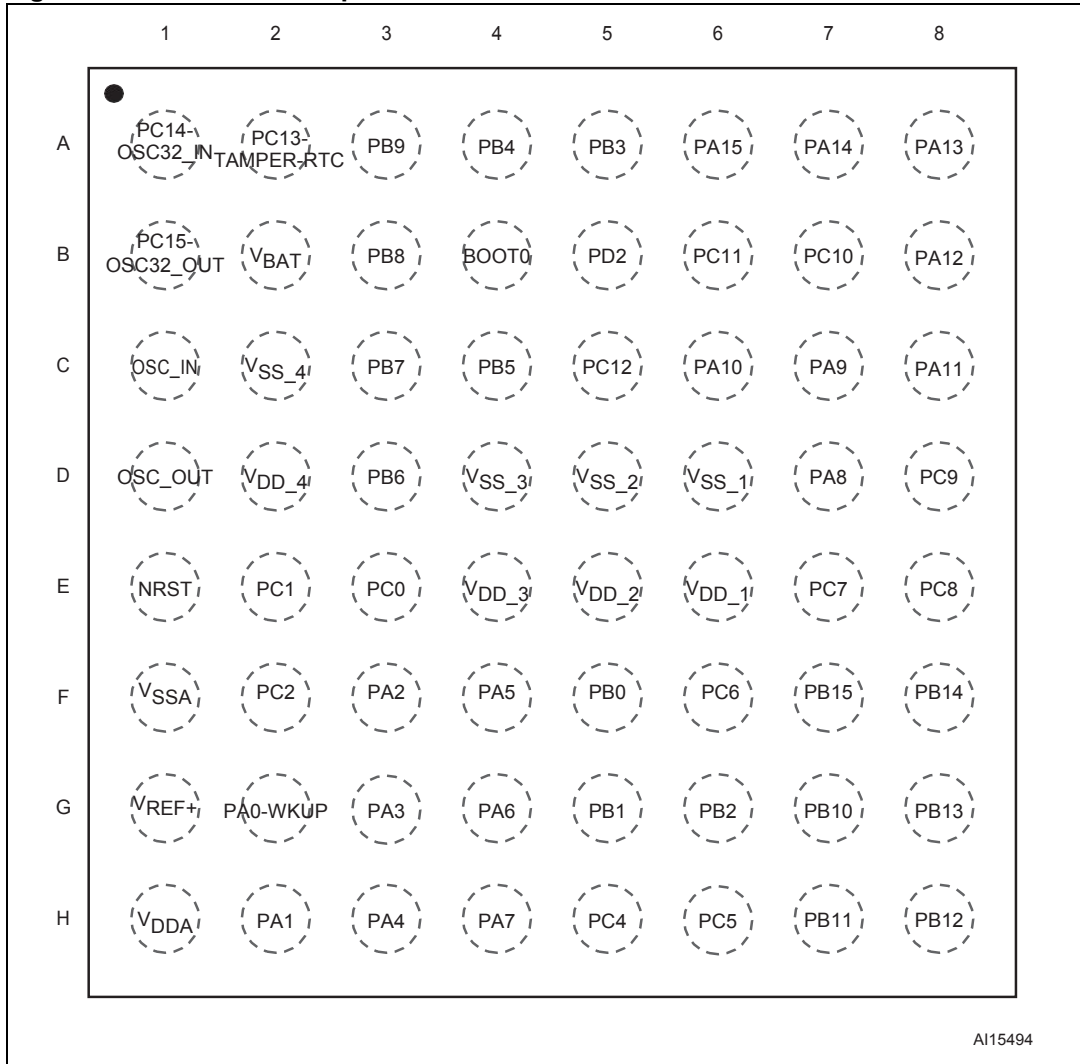

Figure 6. STM32F103xx performance line TFBGA64 ballout

24/91

Doc ID 13587 Rev 10



Figure 7. STM32F103xx performance line LQFP48 pinout

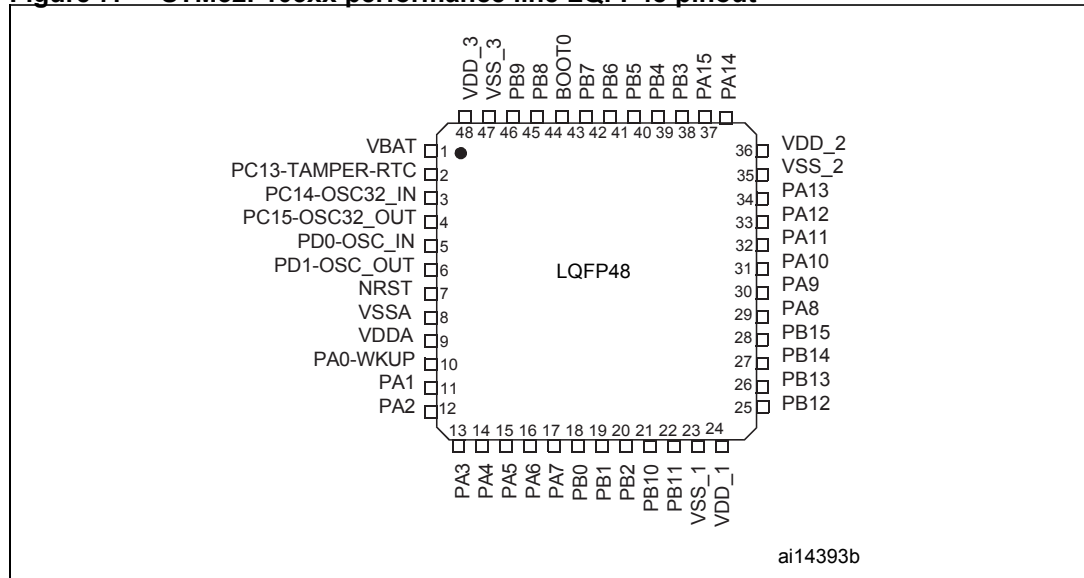

Figure 8. STM32F103xx Performance Line VFQFPN36 pinout

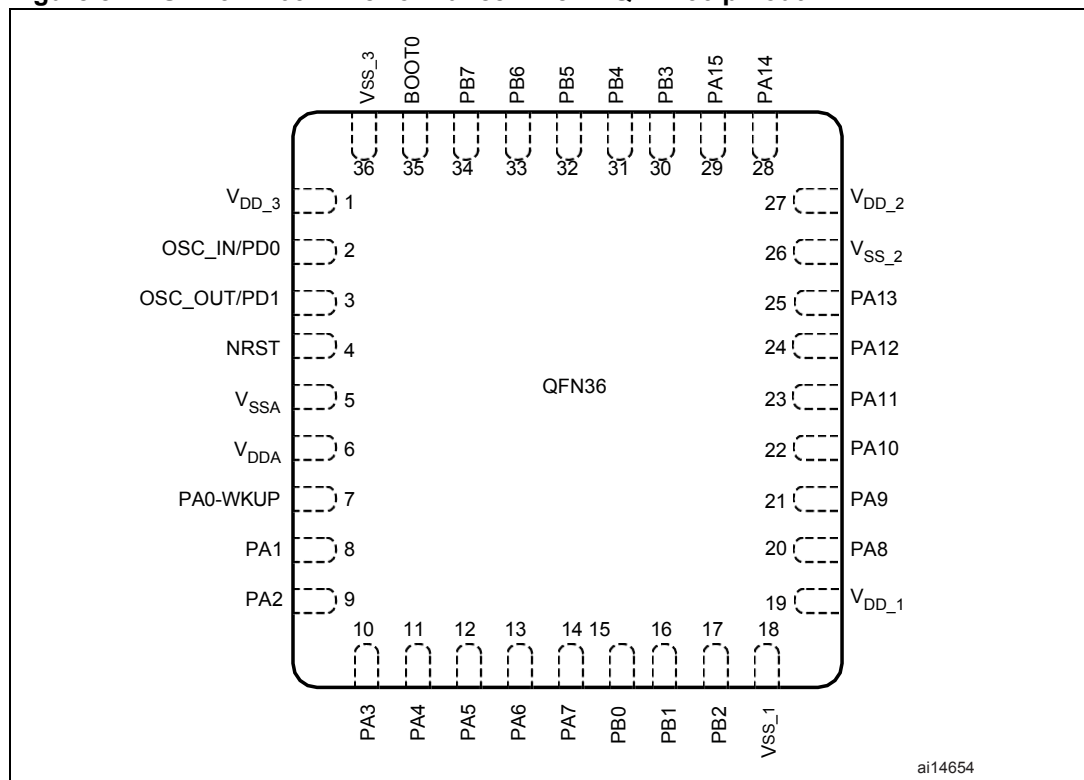



Figure 7. STM32F103xx performance line LQFP48 pinout

Doc ID 13587 Rev 10

25/91



Table 5. Medium-density STM32F103xx pin definitions

Pins						Pin name	Type ⁽¹⁾	I / O Level ⁽²⁾	Main function ⁽³⁾ (after reset)	Alternate functions	
LFPGA100	LQFP48	TFBGA64	LQFP64	LQFP100	VQFPN36					Default	Remap
A3	-		-	1	-	PE2	I/O	FT	PE2	TRACECK	
B3	-		-	2	-	PE3	I/O	FT	PE3	TRACED0	
C3	-		-	3	-	PE4	I/O	FT	PE4	TRACED1	
D3	-		-	4	-	PE5	I/O	FT	PE5	TRACED2	
E3	-		-	5	-	PE6	I/O	FT	PE6	TRACED3	
B2	1	B2	1	6	-	V _{BAT}	S		V _{BAT}		
A2	2	A2	2	7	-	PC13-TAMPER-RTC ⁽⁴⁾	I/O		PC13 ⁽⁵⁾	TAMPER-RTC	
A1	3	A1	3	8	-	PC14-OSC32_IN ⁽⁴⁾	I/O		PC14 ⁽⁵⁾	OSC32_IN	
B1	4	B1	4	9	-	PC15-OSC32_OUT ⁽⁴⁾	I/O		PC15 ⁽⁵⁾	OSC32_OUT	
C2	-	-	-	10	-	V _{SS_5}	S		V _{SS_5}		
D2	-	-	-	11	-	V _{DD_5}	S		V _{DD_5}		
C1	5	C1	5	12	2	OSC_IN	I		OSC_IN		
D1	6	D1	6	13	3	OSC_OUT	O		OSC_OUT		
E1	7	E1	7	14	4	NRST	I/O		NRST		
F1	-	E3	8	15	-	PC0	I/O		PC0	ADC12_IN10	
F2	-	E2	9	16	-	PC1	I/O		PC1	ADC12_IN11	
E2	-	F2	10	17	-	PC2	I/O		PC2	ADC12_IN12	
F3	-	- ⁽⁶⁾	11	18	-	PC3	I/O		PC3	ADC12_IN13	
G1	8	F1	12	19	5	V _{SSA}	S		V _{SSA}		
H1	-	-	-	20	-	V _{REF-}	S		V _{REF-}		
J1	-	G1 ⁽⁶⁾	-	21	-	V _{REF+}	S		V _{REF+}		
K1	9	H1	13	22	6	V _{DDA}	S		V _{DDA}		
G2	10	G2	14	23	7	PA0-WKUP	I/O		PA0	WKUP/ USART2_CTS ⁽⁷⁾ / ADC12_IN0/ TIM2_CH1_ETR ⁽⁷⁾	
H2	11	H2	15	24	8	PA1	I/O		PA1	USART2_RTS ⁽⁷⁾ / ADC12_IN1/ TIM2_CH2 ⁽⁷⁾	
J2	12	F3	16	25	9	PA2	I/O		PA2	USART2_TX ⁽⁷⁾ / ADC12_IN2/ TIM2_CH3 ⁽⁷⁾	



Table 5. Medium-density STM32F103xx pin definitions (continued)

Pins						Pin name	Type ⁽¹⁾	I/O Level ⁽²⁾	Main function ⁽³⁾ (after reset)	Alternate functions	
LFBGA100	LQFP48	TFBGA64	LQFP64	LQFP100	VFQFPN36					Default	Remap
K2	13	G3	17	26	10	PA3	I/O		PA3	USART2_RX ⁽⁷⁾ / ADC12_IN3/ TIM2_CH4 ⁽⁷⁾	
E4	-	C2	18	27	-	V _{SS_4}	S		V _{SS_4}		
F4	-	D2	19	28	-	V _{DD_4}	S		V _{DD_4}		
G3	14	H3	20	29	11	PA4	I/O		PA4	SPI1_NSS ⁽⁷⁾ / USART2_CK ⁽⁷⁾ / ADC12_IN4	
H3	15	F4	21	30	12	PA5	I/O		PA5	SPI1_SCK ⁽⁷⁾ / ADC12_IN5	
J3	16	G4	22	31	13	PA6	I/O		PA6	SPI1_MISO ⁽⁷⁾ / ADC12_IN6/ TIM3_CH1 ⁽⁷⁾	TIM1_BKIN
K3	17	H4	23	32	14	PA7	I/O		PA7	SPI1_MOSI ⁽⁷⁾ / ADC12_IN7/ TIM3_CH2 ⁽⁷⁾	TIM1_CH1N
G4	-	H5	24	33		PC4	I/O		PC4	ADC12_IN14	
H4	-	H6	25	34		PC5	I/O		PC5	ADC12_IN15	
J4	18	F5	26	35	15	PB0	I/O		PB0	ADC12_IN8/ TIM3_CH3 ⁽⁷⁾	TIM1_CH2N
K4	19	G5	27	36	16	PB1	I/O		PB1	ADC12_IN9/ TIM3_CH4 ⁽⁷⁾	TIM1_CH3N
G5	20	G6	28	37	17	PB2	I/O	FT	PB2/BOOT1		
H5	-	-	-	38	-	PE7	I/O	FT	PE7		TIM1_ETR
J5	-	-	-	39	-	PE8	I/O	FT	PE8		TIM1_CH1N
K5	-	-	-	40	-	PE9	I/O	FT	PE9		TIM1_CH1
G6	-	-	-	41	-	PE10	I/O	FT	PE10		TIM1_CH2N
H6	-	-	-	42	-	PE11	I/O	FT	PE11		TIM1_CH2
J6	-	-	-	43	-	PE12	I/O	FT	PE12		TIM1_CH3N
K6	-	-	-	44	-	PE13	I/O	FT	PE13		TIM1_CH3
G7	-	-	-	45	-	PE14	I/O	FT	PE14		TIM1_CH4
H7	-	-	-	46	-	PE15	I/O	FT	PE15		TIM1_BKIN
J7	21	G7	29	47	-	PB10	I/O	FT	PB10	I2C2_SCL/ USART3_TX ⁽⁷⁾	TIM2_CH3
K7	22	H7	30	48	-	PB11	I/O	FT	PB11	I2C2_SDA/ USART3_RX ⁽⁷⁾	TIM2_CH4

E7	23	D6	31	49	18	V _{SS_1}	S	V _{SS_1}		
----	----	----	----	----	----	-------------------	---	-------------------	--	--

Table 5. Medium-density STM32F103xx pin definitions (continued)



Table 5. Medium-density STM32F103xx pin definitions (continued)

Pins						Pin name	Type ⁽¹⁾	I / O Level ⁽²⁾	Main function ⁽³⁾ (after reset)	Alternate functions	
LFPGA100	LQFP48	TFBGA64	LQFP64	LQFP100	VFQFPN36					Default	Remap
F7	24	E6	32	50	19	V _{DD_1}	S		V _{DD_1}		
K8	25	H8	33	51	-	PB12	I/O	FT	PB12	SPI2_NSS/ I2C2_SMBAL/ USART3_CK ⁽⁷⁾ / TIM1_BKIN ⁽⁷⁾	
J8	26	G8	34	52	-	PB13	I/O	FT	PB13	SPI2_SCK/ USART3_CTS ⁽⁷⁾ / TIM1_CH1N ⁽⁷⁾	
H8	27	F8	35	53	-	PB14	I/O	FT	PB14	SPI2_MISO/ USART3_RTS ⁽⁷⁾ / TIM1_CH2N ⁽⁷⁾	
G8	28	F7	36	54	-	PB15	I/O	FT	PB15	SPI2_MOSI/ TIM1_CH3N ⁽⁷⁾	
K9	-	-	-	55	-	PD8	I/O	FT	PD8		USART3_TX
J9	-	-	-	56	-	PD9	I/O	FT	PD9		USART3_RX
H9	-	-	-	57	-	PD10	I/O	FT	PD10		USART3_CK
G9	-	-	-	58	-	PD11	I/O	FT	PD11		USART3_CTS
K10	-	-	-	59	-	PD12	I/O	FT	PD12		TIM4_CH1 / USART3_RTS
J10	-	-	-	60	-	PD13	I/O	FT	PD13		TIM4_CH2
H10	-	-	-	61	-	PD14	I/O	FT	PD14		TIM4_CH3
G10	-	-	-	62	-	PD15	I/O	FT	PD15		TIM4_CH4
F10	-	F6	37	63	-	PC6	I/O	FT	PC6		TIM3_CH1
E10	-	E7	38	64	-	PC7	I/O	FT	PC7		TIM3_CH2
F9	-	E8	39	65	-	PC8	I/O	FT	PC8		TIM3_CH3
E9	-	D8	40	66	-	PC9	I/O	FT	PC9		TIM3_CH4
D9	29	D7	41	67	20	PA8	I/O	FT	PA8	USART1_CK/ TIM1_CH1 ⁽⁷⁾ /MCO	
C9	30	C7	42	68	21	PA9	I/O	FT	PA9	USART1_TX ⁽⁷⁾ / TIM1_CH2 ⁽⁷⁾	
D10	31	C6	43	69	22	PA10	I/O	FT	PA10	USART1_RX ⁽⁷⁾ / TIM1_CH3 ⁽⁷⁾	
C10	32	C8	44	70	23	PA11	I/O	FT	PA11	USART1_CTS/ CANRX ⁽⁷⁾ /USBDM TIM1_CH4 ⁽⁷⁾	

B10	33	B8	45	71	24	PA14	I/O	FT	PA12	USART1_RTS/ CAN TX ⁽⁷⁾ // USBDP TIM1_ETR ⁽⁷⁾	
-----	----	----	----	----	----	------	-----	----	------	--	--



Table 5. Medium-density STM32F103xx pin definitions (continued)

Pins						Pin name	Type ⁽¹⁾	I / O Level ⁽²⁾	Main function ⁽³⁾ (after reset)	Alternate functions	
LFPGA100	LQFP48	TFBGA64	LQFP64	LQFP100	VFQFPN36					Default	Remap
A10	34	A8	46	72	25	PA13	I/O	FT	JTMS/SWDIO		PA13
F8	-	-	-	73	-	Not connected					
E6	35	D5	47	74	26	V _{SS_2}	S		V _{SS_2}		
F6	36	E5	48	75	27	V _{DD_2}	S		V _{DD_2}		
A9	37	A7	49	76	28	PA14	I/O	FT	JTCK/SWCLK		PA14
A8	38	A6	50	77	29	PA15	I/O	FT	JTDI		TIM2_CH1_ETR/ PA15/SPI1_NSS
B9	-	B7	51	78		PC10	I/O	FT	PC10		USART3_TX
B8	-	B6	52	79		PC11	I/O	FT	PC11		USART3_RX
C8	-	C5	53	80		PC12	I/O	FT	PC12		USART3_CK
D8	5	C1	5	81	2	PD0	I/O	FT	OSC_IN ⁽⁸⁾		CANRX
E8	6	D1	6	82	3	PD1	I/O	FT	OSC_OUT ⁽⁸⁾		CANTX
B7		B5	54	83	-	PD2	I/O	FT	PD2	TIM3_ETR	
C7	-	-	-	84	-	PD3	I/O	FT	PD3		USART2_CTS
D7	-	-	-	85	-	PD4	I/O	FT	PD4		USART2_RTS
B6	-	-	-	86	-	PD5	I/O	FT	PD5		USART2_TX
C6	-	-	-	87	-	PD6	I/O	FT	PD6		USART2_RX
D6	-	-	-	88	-	PD7	I/O	FT	PD7		USART2_CK
A7	39	A5	55	89	30	PB3	I/O	FT	JTDO		TIM2_CH2 / PB3 TRACESWO SPI1_SCK
A6	40	A4	56	90	31	PB4	I/O	FT	JNTRST		TIM3_CH1/ PB4/ SPI1_MISO
C5	41	C4	57	91	32	PB5	I/O		PB5	I2C1_SMBAL	TIM3_CH2 / SPI1_MOSI
B5	42	D3	58	92	33	PB6	I/O	FT	PB6	I2C1_SCL ⁽⁷⁾ / TIM4_CH1 ⁽⁷⁾	USART1_TX
A5	43	C3	59	93	34	PB7	I/O	FT	PB7	I2C1_SDA ⁽⁷⁾ / TIM4_CH2 ⁽⁷⁾	USART1_RX
D5	44	B4	60	94	35	BOOT0	I		BOOT0		
B4	45	B3	61	95	-	PB8	I/O	FT	PB8	TIM4_CH3 ⁽⁷⁾	I2C1_SCL / CANRX
A4	46	A3	62	96	-	PB9	I/O	FT	PB9	TIM4_CH4 ⁽⁷⁾	I2C1_SDA/ CANTX

Table 5. Medium-density STM32F103xx pin definitions (continued)



Doc ID 13587 Rev 10

29/91



Table 5. Medium-density STM32F103xx pin definitions (continued)

Pins						Pin name	Type ⁽¹⁾	I / O Level ⁽²⁾	Main function ⁽³⁾ (after reset)	Alternate functions	
LFBGA100	LQFP48	TFBGA64	LQFP64	LQFP100	VFQFPN36					Default	Remap
D4	-	-	-	97	-	PE0	I/O	FT	PE0	TIM4_ETR	
C4	-	-	-	98	-	PE1	I/O	FT	PE1		
E5	47	D4	63	99	36	V _{SS_3}	S		V _{SS_3}		
F5	48	E4	64	100	1	V _{DD_3}	S		V _{DD_3}		

1. I = input, O = output, S = supply, HiZ = high impedance.
2. FT = 5 V tolerant.
3. Function availability depends on the chosen device. For devices having reduced peripheral counts, it is always the lower number of peripheral that is included. For example, if a device has only one SPI and two USARTs, they will be called SPI1 and USART1 & USART2, respectively. Refer to [Table 2 on page 10](#).
4. PC13, PC14 and PC15 are supplied through the power switch and since the switch only sinks a limited amount of current (3 mA), the use of GPIOs PC13 to PC15 is restricted: only one I/O at a time can be used as an output, the speed has to be limited to 2 MHz with a maximum load of 30 pF and these I/Os must not be used as a current source (e.g. to drive an LED).
5. Main function after the first backup domain power-up. Later on, it depends on the contents of the Backup registers even after reset (because these registers are not reset by the main reset). For details on how to manage these IOs, refer to the Battery backup domain and BKP register description sections in the STM32F10xxx reference manual, available from the STMicroelectronics website: www.st.com.
6. Unlike in the LQFP64 package, there is no PC3 in the TFBGA64 package. The V_{REF+} functionality is provided instead.
7. This alternate function can be remapped by software to some other port pins (if available on the used package). For more details, refer to the Alternate function I/O and debug configuration section in the STM32F10xxx reference manual, available from the STMicroelectronics website: www.st.com.
8. The pins number 2 and 3 in the VFQFPN36 package, 5 and 6 in the LQFP48 and LQFP64 packages, and C1 and C2 in the TFBGA64 package are configured as OSC_IN/OSC_OUT after reset, however the functionality of PD0 and PD1 can be remapped by software on these pins. For the LQFP100 package, PD0 and PD1 are available by default, so there is no need for remapping. For more details, refer to the Alternate function I/O and debug configuration section in the STM32F10xxx reference manual.
The use of PD0 and PD1 in output mode is limited as they can only be used at 50 MHz in output mode.

Table 5. Medium-density STM32F103xx pin definitions (continued)

30/91

Doc ID 13587 Rev 10



4 Memory mapping

The memory map is shown in *Figure 9*.

Figure 9. Memory map

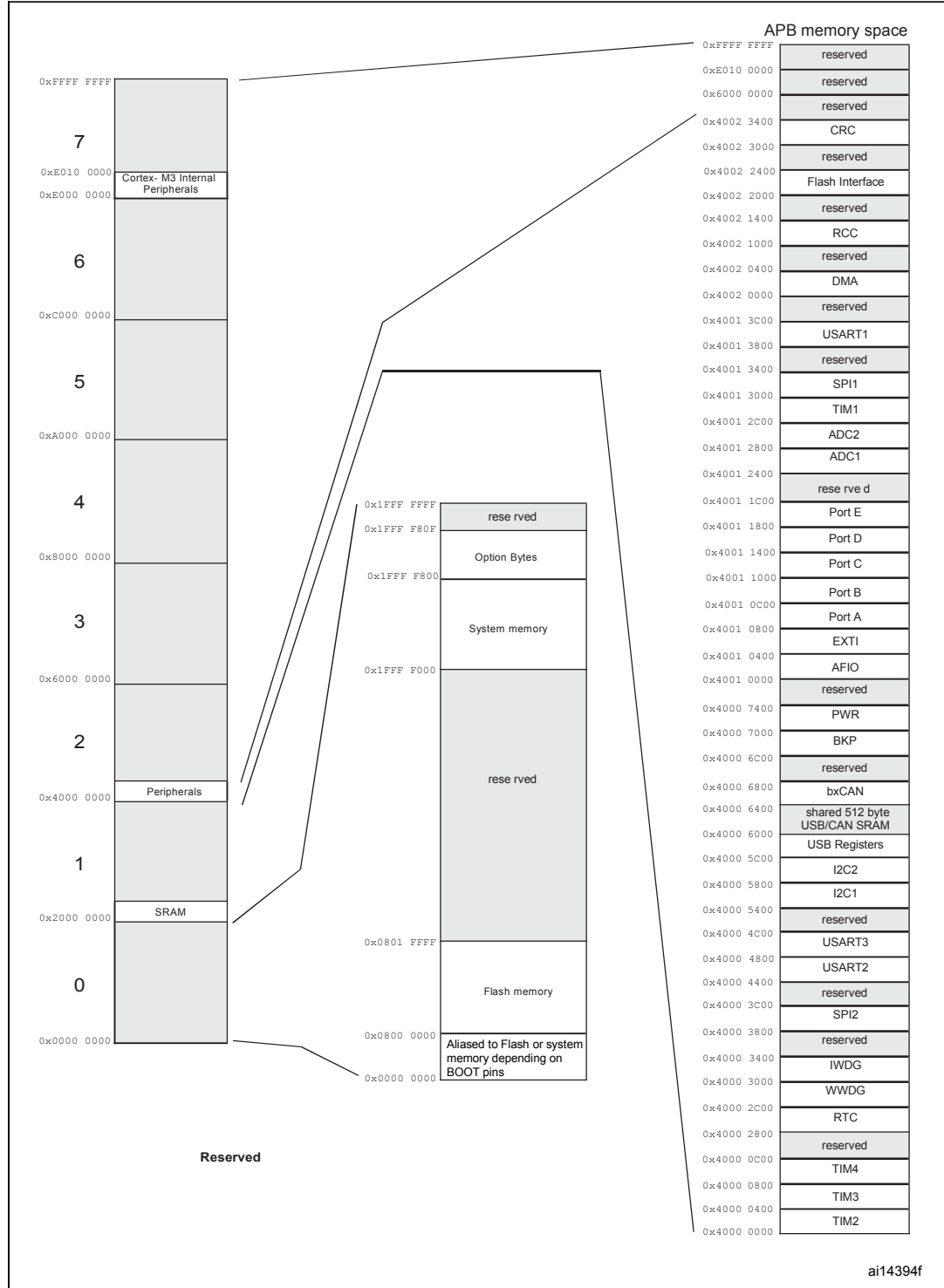



5 Electrical characteristics

5.1 Parameter conditions

Unless otherwise specified, all voltages are referenced to V_{SS} .

5.1.1 Minimum and maximum values

Unless otherwise specified the minimum and maximum values are guaranteed in the worst conditions of ambient temperature, supply voltage and frequencies by tests in production on 100% of the devices with an ambient temperature at $T_A = 25\text{ °C}$ and $T_A = T_{Amax}$ (given by the selected temperature range).

Data based on characterization results, design simulation and/or technology characteristics are indicated in the table footnotes and are not tested in production. Based on characterization, the minimum and maximum values refer to sample tests and represent the mean value plus or minus three times the standard deviation ($\text{mean} \pm 3\sigma$).

5.1.2 Typical values

Unless otherwise specified, typical data are based on $T_A = 25\text{ °C}$, $V_{DD} = 3.3\text{ V}$ (for the $2\text{ V} \leq V_{DD} \leq 3.6\text{ V}$ voltage range). They are given only as design guidelines and are not tested.

Typical ADC accuracy values are determined by characterization of a batch of samples from a standard diffusion lot over the full temperature range, where 95% of the devices have an error less than or equal to the value indicated ($\text{mean} \pm 2\sigma$).

5.1.3 Typical curves

Unless otherwise specified, all typical curves are given only as design guidelines and are not tested.

5.1.4 Loading capacitor

The loading conditions used for pin parameter measurement are shown in [Figure 10](#).

5.1.5 Pin input voltage

The input voltage measurement on a pin of the device is described in [Figure 11](#).



Figure 10. Pin loading conditions

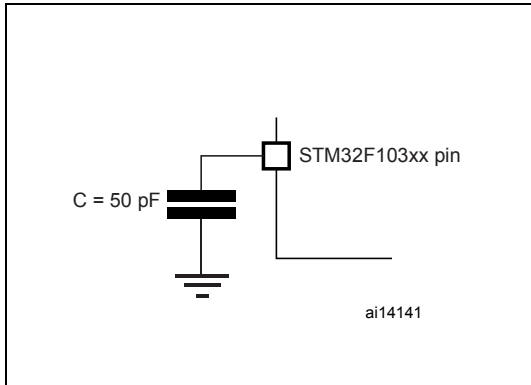
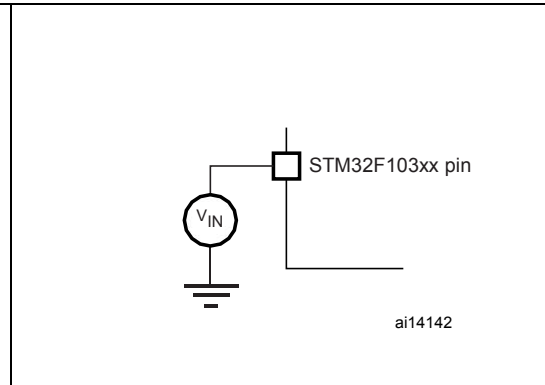
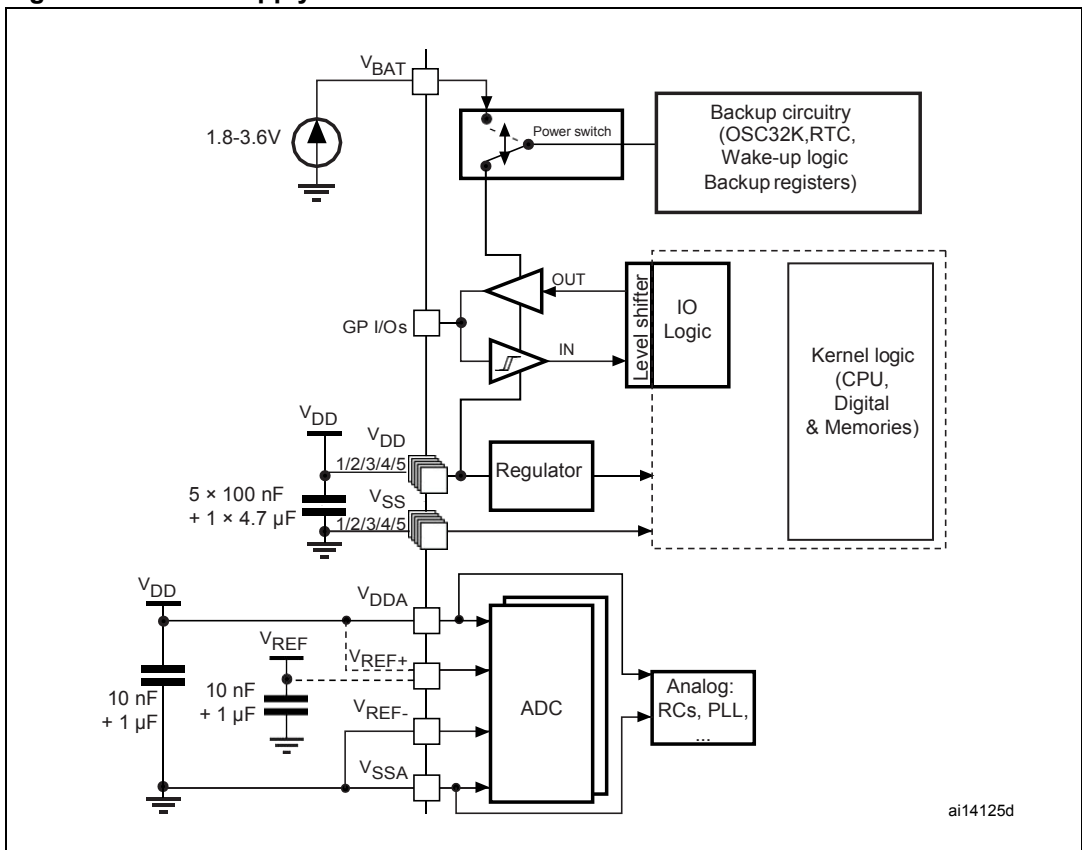

Figure 11. Pin input voltage



5.1.6 Power supply scheme

Figure 12. Power supply scheme



Caution: In [Figure 12](#), the $4.7 \text{ }\mu\text{F}$ capacitor must be connected to V_{DD3} .



5.1.7 Current consumption measurement

Figure 13. Current consumption measurement scheme

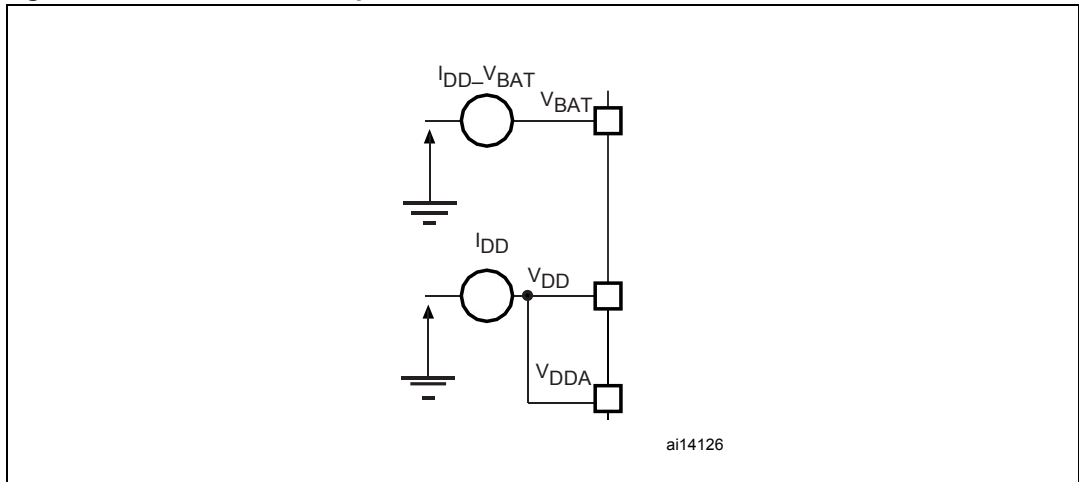

5.2 Absolute maximum ratings

Stresses above the absolute maximum ratings listed in [Table 6: Voltage characteristics](#), [Table 7: Current characteristics](#), and [Table 8: Thermal characteristics](#) may cause permanent damage to the device. These are stress ratings only and functional operation of the device at these conditions is not implied. Exposure to maximum rating conditions for extended periods may affect device reliability.

Table 6. Voltage characteristics

Symbol	Ratings	Min	Max	Unit
V_{DD-VSS}	External main supply voltage (including V_{DDA} and V_{DD}) ⁽¹⁾	-0.3	4.0	V
V_{IN}	Input voltage on five volt tolerant pin ⁽²⁾	$V_{SS} - 0.3$	+5.5	
	Input voltage on any other pin ⁽²⁾	$V_{SS} - 0.3$	$V_{DD} + 0.3$	
$ \Delta V_{DDx} $	Variations between different V_{DD} power pins		50	mV
$ V_{SSx} - V_{SS} $	Variations between all the different ground pins		50	
$V_{ESD(HBM)}$	Electrostatic discharge voltage (human body model)	see Section 5.3.11: Absolute maximum ratings (electrical sensitivity)		

1. All main power (V_{DD} , V_{DDA}) and ground (V_{SS} , V_{SSA}) pins must always be connected to the external power supply, in the permitted range.
2. $I_{INJ(PIN)}$ must never be exceeded (see [Table 7: Current characteristics](#)). This is implicitly insured if V_{IN} maximum is respected. If V_{IN} maximum cannot be respected, the injection current must be limited externally to the $I_{INJ(PIN)}$ value. A positive injection is induced by $V_{IN} > V_{INmax}$ while a negative injection is induced by $V_{IN} < V_{SS}$.



Table 7. Current characteristics

Symbol	Ratings	Max.	Unit
I_{VDD}	Total current into V_{DD}/V_{DDA} power lines (source) ⁽¹⁾	150	mA
I_{VSS}	Total current out of V_{SS} ground lines (sink) ⁽¹⁾	150	
I_{IO}	Output current sunk by any I/O and control pin	25	
	Output current source by any I/Os and control pin	- 25	
$I_{INJ(PIN)}$ ⁽²⁾⁽³⁾	Injected current on NRST pin	± 5	
	Injected current on HSE OSC_IN and LSE OSC_IN pins	± 5	
	Injected current on any other pin ⁽⁴⁾	± 5	
$\Sigma I_{INJ(PIN)}$ ⁽²⁾	Total injected current (sum of all I/O and control pins) ⁽⁴⁾	± 25	

1. All main power (V_{DD} , V_{DDA}) and ground (V_{SS} , V_{SSA}) pins must always be connected to the external power supply, in the permitted range.
2. $I_{INJ(PIN)}$ must never be exceeded. This is implicitly insured if V_{IN} maximum is respected. If V_{IN} maximum cannot be respected, the injection current must be limited externally to the $I_{INJ(PIN)}$ value. A positive injection is induced by $V_{IN} > V_{DD}$ while a negative injection is induced by $V_{IN} < V_{SS}$.
3. Negative injection disturbs the analog performance of the device. See note in [Section 5.3.17: 12-bit ADC characteristics](#).
4. When several inputs are submitted to a current injection, the maximum $\Sigma I_{INJ(PIN)}$ is the absolute sum of the positive and negative injected currents (instantaneous values). These results are based on characterization with $\Sigma I_{INJ(PIN)}$ maximum current injection on four I/O port pins of the device.

Table 8. Thermal characteristics

Symbol	Ratings	Value	Unit
T_{STG}	Storage temperature range	-65 to +150	°C
T_J	Maximum junction temperature	150	°C

5.3 Operating conditions

5.3.1 General operating conditions

Table 9. General operating conditions

Symbol	Parameter	Conditions	Min	Max	Unit
f_{HCLK}	Internal AHB clock frequency		0	72	MHz
f_{PCLK1}	Internal APB1 clock frequency		0	36	
f_{PCLK2}	Internal APB2 clock frequency		0	72	
V_{DD}	Standard operating voltage		2	3.6	V
V_{DDA} ⁽¹⁾	Analog operating voltage (ADC not used)	Must be the same potential as V_{DD} ⁽²⁾	2	3.6	V
	Analog operating voltage (ADC used)		2.4	3.6	
V_{BAT}	Backup operating voltage		1.8	3.6	V



Table 9. General operating conditions (continued)

Symbol	Parameter	Conditions	Min	Max	Unit
P _D	Power dissipation at T _A = 85 °C for suffix 6 or T _A = 105 °C for suffix 7 ⁽³⁾	LFBGA100		454	mW
		LQFP100		434	
		TFBGA64		308	
		LQFP64		444	
		LQFP48		363	
		VFQFPN36		1110	
T _A	Ambient temperature for 6 suffix version	Maximum power dissipation	-40	85	°C
		Low power dissipation ⁽⁴⁾	-40	105	
	Ambient temperature for 7 suffix version	Maximum power dissipation	-40	105	°C
		Low power dissipation ⁽⁴⁾	-40	125	
T _J	Junction temperature range	6 suffix version	-40	105	°C
		7 suffix version	-40	125	

1. When the ADC is used, refer to [Table 45: ADC characteristics](#).
2. It is recommended to power V_{DD} and V_{DDA} from the same source. A maximum difference of 300 mV between V_{DD} and V_{DDA} can be tolerated during power-up and operation.
3. If T_A is lower, higher P_D values are allowed as long as T_J does not exceed T_{Jmax} (see [Table 6.2: Thermal characteristics on page 81](#)).
4. In low power dissipation state, T_A can be extended to this range as long as T_J does not exceed T_{Jmax} (see [Table 6.2: Thermal characteristics on page 81](#)).

5.3.2 Operating conditions at power-up / power-down

Subject to general operating conditions for T_A.

Table 10. Operating conditions at power-up / power-down

Symbol	Parameter	Conditions	Min	Max	Unit
t _{VDD}	V _{DD} rise time rate		0	∞	μs/V
	V _{DD} fall time rate		20	∞	

5.3.3 Embedded reset and power control block characteristics

The parameters given in [Table 11](#) are derived from tests performed under ambient temperature and V_{DD} supply voltage conditions summarized in [Table 9](#).



Table 11. Embedded reset and power control block characteristics

Symbol	Parameter	Conditions	Min	Typ	Max	Unit
V _{PVD}	Programmable voltage detector level selection	PLS[2:0]=000 (rising edge)	2.1	2.18	2.26	V
		PLS[2:0]=000 (falling edge)	2	2.08	2.16	V
		PLS[2:0]=001 (rising edge)	2.19	2.28	2.37	V
		PLS[2:0]=001 (falling edge)	2.09	2.18	2.27	V
		PLS[2:0]=010 (rising edge)	2.28	2.38	2.48	V
		PLS[2:0]=010 (falling edge)	2.18	2.28	2.38	V
		PLS[2:0]=011 (rising edge)	2.38	2.48	2.58	V
		PLS[2:0]=011 (falling edge)	2.28	2.38	2.48	V
		PLS[2:0]=100 (rising edge)	2.47	2.58	2.69	V
		PLS[2:0]=100 (falling edge)	2.37	2.48	2.59	V
		PLS[2:0]=101 (rising edge)	2.57	2.68	2.79	V
		PLS[2:0]=101 (falling edge)	2.47	2.58	2.69	V
		PLS[2:0]=110 (rising edge)	2.66	2.78	2.9	V
		PLS[2:0]=110 (falling edge)	2.56	2.68	2.8	V
		PLS[2:0]=111 (rising edge)	2.76	2.88	3	V
		PLS[2:0]=111 (falling edge)	2.66	2.78	2.9	V
V _{PVDhyst} ⁽²⁾	PVD hysteresis			100		mV
V _{POR/PDR}	Power on/power down reset threshold	Falling edge	1.8 ⁽¹⁾	1.88	1.96	V
		Rising edge	1.84	1.92	2.0	V
V _{PDRhyst} ⁽²⁾	PDR hysteresis			40		mV
T _{RSTTEMPO} ⁽²⁾	Reset temporization		1	2.5	4.5	ms

1. The product behavior is guaranteed by design down to the minimum V_{POR/PDR} value.
2. Guaranteed by design, not tested in production.



5.3.4 Embedded reference voltage

The parameters given in [Table 12](#) are derived from tests performed under ambient temperature and V_{DD} supply voltage conditions summarized in [Table 9](#).

Table 12. Embedded internal reference voltage

Symbol	Parameter	Conditions	Min	Typ	Max	Unit
V_{REFINT}	Internal reference voltage	$-40\text{ }^{\circ}\text{C} < T_A < +105\text{ }^{\circ}\text{C}$	1.16	1.20	1.26	V
		$-40\text{ }^{\circ}\text{C} < T_A < +85\text{ }^{\circ}\text{C}$	1.16	1.20	1.24	V
$T_{S_vrefint}^{(1)}$	ADC sampling time when reading the internal reference voltage			5.1	17.1 ⁽²⁾	μs

1. Shortest sampling time can be determined in the application by multiple iterations.
2. Guaranteed by design, not tested in production.

5.3.5 Supply current characteristics

The current consumption is a function of several parameters and factors such as the operating voltage, ambient temperature, I/O pin loading, device software configuration, operating frequencies, I/O pin switching rate, program location in memory and executed binary code.

The current consumption is measured as described in [Figure 13: Current consumption measurement scheme](#).

All Run-mode current consumption measurements given in this section are performed with a reduced code that gives a consumption equivalent to Dhrystone 2.1 code.

Maximum current consumption

The MCU is placed under the following conditions:

- All I/O pins are in input mode with a static value at V_{DD} or V_{SS} (no load)
- All peripherals are disabled except when explicitly mentioned
- The Flash memory access time is adjusted to the f_{HCLK} frequency (0 wait state from 0 to 24 MHz, 1 wait state from 24 to 48 MHz and 2 wait states above)
- Prefetch in ON (reminder: this bit must be set before clock setting and bus prescaling)
- When the peripherals are enabled $f_{PCLK1} = f_{HCLK}/2$, $f_{PCLK2} = f_{HCLK}$

The parameters given in [Table 13](#), [Table 14](#) and [Table 15](#) are derived from tests performed under ambient temperature and V_{DD} supply voltage conditions summarized in [Table 9](#).



Table 13. Maximum current consumption in Run mode, code with dataprocessing running from Flash

Symbol	Parameter	Conditions	f _{HCLK}	Max ⁽¹⁾		Unit
				T _A = 85 °C	T _A = 105 °C	
I _{DD}	Supply current in Run mode	External clock ⁽²⁾ , all peripherals enabled	72 MHz	50	50.3	mA
			48 MHz	36.1	36.2	
			36 MHz	28.6	28.7	
			24 MHz	19.9	20.1	
			16 MHz	14.7	14.9	
			8 MHz	8.6	8.9	
		External clock ⁽²⁾ , all peripherals disabled	72 MHz	32.8	32.9	
			48 MHz	24.4	24.5	
			36 MHz	19.8	19.9	
			24 MHz	13.9	14.2	
			16 MHz	10.7	11	
			8 MHz	6.8	7.1	

- 1. Based on characterization, not tested in production.
- 2. External clock is 8 MHz and PLL is on when f_{HCLK} > 8 MHz.

Table 14. Maximum current consumption in Run mode, code with dataprocessing running from RAM

Symbol	Parameter	Conditions	f _{HCLK}	Max ⁽¹⁾		Unit
				T _A = 85 °C	T _A = 105 °C	
I _{DD}	Supply current in Run mode	External clock ⁽²⁾ , all peripherals enabled	72 MHz	48	50	mA
			48 MHz	31.5	32	
			36 MHz	24	25.5	
			24 MHz	17.5	18	
			16 MHz	12.5	13	
			8 MHz	7.5	8	
		External clock ⁽²⁾ , all peripherals disabled	72 MHz	29	29.5	
			48 MHz	20.5	21	
			36 MHz	16	16.5	
			24 MHz	11.5	12	
			16 MHz	8.5	9	
			8 MHz	5.5	6	

- 1. Based on characterization, tested in production at V_{DD} max, f_{HCLK} max.
- 2. External clock is 8 MHz and PLL is on when f_{HCLK} > 8 MHz.



Figure 14. Typical current consumption in Run mode versus frequency (at 3.6 V) - code with data processing running from RAM, peripherals enabled

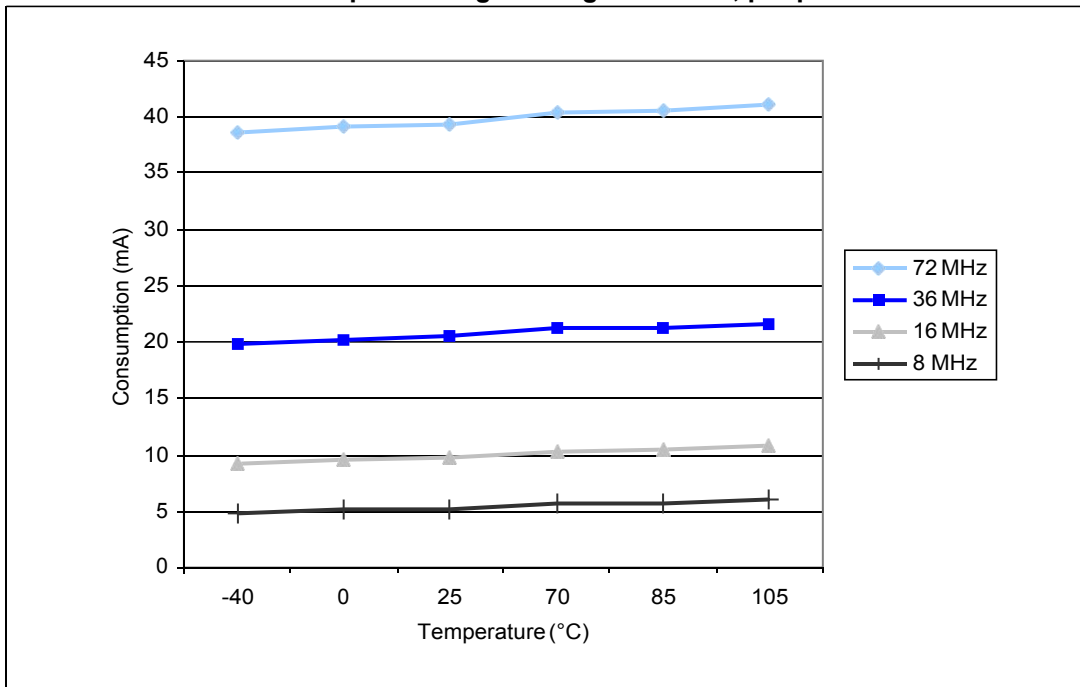

Figure 15. Typical current consumption in Run mode versus frequency (at 3.6 V) - code with data processing running from RAM, peripherals disabled

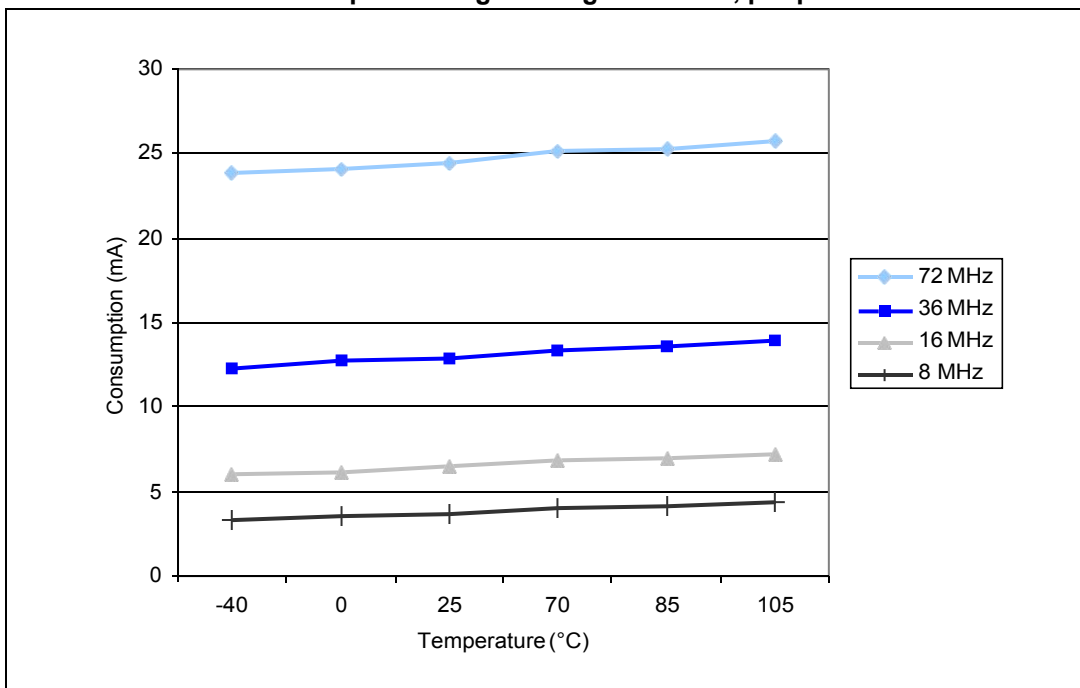



Table 15. Maximum current consumption in Sleep mode, code running from Flash or RAM

Symbol	Parameter	Conditions	f_{HCLK}	Max ⁽¹⁾		Unit
				$T_A = 85\text{ °C}$	$T_A = 105\text{ °C}$	
I_{DD}	Supply current in Sleep mode	External clock ⁽²⁾ , all peripherals enabled	72 MHz	30	32	mA
			48 MHz	20	20.5	
			36 MHz	15.5	16	
			24 MHz	11.5	12	
			16 MHz	8.5	9	
			8 MHz	5.5	6	
		External clock ⁽²⁾ , all peripherals disabled	72 MHz	7.5	8	
			48 MHz	6	6.5	
			36 MHz	5	5.5	
			24 MHz	4.5	5	
			16 MHz	4	4.5	
			8 MHz	3	4	

1. based on characterization, tested in production at $V_{\text{DD max}}$, $f_{\text{HCLK max}}$ with peripherals enabled.
2. External clock is 8 MHz and PLL is on when $f_{\text{HCLK}} > 8\text{ MHz}$.



Table 16. Typical and maximum current consumptions in Stop and Standby modes

Symbol	Parameter	Conditions	Typ ⁽¹⁾		Max		Unit
			V _{DD} /V _{BAT} = 2.4 V	V _{DD} /V _{BAT} = 3.3 V	T _A = 85 °C	T _A = 105 °C	
I _{DD}	Supply current in Stop mode	Regulator in Run mode, low-speed and high-speed internal RC oscillators and high-speed oscillator OFF (no independent watchdog)	23.5	24	200	370	µA
		Regulator in Low Power mode, low-speed and high-speed internal RC oscillators and high-speed oscillator OFF (no independent watchdog)	13.5	14	180	340	
	Supply current in Standby mode	Low-speed internal RC oscillator and independent watchdog ON	2.6	3.4	-	-	
		Low-speed internal RC oscillator ON, independent watchdog OFF	2.4	3.2	-	-	
		Low-speed internal RC oscillator and independent watchdog OFF, low-speed oscillator and RTC OFF	1.7	2	4	5	
I _{DD_VBAT}	Backup domain supply current	Low-speed oscillator and RTC ON	1.1	1.4	1.9 ⁽²⁾	2.2	

1. Typical values are measured at T_A = 25 °C.
2. Based on characterization, not tested in production.

Figure 16. Typical current consumption in Stop mode with regulator in Run mode versus temperature at V_{DD} = 3.3 V and 3.6 V

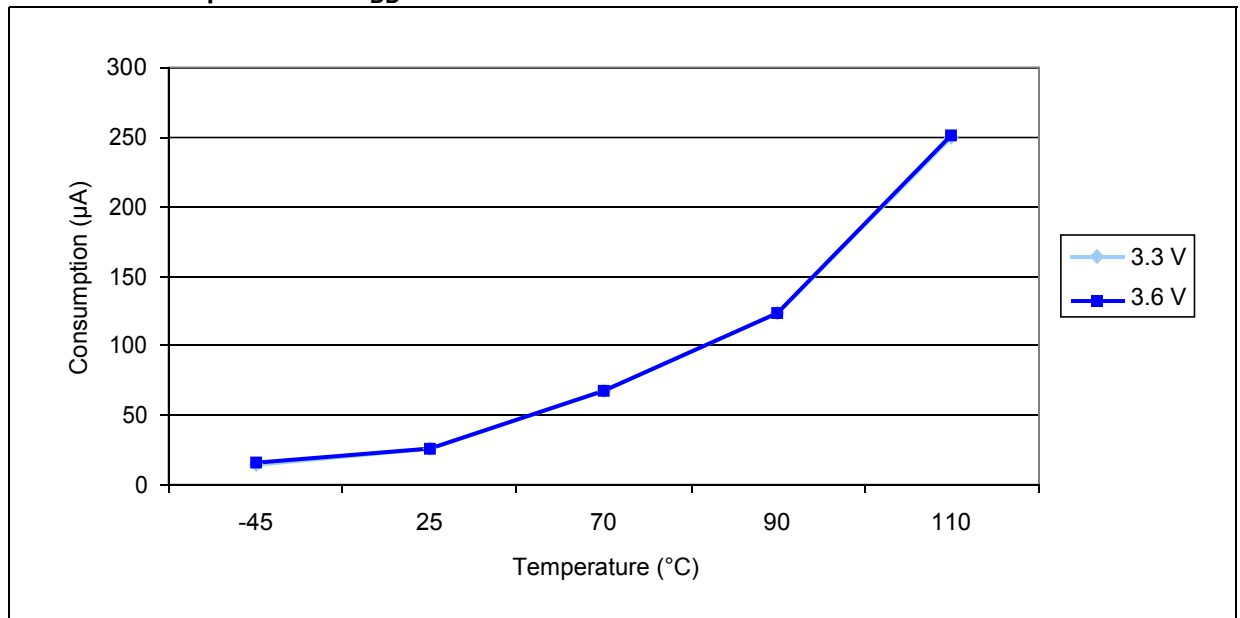



Figure 17. Typical current consumption in Stop mode with regulator in Low-power mode versus temperature at $V_{DD} = 3.3\text{ V}$ and 3.6 V

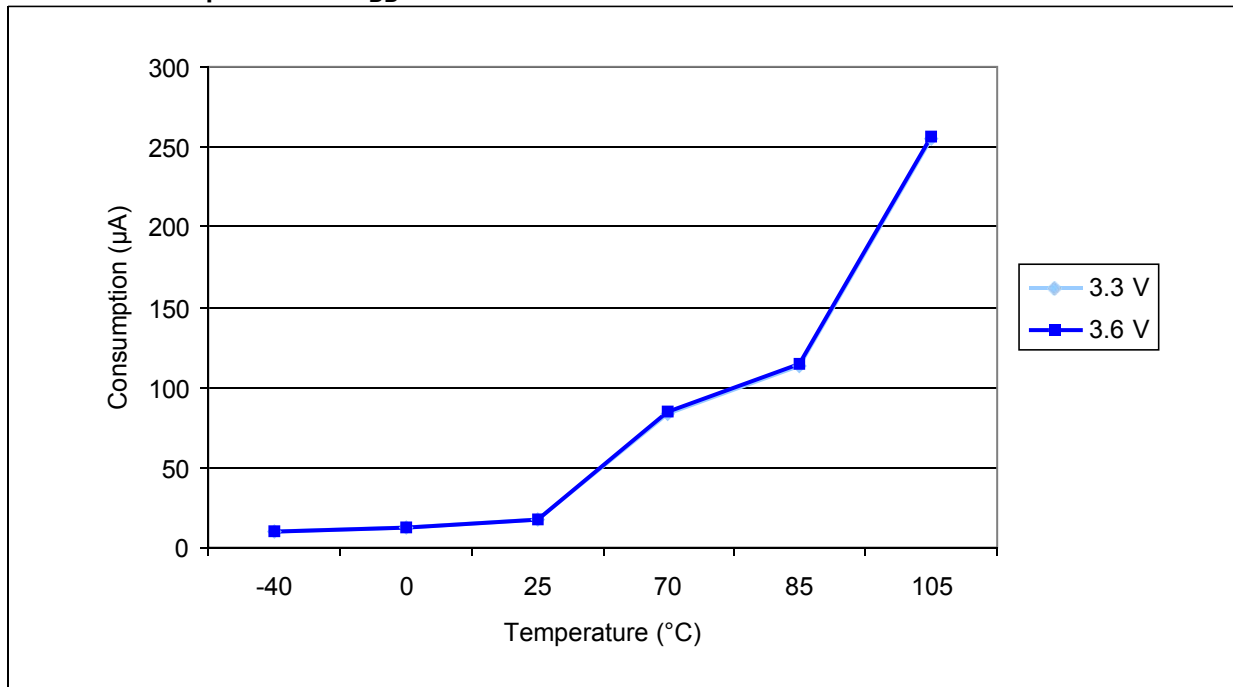
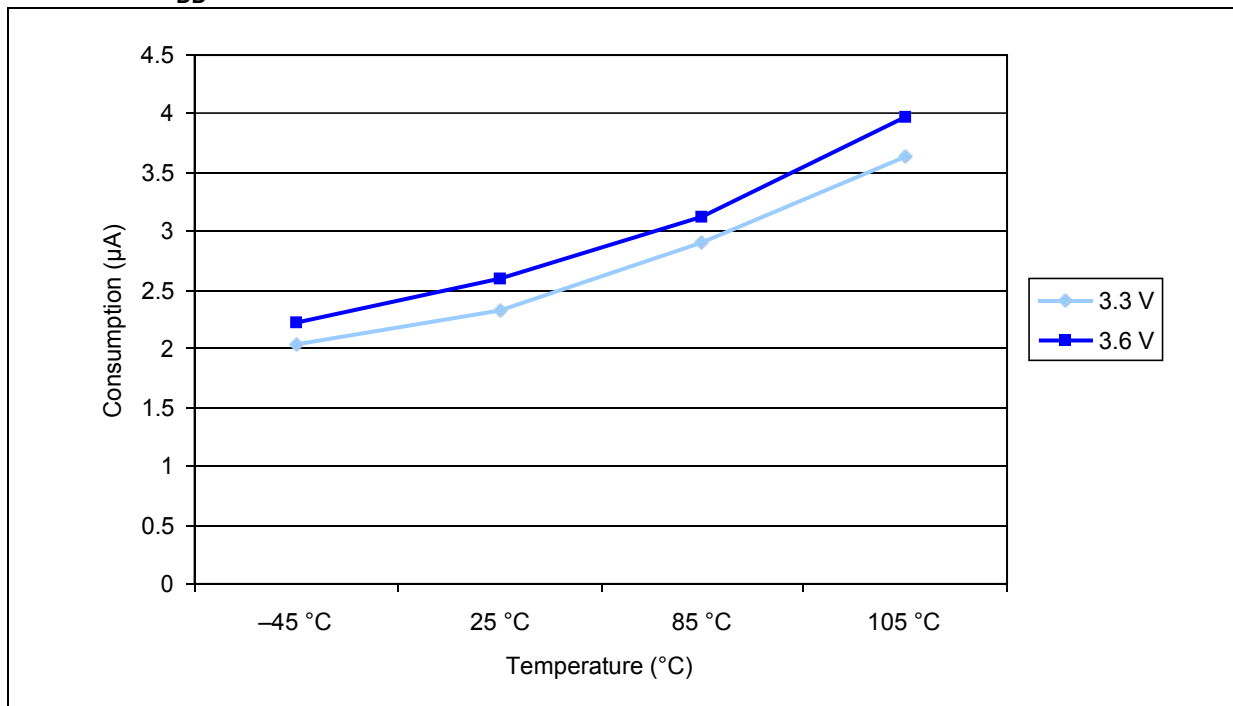

Figure 18. Typical current consumption in Standby mode versus temperature at $V_{DD} = 3.3\text{ V}$ and 3.6 V





Typical current consumption

The MCU is placed under the following conditions:

- All I/O pins are in input mode with a static value at V_{DD} or V_{SS} (no load).
- All peripherals are disabled except if it is explicitly mentioned.
- The Flash access time is adjusted to f_{HCLK} frequency (0 wait state from 0 to 24 MHz, 1 wait state from 24 to 48 MHz and 2 wait states above).
- Ambient temperature and V_{DD} supply voltage conditions summarized in [Table 9](#).
- Prefetch is ON (Reminder: this bit must be set before clock setting and bus prescaling)
- When the peripherals are enabled $f_{PCLK1} = f_{HCLK}/4$, $f_{PCLK2} = f_{HCLK}/2$, $f_{ADCCLK} = f_{PCLK2}/4$

Table 17. Typical current consumption in Run mode, code with data processing running from Flash

Symbol	Parameter	Conditions	f_{HCLK}	Typ ⁽¹⁾		Unit
				All peripherals enabled ⁽²⁾	All peripherals disabled	
I_{DD}	Supply current in Run mode	External clock ⁽³⁾	72 MHz	36	27	mA
			48 MHz	24.2	18.6	
			36 MHz	19	14.8	
			24 MHz	12.9	10.1	
			16 MHz	9.3	7.4	
			8 MHz	5.5	4.6	
			4 MHz	3.3	2.8	
			2 MHz	2.2	1.9	
			1 MHz	1.6	1.45	
			500 kHz	1.3	1.25	
		125 kHz	1.08	1.06		
		Running on high speed internal RC (HSI), AHB prescaler used to reduce the frequency	64 MHz	31.4	23.9	mA
			48 MHz	23.5	17.9	
			36 MHz	18.3	14.1	
			24 MHz	12.2	9.5	
			16 MHz	8.5	6.8	
			8 MHz	4.9	4	
			4 MHz	2.7	2.2	
			2 MHz	1.6	1.4	
			1 MHz	1.02	0.9	
500 kHz	0.73		0.67			
125 kHz	0.5	0.48				

1. Typical values are measures at $T_A = 25\text{ }^\circ\text{C}$, $V_{DD} = 3.3\text{V}$.
2. Add an additional power consumption of 0.8 mA per ADC for the analog part. In applications, this consumption occurs only while the ADC is on (ADON bit is set in the ADC_CR2 register).
3. External clock is 8 MHz and PLL is on when $f_{HCLK} > 8\text{MHz}$.



Table 18. Typical current consumption in Sleep mode, code running from Flash or RAM

Symbol	Parameter	Conditions	f _{HCLK}	Typ ⁽¹⁾		Unit
				All peripherals enabled ⁽²⁾	All peripherals disabled	
I _{DD}	Supply current in Sleep mode	External clock ⁽³⁾	72 MHz	14.4	5.5	mA
			48 MHz	9.9	3.9	
			36 MHz	7.6	3.1	
			24 MHz	5.3	2.3	
			16 MHz	3.8	1.8	
			8 MHz	2.1	1.2	
			4 MHz	1.6	1.1	
			2 MHz	1.3	1	
			1 MHz	1.11	0.98	
			500 kHz	1.04	0.96	
		125 kHz	0.98	0.95		
		Running on high speed internal RC (HSI), AHB prescaler used to reduce the frequency	64 MHz	12.3	4.4	
			48 MHz	9.3	3.3	
			36 MHz	7	2.5	
			24 MHz	4.8	1.8	
			16 MHz	3.2	1.2	
			8 MHz	1.6	0.6	
			4 MHz	1	0.5	
			2 MHz	0.72	0.47	
			1 MHz	0.56	0.44	
500 kHz	0.49		0.42			
125 kHz	0.43	0.41				

1. Typical values are measures at T_A = 25 °C, V_{DD} = 3.3V.
2. Add an additional power consumption of 0.8 mA per ADC for the analog part. In applications, this consumption occurs only while the ADC is on (ADON bit is set in the ADC_CR2 register).
3. External clock is 8 MHz and PLL is on when f_{HCLK} > 8 MHz.



On-chip peripheral current consumption

The current consumption of the on-chip peripherals is given in [Table 19](#). The MCU is placed under the following conditions:

- all I/O pins are in input mode with a static value at V_{DD} or V_{SS} (no load)
- all peripherals are disabled unless otherwise mentioned
- the given value is calculated by measuring the current consumption
 - with all peripherals clocked off
 - with only one peripheral clocked on
- ambient operating temperature and V_{DD} supply voltage conditions summarized in [Table 6](#)

Table 19. Peripheral current consumption⁽¹⁾

Peripheral		Typical consumption at 25 °C	Unit
APB1	TIM2	1.2	mA
	TIM3	1.2	
	TIM4	0.9	
	SPI2	0.2	
	USART2	0.35	
	USART3	0.35	
	I2C1	0.39	
	I2C2	0.39	
	USB	0.65	
	CAN	0.72	
APB2	GPIO A	0.47	mA
	GPIO B	0.47	
	GPIO C	0.47	
	GPIO D	0.47	
	GPIO E	0.47	
	ADC1 ⁽²⁾	1.81	
	ADC2	1.78	
	TIM1	1.6	
	SPI1	0.43	
	USART1	0.85	

1. $f_{HCLK} = 72$ MHz, $f_{APB1} = f_{HCLK}/2$, $f_{APB2} = f_{HCLK}$, default prescaler value for each peripheral.
 2. Specific conditions for ADC: $f_{HCLK} = 56$ MHz, $f_{APB1} = f_{HCLK}/2$, $f_{APB2} = f_{HCLK}$, $f_{ADCCLK} = f_{APB2}/4$, ADON bit in the ADC_CR2 register is set to 1.



5.3.6 External clock source characteristics

High-speed external user clock generated from an external source

The characteristics given in [Table 20](#) result from tests performed using an high-speed external clock source, and under ambient temperature and supply voltage conditions summarized in [Table 9](#).

Table 20. High-speed external user clock characteristics

Symbol	Parameter	Conditions	Min	Typ	Max	Unit
f_{HSE_ext}	User external clock source frequency ⁽¹⁾		0	8	25	MHz
V_{HSEH}	OSC_IN input pin high level voltage		$0.7V_{DD}$		V_{DD}	V
V_{HSEL}	OSC_IN input pin low level voltage		V_{SS}		$0.3V_{DD}$	
$t_{w(HSE)}$ $t_{w(HSE)}$	OSC_IN high or low time ⁽¹⁾		16			ns
$t_{r(HSE)}$ $t_{f(HSE)}$	OSC_IN rise or fall time ⁽¹⁾				20	
$C_{in(HSE)}$	OSC_IN input capacitance ⁽¹⁾			5		pF
$DuCy_{(HSE)}$	Duty cycle		45		55	%
I_L	OSC_IN Input leakage current	$V_{SS} \leq V_{IN} \leq V_D$			± 1	μA

1. Guaranteed by design, not tested in production.

Low-speed external user clock generated from an external source

The characteristics given in [Table 21](#) result from tests performed using an low-speed external clock source, and under ambient temperature and supply voltage conditions summarized in [Table 9](#).

Table 21. Low-speed external user clock characteristics

Symbol	Parameter	Conditions	Min	Typ	Max	Unit
f_{LSE_ext}	User External clock source frequency ⁽¹⁾			32.768	1000	kHz
V_{LSEH}	OSC32_IN input pin high level voltage		$0.7V_{DD}$		V_{DD}	V
V_{LSEL}	OSC32_IN input pin low level voltage		V_{SS}		$0.3V_{DD}$	
$t_{w(LSE)}$ $t_{w(LSE)}$	OSC32_IN high or low time ⁽¹⁾		450			ns
$t_{r(LSE)}$ $t_{f(LSE)}$	OSC32_IN rise or fall time ⁽¹⁾				50	
$C_{in(LSE)}$	OSC32_IN input capacitance ⁽¹⁾			5		pF
$DuCy_{(LSE)}$	Duty cycle		30		70	%

I_L	OSC32_IN Input leakage current	$V_{SS} \leq V_{IN} \leq V_D$			± 1	μA
-------	--------------------------------	-------------------------------	--	--	---------	---------



1. Guaranteed by design, not tested in production.

Figure 19. High-speed external clock source AC timing diagram

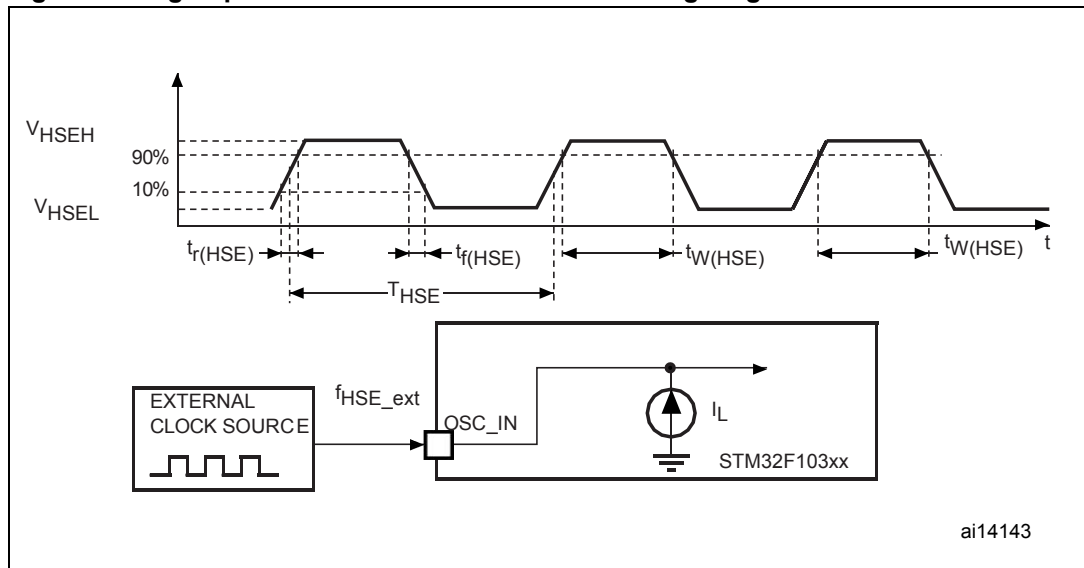

ai14143

Figure 20. Low-speed external clock source AC timing diagram

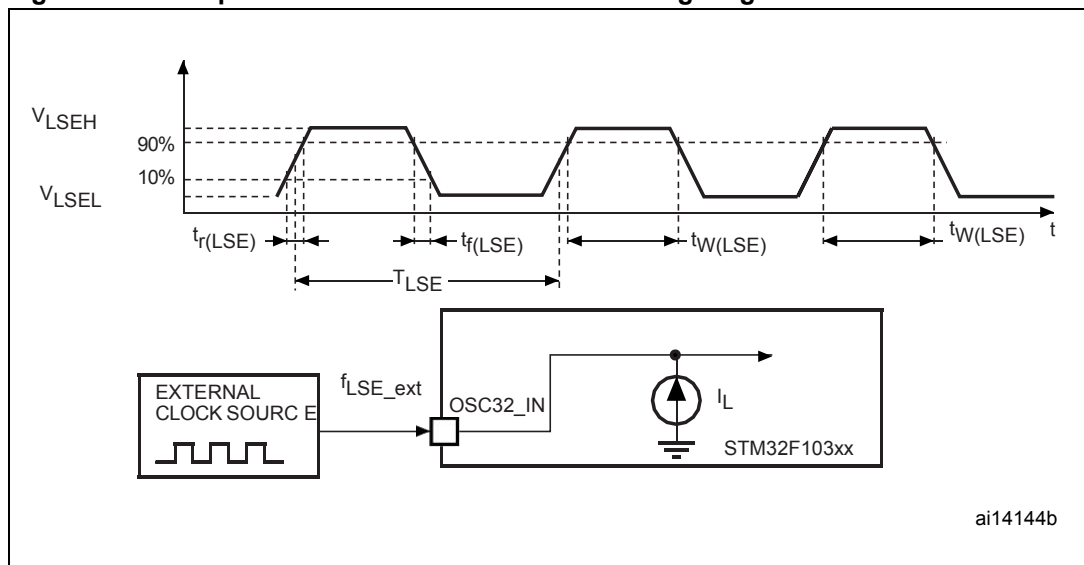

ai14144b

High-speed external clock generated from a crystal/ceramic resonator

The high-speed external (HSE) clock can be supplied with a 4 to 16 MHz crystal/ceramic resonator oscillator. All the information given in this paragraph are based on characterization results obtained with typical external components specified in [Table 22](#). In the application, the resonator and the load capacitors have to be placed as close as possible to the oscillator pins in order to minimize output distortion and startup stabilization time. Refer to the crystal resonator manufacturer for more details on the resonator characteristics (frequency, package, accuracy).

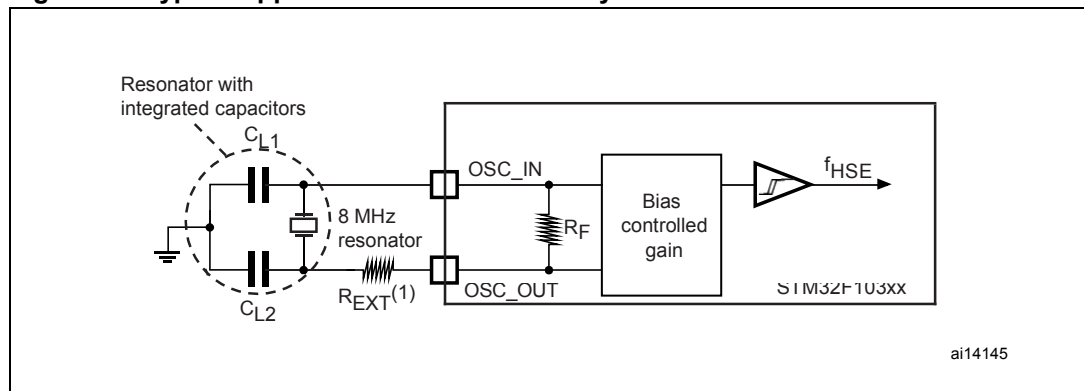

Table 22. HSE 4-16 MHz oscillator characteristics^{(1) (2)}

Symbol	Parameter	Conditions	Min	Typ	Max	Unit
f_{OSC_IN}	Oscillator frequency		4	8	16	MHz
R_F	Feedback resistor			200		k Ω
C_{L1} $C_{L2}^{(3)}$	Recommended load capacitance versus equivalent serial resistance of the crystal (R_S) ⁽⁴⁾	$R_S = 30 \Omega$		30		pF
i_2	HSE driving current	$V_{DD} = 3.3 V, V_{IN} = V_{SS}$ with 30 pF load			1	mA
g_m	Oscillator transconductance	Startup	25			mA/V
$t_{SU(HSE)}^{(5)}$	startup time	V_{DD} is stabilized		2		ms

1. Resonator characteristics given by the crystal/ceramic resonator manufacturer.
2. Based on characterization, not tested in production.
3. For C_{L1} and C_{L2} it is recommended to use high-quality ceramic capacitors in the 5 pF to 25 pF range (typ.), designed for high-frequency applications, and selected to match the requirements of the crystal or resonator. C_{L1} and C_{L2} are usually the same size. The crystal manufacturer typically specifies a load capacitance which is the series combination of C_{L1} and C_{L2} . PCB and MCU pin capacitance must be included (10 pF can be used as a rough estimate of the combined pin and board capacitance) when sizing C_{L1} and C_{L2} .
4. The relatively low value of the RF resistor offers a good protection against issues resulting from use in a humid environment, due to the induced leakage and the bias condition change. However, it is recommended to take this point into account if the MCU is used in tough humidity conditions.
5. $t_{SU(HSE)}$ is the startup time measured from the moment it is enabled (by software) to a stabilized 8 MHz oscillation is reached. This value is measured for a standard crystal resonator and it can vary significantly with the crystal manufacturer

Figure 21. Typical application with an 8 MHz crystal



1. R_{EXT} value depends on the crystal characteristics. Typical value is in the range of 5 to $6R_S$.

Low-speed external clock generated from a crystal/ceramic resonator

The low-speed external (LSE) clock can be supplied with a 32.768 kHz crystal/ceramic resonator oscillator. All the information given in this paragraph are based on characterization results obtained with typical external components specified in [Table 23](#). In the application, the resonator and the load capacitors have to be placed as close as possible to the oscillator pins in order to minimize output distortion and startup stabilization time. Refer to the crystal resonator manufacturer for more details on the resonator characteristics (frequency, package, accuracy).



Note: For C_{L1} and C_{L2} it is recommended to use high-quality ceramic capacitors in the 5 pF to 15 pF range selected to match the requirements of the crystal or resonator. C_{L1} and C_{L2} , are usually the same size. The crystal manufacturer typically specifies a load capacitance which is the series combination of C_{L1} and C_{L2} .

Load capacitance C_L has the following formula: $C_L = C_{L1} \times C_{L2} / (C_{L1} + C_{L2}) + C_{stray}$ where C_{stray} is the pin capacitance and board or trace PCB-related capacitance. Typically, it is between 2 pF and 7 pF.

Caution: To avoid exceeding the maximum value of C_{L1} and C_{L2} (15 pF) it is strongly recommended to use a resonator with a load capacitance $C_L \leq 7$ pF. Never use a resonator with a load capacitance of 12.5 pF.

Example: if you choose a resonator with a load capacitance of $C_L = 6$ pF, and $C_{stray} = 2$ pF, then $C_{L1} = C_{L2} = 8$ pF.

Table 23. LSE oscillator characteristics ($f_{LSE} = 32.768$ kHz) (1)

Symbol	Parameter	Conditions	Min	Typ	Max	Unit
R_F	Feedback resistor			5		M Ω
C_{L1} C_{L2} (2)	Recommended load capacitance versus equivalent serial resistance of the crystal (R_S)(3)	$R_S = 30$ k Ω			15	pF
I_2	LSE driving current	$V_{DD} = 3.3$ V, $V_{IN} = V_{SS}$			1.4	μ A
g_m	Oscillator Transconductance		5			μ A/V
$t_{SU(LSE)}$ (4)	startup time	V_{DD} is stabilized		3		s

1. Based on characterization, not tested in production.
2. Refer to the note and caution paragraphs above the table.
3. The oscillator selection can be optimized in terms of supply current using an high quality resonator with small R_S value for example MSIV-TIN32.768kHz. Refer to crystal manufacturer for more details
4. $t_{SU(LSE)}$ is the startup time measured from the moment it is enabled (by software) to a stabilized 32.768 kHz oscillation is reached. This value is measured for a standard crystal resonator and it can vary significantly with the crystal manufacturer

Figure 22. Typical application with a 32.768 kHz crystal

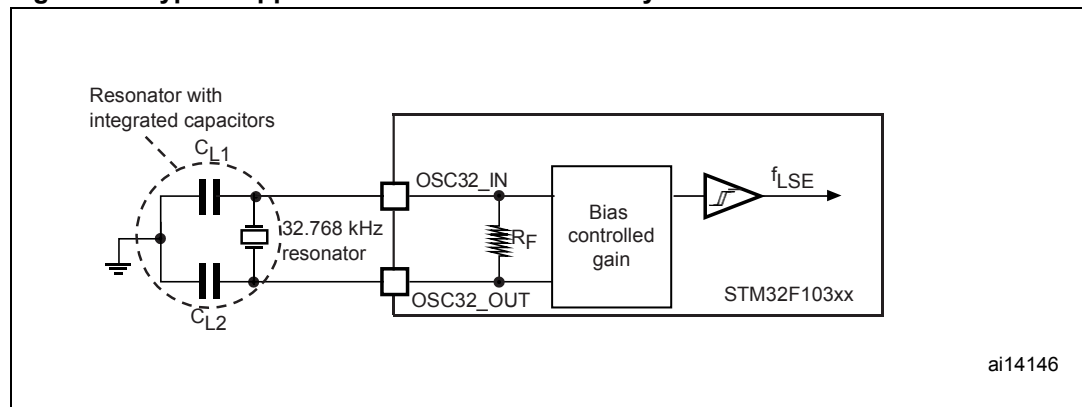

5.3.7 Internal clock source characteristics

The parameters given in [Table 24](#) are derived from tests performed under ambient temperature and V_{DD} supply voltage conditions summarized in [Table 9](#).



High-speed internal (HSI) RC oscillator

Table 24. HSI oscillator characteristics^{(1) (2)}

Symbol	Parameter	Conditions	Min	Typ	Max	Unit
f _{HSI}	Frequency			8		MHz
ACC _{HSI}	Accuracy of HSI oscillator	T _A = -40 to 105 °C	-2	±1	2.5	%
		T _A = -10 to 85 °C	-1.5	±1	2.2	%
		T _A = 0 to 70 °C	-1.3	±1	2	%
		T _A = 25 °C	-1.1	±1	1.8	%
t _{su(HSI)}	HSI oscillator startup time		1		2	µs
I _{DD(HSI)}	HSI oscillator power consumption			80	100	µA

1. Guaranteed by design, not tested in production.
2. V_{DD} = 3.3 V, T_A = -40 to 105 °C unless otherwise specified.

Low-speed internal (LSI) RC oscillator

Table 25. LSI oscillator characteristics⁽¹⁾

Symbol	Parameter	Min	Typ	Max	Unit
f _{LSI} ⁽²⁾	Frequency	30	40	60	kHz
t _{su(LSI)} ⁽³⁾	LSI oscillator startup time			85	µs
I _{DD(LSI)} ⁽³⁾	LSI oscillator power consumption		0.65	1.2	µA

1. V_{DD} = 3 V, T_A = -40 to 105 °C unless otherwise specified.
2. Based on characterization, not tested in production.
3. Guaranteed by design, not tested in production.

Wakeup time from low-power mode

The wakeup times given in [Table 26](#) is measured on a wakeup phase with a 8-MHz HSI RC oscillator. The clock source used to wake up the device depends from the current operating mode:

- Stop or Standby mode: the clock source is the RC oscillator
- Sleep mode: the clock source is the clock that was set before entering Sleep mode.

All timings are derived from tests performed under ambient temperature and V_{DD} supply voltage conditions summarized in [Table 9](#).



Table 26. Low-power mode wakeup timings

Symbol	Parameter	Conditions	Typ	Unit
$t_{WUSLEEP}^{(1)}$	Wakeup from Sleep mode	Wakeup on HSI RC clock	1.8	μs
$t_{WUSTOP}^{(1)}$	Wakeup from Stop mode (regulator in run mode)	HSI RC wakeup time = 2 μs	3.6	μs
	Wakeup from Stop mode (regulator in low power mode)	HSI RC wakeup time = 2 μs , Regulator wakeup from LP mode time = 5 μs	5.4	
$t_{WUSTDBY}^{(1)}$	Wakeup from Standby mode	HSI RC wakeup time = 2 μs , Regulator wakeup from power down time = 38 μs	50	μs

1. The wakeup times are measured from the wakeup event to the point in which the user application code reads the first instruction.

5.3.8 PLL characteristics

The parameters given in [Table 27](#) are derived from tests performed under ambient temperature and V_{DD} supply voltage conditions summarized in [Table 9](#).

Table 27. PLL characteristics

Symbol	Parameter	Test conditions	Value			Unit
			Min ⁽¹⁾	Typ	Max ⁽¹⁾	
f_{PLL_IN}	PLL input clock ⁽²⁾		1	8.0	25	MHz
	PLL input clock duty cycle		40		60	%
f_{PLL_OUT}	PLL multiplier output clock		16		72	MHz
t_{LOCK}	PLL lock time				200	μs

1. Based on characterization, not tested in production.

2. Take care of using the appropriate multiplier factors so as to have PLL input clock values compatible with the range defined by f_{PLL_OUT} .

5.3.9 Memory characteristics

Flash memory

The characteristics are given at $T_A = -40$ to 105 °C unless otherwise specified.

Table 28. Flash memory characteristics

Symbol	Parameter	Conditions	Min ⁽¹⁾	Typ	Max ⁽¹⁾	Unit
t_{prog}	16-bit programming time	$T_A = -40$ to $+105$ °C	40	52.5	70	μs
t_{ERASE}	Page (1 KB) erase time	$T_A = -40$ to $+105$ °C	20		40	ms
t_{ME}	Mass erase time	$T_A = -40$ to $+105$ °C	20		40	ms



Table 28. Flash memory characteristics (continued)

Symbol	Parameter	Conditions	Min ⁽¹⁾	Typ	Max ⁽¹⁾	Unit
I _{DD}	Supply current	Read mode f _{HCLK} = 72 MHz with 2 wait states, V _{DD} = 3.3 V			20	mA
		Write / Erase modes f _{HCLK} = 72 MHz, V _{DD} = 3.3 V			5	mA
		Power-down mode / Halt, V _{DD} = 3.0 to 3.6 V			50	µA
V _{prog}	Programming voltage		2		3.6	V

1. Guaranteed by design, not tested in production.

Table 29. Flash memory endurance and data retention

Symbol	Parameter	Conditions	Value			Unit
			Min ⁽¹⁾	Typ	Max	
N _{END}	Endurance	T _A = -40 to +85 °C (6 suffix versions) T _A = -40 to +105 °C (7 suffix versions)	10			kcycles
t _{RET}	Data retention	1 kcycle ⁽²⁾ at T _A = 85 °C	30			Years
		1 kcycle ⁽²⁾ at T _A = 105 °C	10			
		10 kcycles ⁽²⁾ at T _A = 55 °C	20			

1. Based on characterization, not tested in production.

2. Cycling performed over the whole temperature range.

5.3.10 EMC characteristics

Susceptibility tests are performed on a sample basis during device characterization.

Functional EMS (electromagnetic susceptibility)

While a simple application is executed on the device (toggling 2 LEDs through I/O ports), the device is stressed by two electromagnetic events until a failure occurs. The failure is indicated by the LEDs:

- **Electrostatic discharge (ESD)** (positive and negative) is applied to all device pins until a functional disturbance occurs. This test is compliant with the IEC 1000-4-2 standard.
- **FTB:** A Burst of Fast Transient voltage (positive and negative) is applied to V_{DD} and V_{SS} through a 100 pF capacitor, until a functional disturbance occurs. This test is compliant with the IEC 1000-4-4 standard.

A device reset allows normal operations to be resumed.

The test results are given in [Table 30](#). They are based on the EMS levels and classes defined in application note AN1709.



Table 30. EMS characteristics

Symbol	Parameter	Conditions	Level/Class
V_{FESD}	Voltage limits to be applied on any I/O pin to induce a functional disturbance	$V_{DD} = 3.3\text{ V}$, $T_A = +25\text{ }^\circ\text{C}$, $f_{HCLK} = 72\text{ MHz}$ conforms to IEC 1000-4-2	2B
V_{EFTB}	Fast transient voltage burst limits to be applied through 100 pF on V_{DD} and V_{SS} pins to induce a functional disturbance	$V_{DD} = 3.3\text{ V}$, $T_A = +25\text{ }^\circ\text{C}$, $f_{HCLK} = 72\text{ MHz}$ conforms to IEC 1000-4-4	4A

Designing hardened software to avoid noise problems

EMC characterization and optimization are performed at component level with a typical application environment and simplified MCU software. It should be noted that good EMC performance is highly dependent on the user application and the software in particular.

Therefore it is recommended that the user applies EMC software optimization and prequalification tests in relation with the EMC level requested for his application.

Software recommendations

The software flowchart must include the management of runaway conditions such as:

- Corrupted program counter
- Unexpected reset
- Critical Data corruption (control registers...)

Prequalification trials

Most of the common failures (unexpected reset and program counter corruption) can be reproduced by manually forcing a low state on the NRST pin or the Oscillator pins for 1 second.

To complete these trials, ESD stress can be applied directly on the device, over the range of specification values. When unexpected behavior is detected, the software can be hardened to prevent unrecoverable errors occurring (see application note AN1015).

Electromagnetic Interference (EMI)

The electromagnetic field emitted by the device are monitored while a simple application is executed (toggling 2 LEDs through the I/O ports). This emission test is compliant with SAE J 1752/3 standard which specifies the test board and the pin loading.

Table 31. EMI characteristics

Symbol	Parameter	Conditions	Monitored frequency band	Max vs. [f_{HSE}/f_{HCLK}]		Unit
				8/48 MHz	8/72 MHz	
S_{EMI}	Peak level	$V_{DD} = 3.3\text{ V}$, $T_A = 25\text{ }^\circ\text{C}$, LQFP100 package compliant with SAE J 1752/3	0.1 to 30 MHz	12	12	dB μ V
			30 to 130 MHz	22	19	
			130 MHz to 1GHz	23	29	
			SAE EMI Level	4	4	-



5.3.11 Absolute maximum ratings (electrical sensitivity)

Based on three different tests (ESD, LU) using specific measurement methods, the device is stressed in order to determine its performance in terms of electrical sensitivity.

Electrostatic discharge (ESD)

Electrostatic discharges (a positive then a negative pulse separated by 1 second) are applied to the pins of each sample according to each pin combination. The sample size depends on the number of supply pins in the device (3 parts × (n+1) supply pins). This test conforms to the JESD22-A114/C101 standard.

Table 32. ESD absolute maximum ratings

Symbol	Ratings	Conditions	Class	Maximum value ⁽¹⁾	Unit
V _{ESD(HBM)}	Electrostatic discharge voltage (human body model)	T _A = +25 °C conforming to JESD22-A114	2	2000	V
V _{ESD(CDM)}	Electrostatic discharge voltage (charge device model)	T _A = +25 °C conforming to JESD22-C101	II	500	

1. Based on characterization results, not tested in production.

Static latch-up

Two complementary static tests are required on six parts to assess the latch-up performance:

- A supply overvoltage is applied to each power supply pin
- A current injection is applied to each input, output and configurable I/O pin

These tests are compliant with EIA/JESD 78A IC latch-up standard.

Table 33. Electrical sensitivities

Symbol	Parameter	Conditions	Class
LU	Static latch-up class	T _A = +105 °C conforming to JESD78A	II level A



5.3.12 I/O port characteristics

General input/output characteristics

Unless otherwise specified, the parameters given in [Table 34](#) are derived from tests performed under the conditions summarized in [Table 9](#). All I/Os are CMOS and TTL compliant.

Table 34. I/O static characteristics

Symbol	Parameter	Conditions	Min	Typ	Max	Unit
V_{IL}	Input low level voltage	TTL ports	-0.5		0.8	V
V_{IH}	Standard IO input high level voltage		2		$V_{DD}+0.5$	
	IO FT ⁽¹⁾ input high level voltage		2		5.5V	
V_{IL}	Input low level voltage	CMOS ports	-0.5		$0.35 V_{DD}$	V
V_{IH}	Input high level voltage		$0.65 V_{DD}$		$V_{DD}+0.5$	
V_{hys}	Standard IO Schmitt trigger voltage hysteresis ⁽²⁾		200			mV
	IO FT Schmitt trigger voltage hysteresis ⁽²⁾		$5\% V_{DD}$ ⁽³⁾			mV
I_{lkg}	Input leakage current ⁽⁴⁾	$V_{SS} \leq V_{IN} \leq V_{DD}$ Standard I/Os			± 1	μA
		$V_{IN} = 5 V$ I/O FT			3	
R_{PU}	Weak pull-up equivalent resistor ⁽⁵⁾	$V_{IN} = V_{SS}$	30	40	50	$k\Omega$
R_{PD}	Weak pull-down equivalent resistor ⁽⁵⁾	$V_{IN} = V_{DD}$	30	40	50	$k\Omega$
C_{IO}	I/O pin capacitance			5		pF

1. FT = Five-volt tolerant.
2. Hysteresis voltage between Schmitt trigger switching levels. Based on characterization, not tested in production.
3. With a minimum of 100 mV.
4. Leakage could be higher than max. if negative current is injected on adjacent pins.
5. Pull-up and pull-down resistors are designed with a true resistance in series with a switchable PMOS/NMOS. This MOS/NMOS contribution to the series resistance is minimum (~10% order).

All I/Os are CMOS and TTL compliant (no software configuration required), their characteristics consider the most strict CMOS-technology or TTL parameters:

- For V_{IH} :
 - if V_{DD} is in the [2.00 V - 3.08 V] range: CMOS characteristics but TTL included
 - if V_{DD} is in the [3.08 V - 3.60 V] range: TTL characteristics but CMOS included
- For V_{IL} :
 - if V_{DD} is in the [2.00 V - 2.28 V] range: TTL characteristics but CMOS included
 - if V_{DD} is in the [2.28 V - 3.60 V] range: CMOS characteristics but TTL included



Output driving current

The GPIOs (general purpose input/outputs) can sink or source up to +/-8 mA, and sink +20 mA (with a relaxed V_{OL}).

In the user application, the number of I/O pins which can drive current must be limited to respect the absolute maximum rating specified in [Section 5.2](#):

- The sum of the currents sourced by all the I/Os on V_{DD} , plus the maximum Run consumption of the MCU sourced on V_{DD} , cannot exceed the absolute maximum rating I_{VDD} (see [Table 7](#)).
- The sum of the currents sunk by all the I/Os on V_{SS} plus the maximum Run consumption of the MCU sunk on V_{SS} cannot exceed the absolute maximum rating I_{VSS} (see [Table 7](#)).

Output voltage levels

Unless otherwise specified, the parameters given in [Table 35](#) are derived from tests performed under ambient temperature and V_{DD} supply voltage conditions summarized in [Table 9](#). All I/Os are CMOS and TTL compliant.

Table 35. Output voltage characteristics

Symbol	Parameter	Conditions	Min	Max	Unit
$V_{OL}^{(1)}$	Output low level voltage for an I/O pin when 8 pins are sunk at same time	TTL port $I_{IO} = +8 \text{ mA}$ $2.7 \text{ V} < V_{DD} < 3.6 \text{ V}$		0.4	V
$V_{OH}^{(2)}$	Output high level voltage for an I/O pin when 8 pins are sourced at same time		$V_{DD}-0.4$		
$V_{OL}^{(1)}$	Output low level voltage for an I/O pin when 8 pins are sunk at same time	CMOS port $I_{IO} = +8 \text{ mA}$ $2.7 \text{ V} < V_{DD} < 3.6 \text{ V}$		0.4	V
$V_{OH}^{(2)}$	Output high level voltage for an I/O pin when 8 pins are sourced at same time		2.4		
$V_{OL}^{(1)(3)}$	Output low level voltage for an I/O pin when 8 pins are sunk at same time	$I_{IO} = +20 \text{ mA}$ $2.7 \text{ V} < V_{DD} < 3.6 \text{ V}$		1.3	V
$V_{OH}^{(2)(3)}$	Output high level voltage for an I/O pin when 8 pins are sourced at same time		$V_{DD}-1.3$		
$V_{OL}^{(1)(3)}$	Output low level voltage for an I/O pin when 8 pins are sunk at same time	$I_{IO} = +6 \text{ mA}$ $2 \text{ V} < V_{DD} < 2.7 \text{ V}$		0.4	V
$V_{OH}^{(2)(3)}$	Output high level voltage for an I/O pin when 8 pins are sourced at same time		$V_{DD}-0.4$		

1. The I_{IO} current sunk by the device must always respect the absolute maximum rating specified in [Table 7](#) and the sum of I_{IO} (I/O ports and control pins) must not exceed I_{VSS} .
2. The I_{IO} current sourced by the device must always respect the absolute maximum rating specified in [Table 7](#) and the sum of I_{IO} (I/O ports and control pins) must not exceed I_{VDD} .
3. Based on characterization data, not tested in production.



Input/output AC characteristics

The definition and values of input/output AC characteristics are given in [Figure 23](#) and [Table 36](#), respectively.

Unless otherwise specified, the parameters given in [Table 36](#) are derived from tests performed under the ambient temperature and V_{DD} supply voltage conditions summarized in [Table 9](#).

Table 36. I/O AC characteristics⁽¹⁾

MODEx[1:0] bit value ⁽¹⁾	Symbol	Parameter	Conditions	Min	Max	Unit
10	f _{max(IO)out}	Maximum frequency ⁽²⁾	C _L = 50 pF, V _{DD} = 2 V to 3.6 V		2	MHz
	t _{f(IO)out}	Output high to low level fall time	C _L = 50 pF, V _{DD} = 2 V to 3.6 V		125 ⁽³⁾	ns
	t _{r(IO)out}	Output low to high level rise time			125 ⁽³⁾	
01	f _{max(IO)out}	Maximum frequency ⁽²⁾	C _L = 50 pF, V _{DD} = 2 V to 3.6 V		10	MHz
	t _{f(IO)out}	Output high to low level fall time	C _L = 50 pF, V _{DD} = 2 V to 3.6 V		25 ⁽³⁾	ns
	t _{r(IO)out}	Output low to high level rise time			25 ⁽³⁾	
11	F _{max(IO)out}	Maximum frequency ⁽²⁾	C _L = 30 pF, V _{DD} = 2.7 V to 3.6 V		50	MHz
			C _L = 50 pF, V _{DD} = 2.7 V to 3.6 V		30	MHz
			C _L = 50 pF, V _{DD} = 2 V to 2.7 V		20	MHz
	t _{f(IO)out}	Output high to low level fall time	C _L = 30 pF, V _{DD} = 2.7 V to 3.6 V		5 ⁽³⁾	ns
			C _L = 50 pF, V _{DD} = 2.7 V to 3.6 V		8 ⁽³⁾	
			C _L = 50 pF, V _{DD} = 2 V to 2.7 V		12 ⁽³⁾	
	t _{r(IO)out}	Output low to high level rise time	C _L = 30 pF, V _{DD} = 2.7 V to 3.6 V		5 ⁽³⁾	
			C _L = 50 pF, V _{DD} = 2.7 V to 3.6 V		8 ⁽³⁾	
			C _L = 50 pF, V _{DD} = 2 V to 2.7 V		12 ⁽³⁾	
-	t _{EXTIpw}	Pulse width of external signals detected by the EXTI controller		10		ns

1. The I/O speed is configured using the MODEx[1:0] bits. Refer to the STM32F10xxx reference manual for a description of GPIO Port configuration register.
2. The maximum frequency is defined in [Figure 23](#).
3. Guaranteed by design, not tested in production.



Figure 23. I/O AC characteristics definition

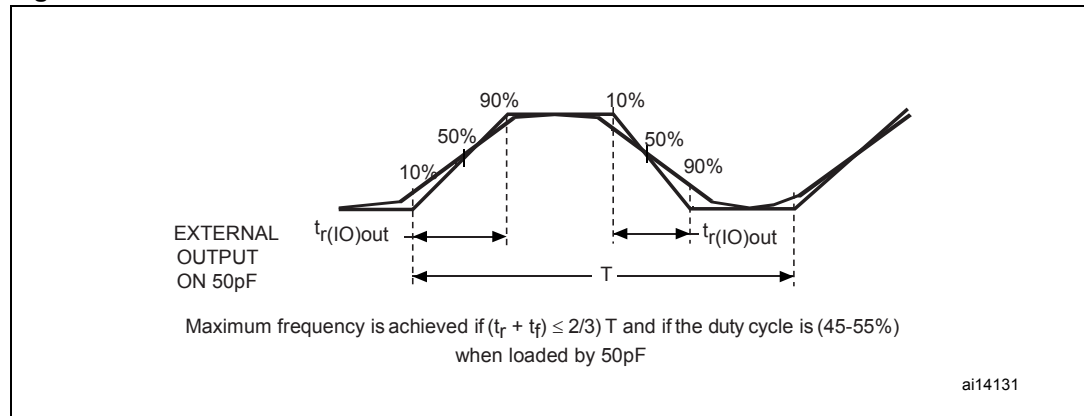

5.3.13 NRST pin characteristics

The NRST pin input driver uses CMOS technology. It is connected to a permanent pull-up resistor, R_{PU} (see [Table 34](#)).

Unless otherwise specified, the parameters given in [Table 37](#) are derived from tests performed under the ambient temperature and V_{DD} supply voltage conditions summarized in [Table 9](#).

Table 37. NRST pin characteristics

Symbol	Parameter	Conditions	Min	Typ	Max	Unit
$V_{IL(NRST)}^{(1)}$	NRST Input low level voltage		-0.5		0.8	V
$V_{IH(NRST)}^{(1)}$	NRST Input high level voltage		2		$V_{DD}+0.5$	
$V_{hys(NRST)}$	NRST Schmitt trigger voltage hysteresis			200		mV
R_{PU}	Weak pull-up equivalent resistor ⁽²⁾	$V_{IN} = V_{SS}$	30	40	50	k Ω
$V_{F(NRST)}^{(1)}$	NRST Input filtered pulse				100	ns
$V_{NF(NRST)}^{(1)}$	NRST Input not filtered pulse		300			ns

1. Guaranteed by design, not tested in production.
2. The pull-up is designed with a true resistance in series with a switchable PMOS. This PMOS contribution to the series resistance must be minimum (~10% order).



Figure 24. Recommended NRST pin protection

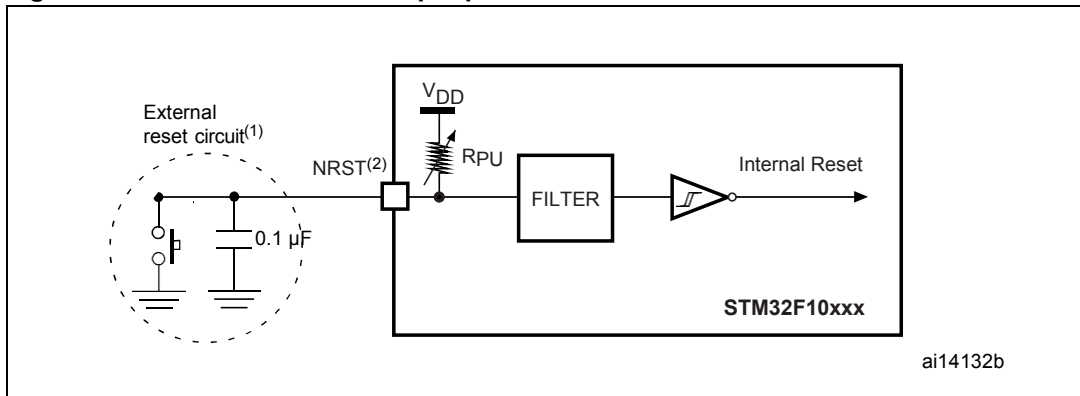

2. The reset network protects the device against parasitic resets.
3. The user must ensure that the level on the NRST pin can go below the $V_{IL(NRST)}$ max level specified in [Table 37](#). Otherwise the reset will not be taken into account by the device.

5.3.14 TIM timer characteristics

The parameters given in [Table 38](#) are guaranteed by design.

Refer to [Section 5.3.12: I/O port characteristics](#) for details on the input/output alternate function characteristics (output compare, input capture, external clock, PWM output).

Table 38. TIMx⁽¹⁾ characteristics

Symbol	Parameter	Conditions	Min	Max	Unit
$t_{res(TIM)}$	Timer resolution time		1		$t_{TIMxCLK}$
		$f_{TIMxCLK} = 72 \text{ MHz}$	13.9		ns
f_{EXT}	Timer external clock frequency on CH1 to CH4		0	$f_{TIMxCLK}/2$	MHz
		$f_{TIMxCLK} = 72 \text{ MHz}$	0	36	MHz
Res_{TIM}	Timer resolution			16	bit
$t_{COUNTER}$	16-bit counter clock period when internal clock is selected		1	65536	$t_{TIMxCLK}$
		$f_{TIMxCLK} = 72 \text{ MHz}$	0.0139	910	μs
t_{MAX_COUNT}	Maximum possible count			65536×65536	$t_{TIMxCLK}$
		$f_{TIMxCLK} = 72 \text{ MHz}$		59.6	s

1. TIMx is used as a general term to refer to the TIM1, TIM2, TIM3 and TIM4 timers.



5.3.15 Communications interfaces

I²C interface characteristics

Unless otherwise specified, the parameters given in [Table 39](#) are derived from tests performed under the ambient temperature, f_{PCLK1} frequency and V_{DD} supply voltage conditions summarized in [Table 9](#).

The STM32F103xx performance line I²C interface meets the requirements of the standard I²C communication protocol with the following restrictions: the I/O pins SDA and SCL are mapped to are not “true” open-drain. When configured as open-drain, the PMOS connected between the I/O pin and V_{DD} is disabled, but is still present.

The I²C characteristics are described in [Table 39](#). Refer also to [Section 5.3.12: I/O port characteristics](#) for more details on the input/output alternate function characteristics (SDA and SCL).

Table 39. I²C characteristics

Symbol	Parameter	Standard mode I ² C ⁽¹⁾		Fast mode I ² C ⁽¹⁾⁽²⁾		Unit
		Min	Max	Min	Max	
$t_{w(SCLL)}$	SCL clock low time	4.7		1.3		μs
$t_{w(SCLH)}$	SCL clock high time	4.0		0.6		
$t_{su(SDA)}$	SDA setup time	250		100		ns
$t_{h(SDA)}$	SDA data hold time	0 ⁽³⁾		0 ⁽⁴⁾	900 ⁽³⁾	
$t_{r(SDA)}$ $t_{r(SCL)}$	SDA and SCL rise time		1000	$20 + 0.1C_b$	300	
$t_{f(SDA)}$ $t_{f(SCL)}$	SDA and SCL fall time		300		300	
$t_{h(STA)}$	Start condition hold time	4.0		0.6		μs
$t_{su(STA)}$	Repeated Start condition setup time	4.7		0.6		
$t_{su(STO)}$	Stop condition setup time	4.0		0.6		μs
$t_{w(STO:STA)}$	Stop to Start condition time (bus free)	4.7		1.3		μs
C_b	Capacitive load for each bus line		400		400	pF

1. Guaranteed by design, not tested in production.
2. f_{PCLK1} must be higher than 2 MHz to achieve the maximum standard mode I²C frequency. It must be higher than 4 MHz to achieve the maximum fast mode I²C frequency.
3. The maximum hold time of the Start condition has only to be met if the interface does not stretch the low period of SCL signal.
4. The device must internally provide a hold time of at least 300ns for the SDA signal in order to bridge the undefined region of the falling edge of SCL.



Figure 25. I²C bus AC waveforms and measurement circuit

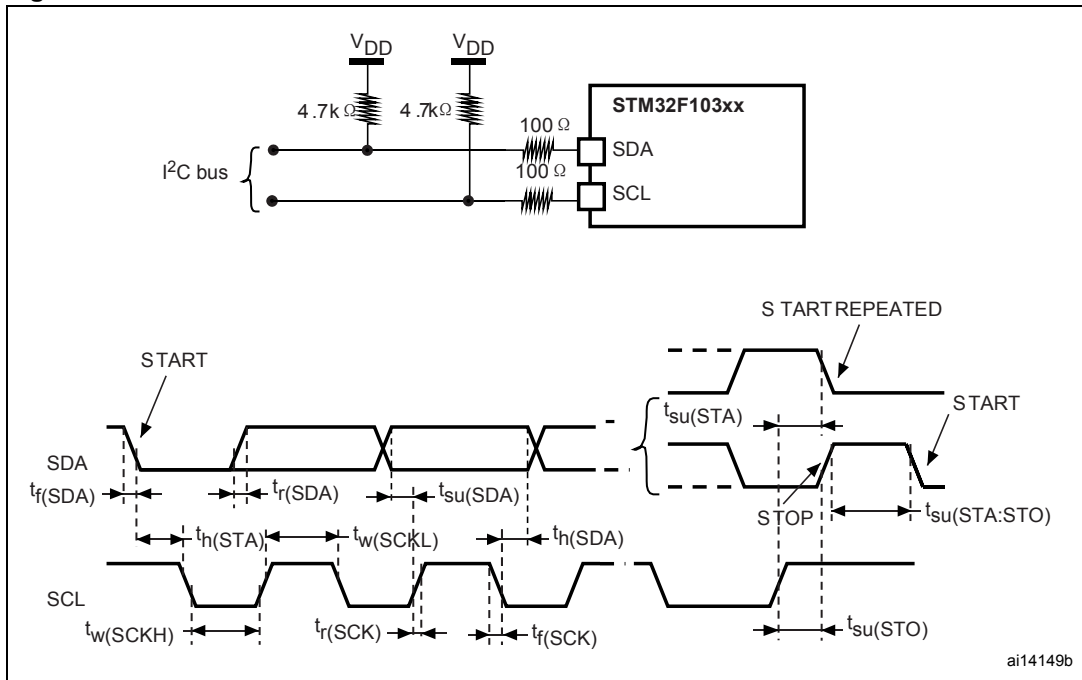

1. Measurement points are done at CMOS levels: 0.3V_{DD} and 0.7V_{DD}.

Table 40. SCL frequency (f_{PCLK1} = 36 MHz., V_{DD} = 3.3 V)⁽¹⁾⁽²⁾

f _{SCL} (kHz)	I2C_CCR value
	R _P = 4.7 kΩ
400	0x801E
300	0x8028
200	0x803C
100	0x00B4
50	0x0168
20	0x0384

1. R_P = External pull-up resistance, f_{SCL} = I²C speed,
2. For speeds around 200 kHz, the tolerance on the achieved speed is of ±5%. For other speed ranges, the tolerance on the achieved speed ±2%. These variations depend on the accuracy of the external components used to design the application.



SPI interface characteristics

Unless otherwise specified, the parameters given in [Table 41](#) are derived from tests performed under the ambient temperature, f_{PCLKx} frequency and V_{DD} supply voltage conditions summarized in [Table 9](#).

Refer to [Section 5.3.12: I/O port characteristics](#) for more details on the input/output alternate function characteristics (NSS, SCK, MOSI, MISO).

Table 41. SPI characteristics⁽¹⁾

Symbol	Parameter	Conditions	Min	Max	Unit
f_{SCK} $1/t_{c(SCK)}$	SPI clock frequency	Master mode	0	18	MHz
		Slave mode	0	18	
$t_{r(SCK)}$ $t_{f(SCK)}$	SPI clock rise and fall time	Capacitive load: C = 30 pF		8	ns
$t_{su(NSS)}^{(2)}$	NSS setup time	Slave mode	$4 t_{PCLK}$		
$t_{h(NSS)}^{(2)}$	NSS hold time	Slave mode	73		
$t_{w(SCKH)}^{(2)}$ $t_{w(SCKL)}^{(2)}$	SCK high and low time	Master mode, $f_{PCLK} = 36$ MHz, presc = 4	50	60	
$t_{su(MI)}^{(2)}$	Data input setup time Master mode	SPI1	1		
		SPI2	5		
$t_{su(SI)}^{(2)}$	Data input setup time Slave mode		1		
$t_{h(MI)}^{(2)}$	Data input hold time Master mode	SPI1	1		
		SPI2	5		
$t_{h(SI)}^{(2)}$	Data input hold time Slave mode		3		
$t_{a(SO)}^{(2)(3)}$	Data output access time	Slave mode, $f_{PCLK} = 36$ MHz, presc = 4	0	55	
		Slave mode, $f_{PCLK} = 24$ MHz	0	$4 t_{PCLK}$	
$t_{dis(SO)}^{(2)(4)}$	Data output disable time	Slave mode	10		
$t_{v(SO)}^{(2)(1)}$	Data output valid time	Slave mode (after enable edge)		25	
$t_{v(MO)}^{(2)(1)}$	Data output valid time	Master mode (after enable edge)		3	
$t_{h(SO)}^{(2)}$ $t_{h(MO)}^{(2)}$	Data output hold time	Slave mode (after enable edge)	25		
		Master mode (after enable edge)	4		

1. Remapped SPI1 characteristics to be determined.
2. Based on characterization, not tested in production.
3. Min time is for the minimum time to drive the output and the max time is for the maximum time to validate the data.
4. Min time is for the minimum time to invalidate the output and the max time is for the maximum time to put the data in Hi-Z



Figure 26. SPI timing diagram - slave mode and CPHA = 0

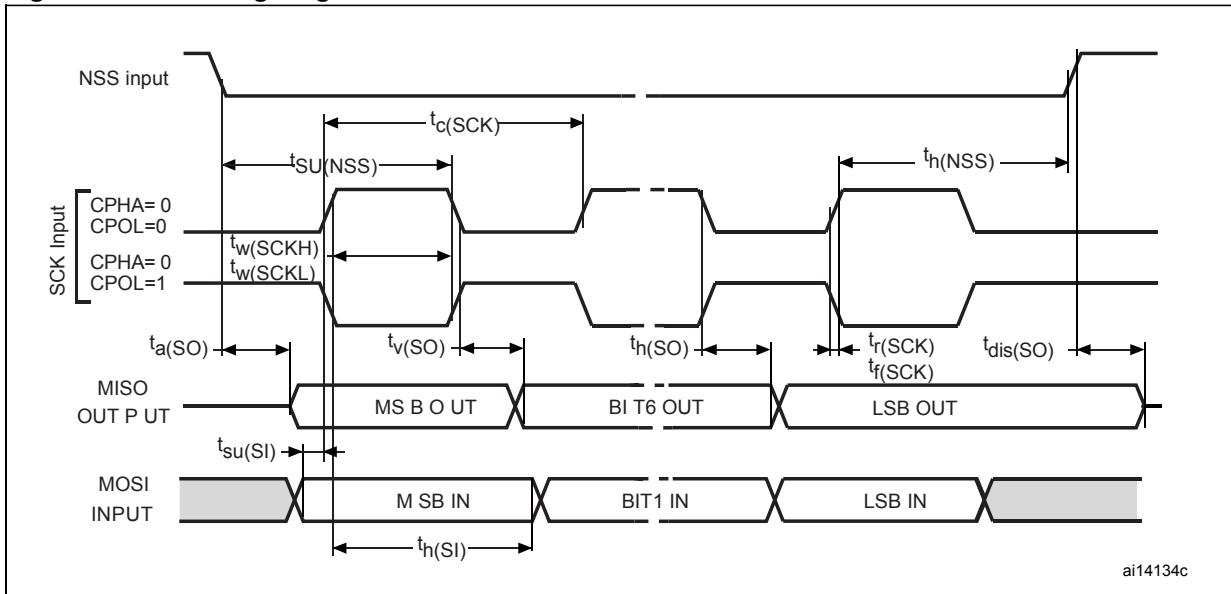
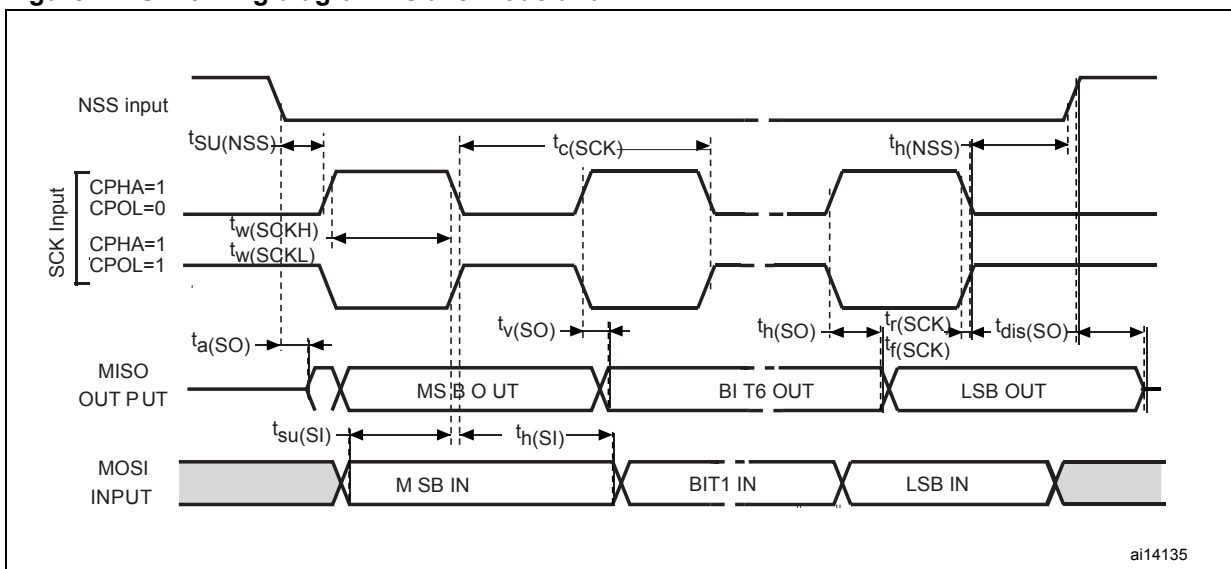

Figure 27. SPI timing diagram - slave mode and CPHA = 1⁽¹⁾



1. Measurement points are done at CMOS levels: 0.3V_{DD} and 0.7V_{DD}.



Figure 28. SPI timing diagram - master mode⁽¹⁾

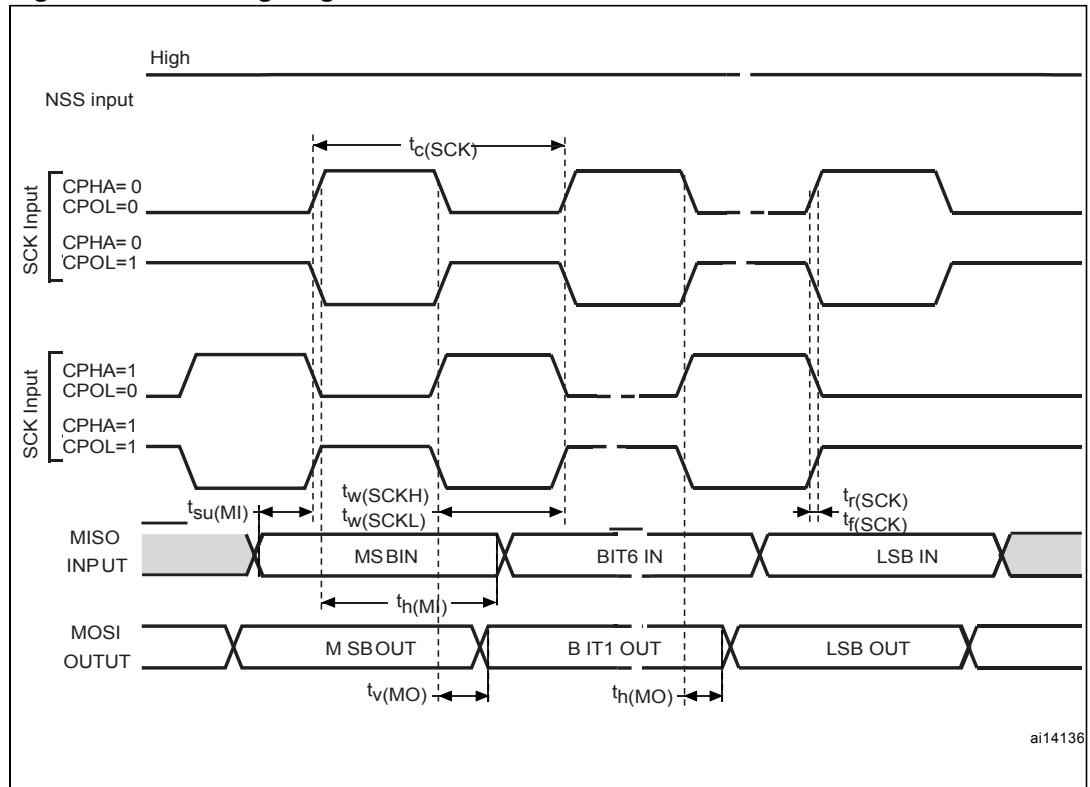

1. Measurement points are done at CMOS levels: $0.3V_{DD}$ and $0.7V_{DD}$.

USB characteristics

The USB interface is USB-IF certified (Full Speed).

Table 42. USB startup time

Symbol	Parameter	Max	Unit
$t_{STARTUP}^{(1)}$	USB transceiver startup time	1	μs

1. Guaranteed by design, not tested in production.



Table 43. USB DC electrical characteristics

Symbol	Parameter	Conditions	Min. ⁽¹⁾	Max. ⁽¹⁾	Unit
Input levels					
V _{DD}	USB operating voltage ⁽²⁾		3.0 ⁽³⁾	3.6	V
V _{DI} ⁽⁴⁾	Differential input sensitivity	I(USBDP, USBDM)	0.2		V
V _{CM} ⁽⁴⁾	Differential common mode range	Includes V _{DI} range	0.8	2.5	
V _{SE} ⁽⁴⁾	Single ended receiver threshold		1.3	2.0	
Output levels					
V _{OL}	Static output level low	R _L of 1.5 kΩ to 3.6 V ⁽⁵⁾		0.3	V
V _{OH}	Static output level high	R _L of 15 kΩ to V _{SS} ⁽⁵⁾	2.8	3.6	

1. All the voltages are measured from the local ground potential.
2. To be compliant with the USB 2.0 full-speed electrical specification, the USBDP (D+) pin should be pulled up with a 1.5 kΩ resistor to a 3.0-to-3.6 V voltage range.
3. The STM32F103xx USB functionality is ensured down to 2.7 V but not the full USB electrical characteristics which are degraded in the 2.7-to-3.0 V V_{DD} voltage range.
4. Guaranteed by design, not tested in production.
5. R_L is the load connected on the USB drivers

Figure 29. USB timings: definition of data signal rise and fall time

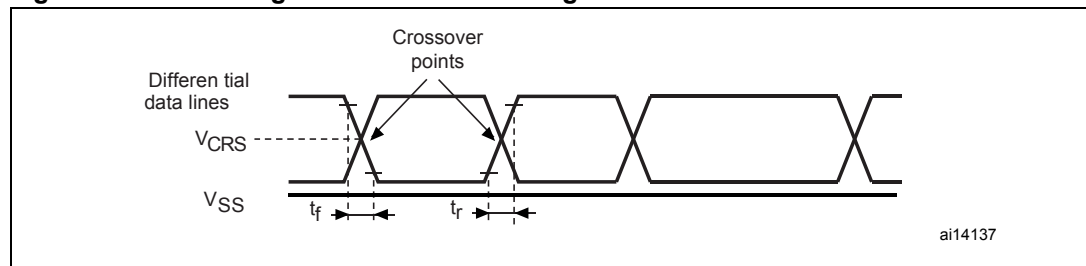

Table 44. USB: Full-speed electrical characteristics⁽¹⁾

Symbol	Parameter	Conditions	Min	Max	Unit
Driver characteristics					
t _r	Rise time ⁽²⁾	C _L = 50 pF	4	20	ns
t _f	Fall time ⁽²⁾	C _L = 50 pF	4	20	ns
t _{rfm}	Rise/ fall time matching	t _r /t _f	90	110	%
V _{CRS}	Output signal crossover voltage		1.3	2.0	V

1. Guaranteed by design, not tested in production.
2. Measured from 10% to 90% of the data signal. For more detailed informations, please refer to USB Specification - Chapter 7 (version 2.0).

5.3.16 CAN (controller area network) interface

Refer to [Section 5.3.12: I/O port characteristics](#) for more details on the input/output alternate function characteristics (CAN_TX and CAN_RX).



5.3.17 12-bit ADC characteristics

Unless otherwise specified, the parameters given in [Table 45](#) are derived from tests performed under the ambient temperature, f_{PCLK2} frequency and V_{DDA} supply voltage conditions summarized in [Table 9](#).

Note: It is recommended to perform a calibration after each power-up.

Table 45. ADC characteristics

Symbol	Parameter	Conditions	Min	Typ	Max	Unit
V_{DDA}	Power supply		2.4		3.6	V
V_{REF+}	Positive reference voltage		2.4		V_{DDA}	V
I_{VREF}	Current on the V_{REF} input pin			160 ⁽¹⁾	220 ⁽¹⁾	μA
f_{ADC}	ADC clock frequency		0.6		14	MHz
$f_S^{(2)}$	Sampling rate		0.05		1	MHz
$f_{TRIG}^{(2)}$	External trigger frequency	$f_{ADC} = 14$ MHz			823	kHz
					17	$1/f_{ADC}$
$V_{AIN}^{(3)}$	Conversion voltage range		0 (V_{SSA} or V_{REF-} tied to ground)		V_{REF+}	V
$R_{AIN}^{(2)}$	External input impedance		See Equation 1 and Table 46			$k\Omega$
$R_{ADC}^{(2)}$	Sampling switch resistance				1	$k\Omega$
$C_{(2)ADC}$	Internal sample and hold capacitor				12	pF
$t_{CAL}^{(2)}$	Calibration time	$f_{ADC} = 14$ MHz	5.9			μs
			83			$1/f_{ADC}$
$t_{lat}^{(2)}$	Injection trigger conversion latency	$f_{ADC} = 14$ MHz			0.214	μs
					3 ⁽⁴⁾	$1/f_{ADC}$
$t_{lat_r}^{(2)}$	Regular trigger conversion latency	$f_{ADC} = 14$ MHz			0.143	μs
					2 ⁽⁴⁾	$1/f_{ADC}$
$t_S^{(2)}$	Sampling time	$f_{ADC} = 14$ MHz	0.107		17.1	μs
			1.5		239.5	$1/f_{ADC}$
$t_{STAB}^{(2)}$	Power-up time		0	0	1	μs
$t_{CONV}^{(2)}$	Total conversion time (including sampling time)	$f_{ADC} = 14$ MHz	1		18	μs
			14 to 252 (t_S for sampling +12.5 for successive approximation)			$1/f_{ADC}$

1. Based on characterization, not tested in production.
2. Guaranteed by design, not tested in production.
3. In devices delivered in VFQFPN and LQFP packages, V_{REF+} is internally connected to V_{DDA} and V_{REF-} is internally connected to V_{SSA} . Devices that come in the TFBGA64 package have a V_{REF+} pin but no V_{REF-} pin (V_{REF-} is internally connected to V_{SSA}), see [Table 5](#) and [Figure 6](#).
4. For external triggers, a delay of $1/f_{PCLK2}$ must be added to the latency specified in [Table 45](#).



Equation 1: R_{AIN} max formula:

$$R_{AIN} < \frac{T_S}{f_{ADC} \times C_{ADC} \times \ln(2^N + 2)} R_{ADC}$$

The formula above ([Equation 1](#)) is used to determine the maximum external impedance allowed for an error below 1/4 of LSB. Here N = 12 (from 12-bit resolution).

Table 46. R_{AIN} max for f_{ADC} = 14 MHz⁽¹⁾

T _s (cycles)	t _s (μs)	R _{AIN} max (kΩ)
1.5	0.11	1.2
7.5	0.54	10
13.5	0.96	19
28.5	2.04	41
41.5	2.96	60
55.5	3.96	80
71.5	5.11	104
239.5	17.1	350

1. Based on characterization, not tested in production.

Table 47. ADC accuracy - limited test conditions^{(1) (2)}

Symbol	Parameter	Test conditions	Typ	Max ⁽³⁾	Unit
ET	Total unadjusted error	f _{PCLK2} = 56 MHz, f _{ADC} = 14 MHz, R _{AIN} < 10 kΩ, V _{DDA} = 3 V to 3.6 V T _A = 25 °C Measurements made after ADC calibration	±1.3	±2	LSB
EO	Offset error		±1	±1.5	
EG	Gain error		±0.5	±1.5	
ED	Differential linearity error		±0.7	±1	
EL	Integral linearity error		±0.8	±1.5	

- ADC DC accuracy values are measured after internal calibration.
- ADC Accuracy vs. Negative Injection Current: Injecting negative current on any of the standard (non-robust) analog input pins should be avoided as this significantly reduces the accuracy of the conversion being performed on another analog input. It is recommended to add a Schottky diode (pin to ground) to standard analog pins which may potentially inject negative current. Any positive injection current within the limits specified for I_{INJ(PIN)} and ΣI_{INJ(PIN)} in [Section 5.3.12](#) does not affect the ADC accuracy.
- Based on characterization, not tested in production.



Table 48. ADC accuracy^{(1) (2) (3)}

Symbol	Parameter	Test conditions	Typ	Max ⁽⁴⁾	Unit
ET	Total unadjusted error	$f_{PCLK2} = 56 \text{ MHz}$, $f_{ADC} = 14 \text{ MHz}$, $R_{AIN} < 10 \text{ k}\Omega$, $V_{DDA} = 2.4 \text{ V to } 3.6 \text{ V}$ Measurements made after ADC calibration	± 2	± 5	LSB
EO	Offset error		± 1.5	± 2.5	
EG	Gain error		± 1.5	± 3	
ED	Differential linearity error		± 1	± 2	
EL	Integral linearity error		± 1.5	± 3	

1. ADC DC accuracy values are measured after internal calibration.
2. Better performance could be achieved in restricted V_{DD} , frequency and temperature ranges.
3. ADC Accuracy vs. Negative Injection Current: Injecting negative current on any of the standard (non-robust) analog input pins should be avoided as this significantly reduces the accuracy of the conversion being performed on another analog input. It is recommended to add a Schottky diode (pin to ground) to standard analog pins which may potentially inject negative current. Any positive injection current within the limits specified for $I_{INJ(PIN)}$ and $\Sigma I_{INJ(PIN)}$ in [Section 5.3.12](#) does not affect the ADC accuracy.
4. Based on characterization, not tested in production.

Figure 30. ADC accuracy characteristics

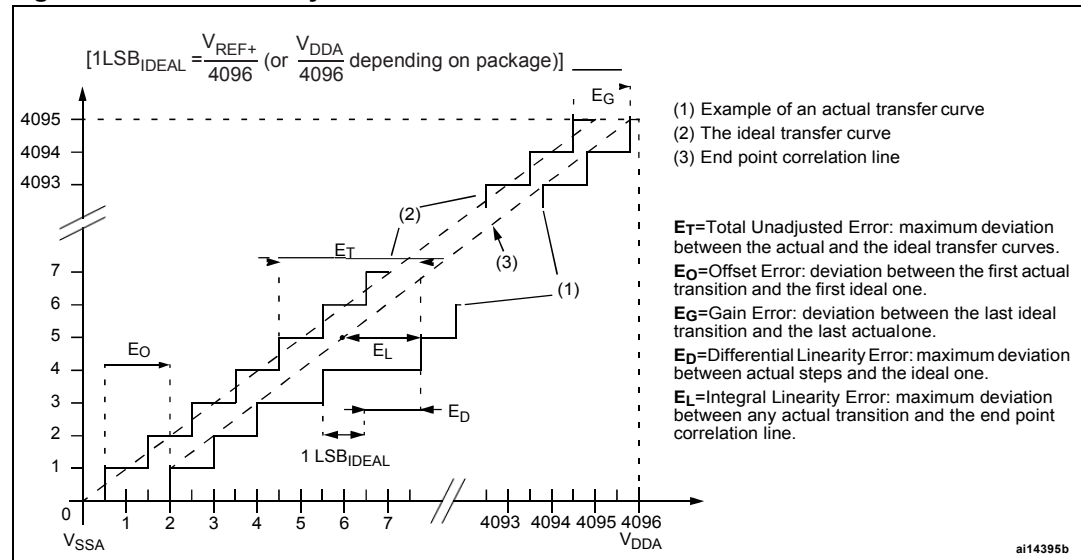
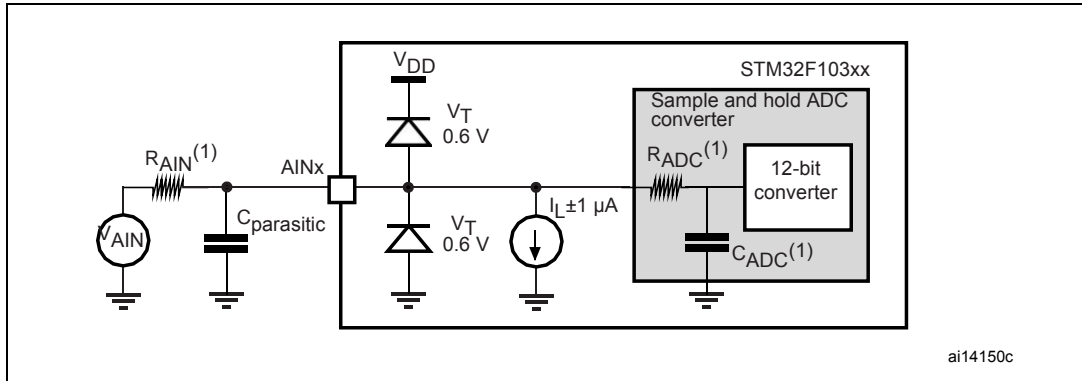



Figure 31. Typical connection diagram using the ADC



1. Refer to [Table 45](#) for the values of R_{AIN} , R_{ADC} and C_{ADC} .
2. $C_{parasitic}$ represents the capacitance of the PCB (dependent on soldering and PCB layout quality) plus the pad capacitance (roughly 7 pF). A high $C_{parasitic}$ value will downgrade conversion accuracy. To remedy this, f_{ADC} should be reduced.

General PCB design guidelines

Power supply decoupling should be performed as shown in [Figure 32](#) or [Figure 33](#), depending on whether V_{REF+} is connected to V_{DDA} or not. The 10 nF capacitors should be ceramic (good quality). They should be placed them as close as possible to the chip.

Figure 32. Power supply and reference decoupling (V_{REF+} not connected to V_{DDA})

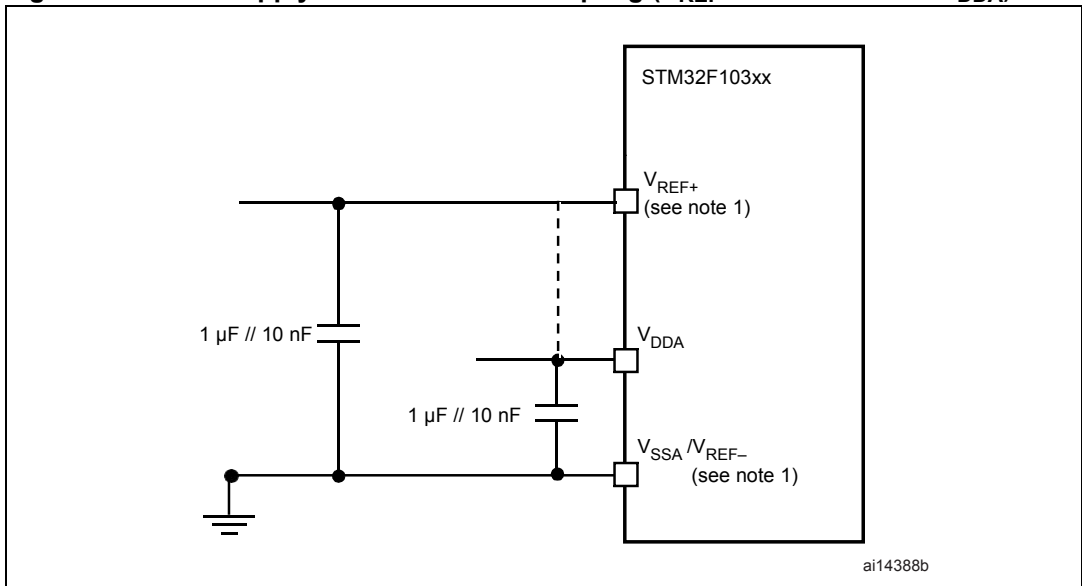

1. V_{REF+} and V_{REF-} inputs are available only on 100-pin packages.



Figure 33. Power supply and reference decoupling (V_{REF+} connected to V_{DDA})

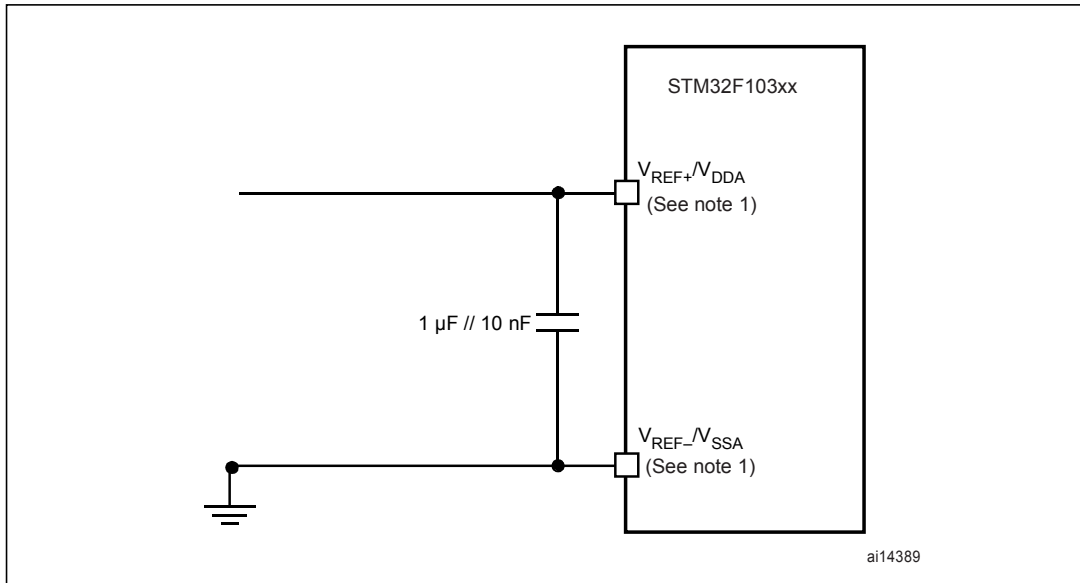

1. V_{REF+} and V_{REF-} inputs are available only on 100-pin packages.

5.3.18 Temperature sensor characteristics

Table 49. TS characteristics

Symbol	Parameter	Min	Typ	Max	Unit
$T_L^{(1)}$	V_{SENSE} linearity with temperature		± 1	± 2	$^{\circ}C$
Avg_Slope ⁽¹⁾	Average slope	4.0	4.3	4.6	mV/ $^{\circ}C$
$V_{25}^{(1)}$	Voltage at 25 $^{\circ}C$	1.34	1.43	1.52	V
$t_{START}^{(2)}$	Startup time	4		10	μs
$T_{S_temp}^{(3)(2)}$	ADC sampling time when reading the temperature			17.1	μs

1. Based on characterization, not tested in production.
2. Guaranteed by design, not tested in production.
3. Shortest sampling time can be determined in the application by multiple iterations.



6 Package characteristics

6.1 Package mechanical data

In order to meet environmental requirements, ST offers these devices in different grades of ECOPACK[®] packages, depending on their level of environmental compliance. ECOPACK[®] specifications, grade definitions and product status are available at: www.st.com. ECOPACK[®] is an ST trademark.



Figure 34. VFQFPN36 6 x 6 mm, 0.5 mm pitch, package outline⁽¹⁾

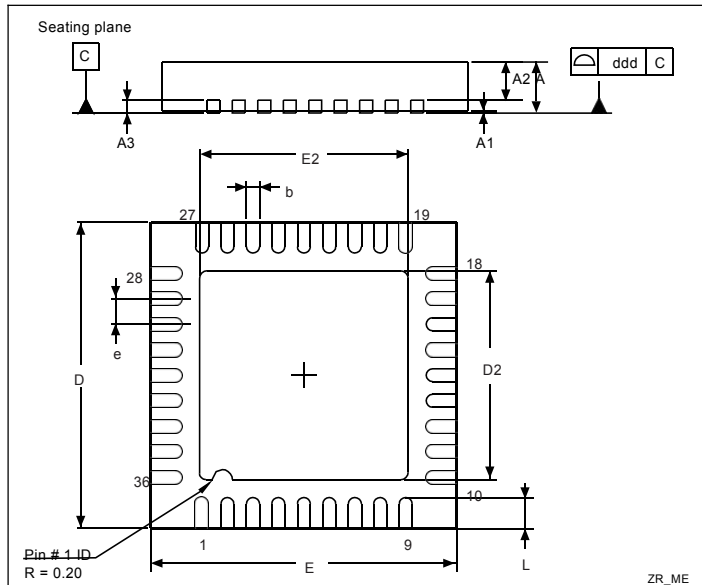
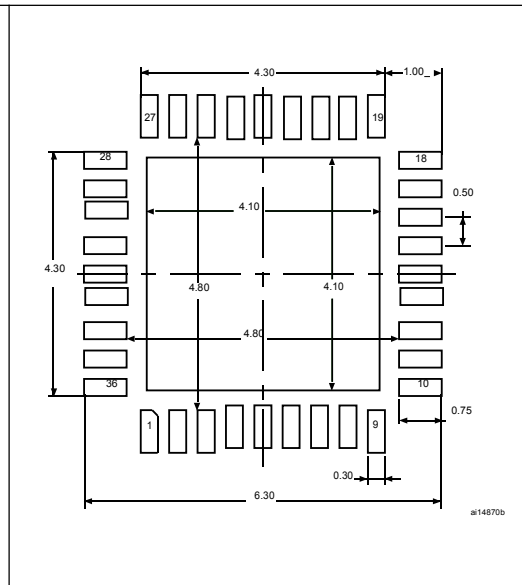

Figure 35. Recommended footprint (dimensions in mm)⁽¹⁾⁽²⁾⁽³⁾



1. Drawing is not to scale.
2. The back-side pad is not internally connected to the V_{SS} or V_{DD} power pads.
3. There is an exposed die pad on the underside of the VFQFPN package. It should be soldered to the PCB. All leads should also be soldered to the PCB.

Table 50. VFQFPN36 6 x 6 mm, 0.5 mm pitch, package mechanical data

Symbol	millimeters			inches ⁽¹⁾		
	Min	Typ	Max	Min	Typ	Max
A	0.800	0.900	1.000	0.0315	0.0354	0.0394
A1		0.020	0.050		0.0008	0.0020
A2		0.650	1.000		0.0256	0.0394
A3		0.250			0.0098	
b	0.180	0.230	0.300	0.0071	0.0091	0.0118
D	5.875	6.000	6.125	0.2313	0.2362	0.2411
D2	1.750	3.700	4.250	0.0689	0.1457	0.1673
E	5.875	6.000	6.125	0.2313	0.2362	0.2411
E2	1.750	3.700	4.250	0.0689	0.1457	0.1673
e	0.450	0.500	0.550	0.0177	0.0197	0.0217
L	0.350	0.550	0.750	0.0138	0.0217	0.0295
ddd		0.080			0.0031	

1. Values in inches are converted from mm and rounded to 4 decimal digits.



Figure 36. LFBGA100 - low profile fine pitch ball grid array package outline

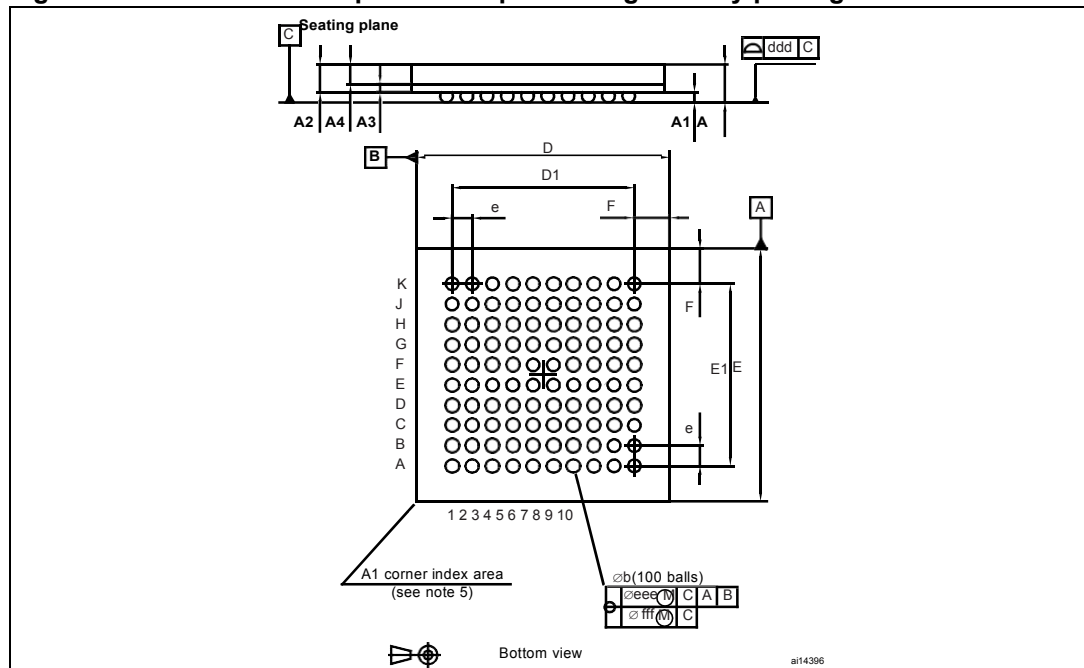

1. Drawing is not to scale.

Table 51. LFBGA100 - low profile fine pitch ball grid array package mechanical data

Dim.	mm			inches ⁽¹⁾		
	Min	Typ	Max	Min	Typ	Max
A			1.700			0.0669
A1	0.270			0.0106		
A2		1.085			0.0427	
A3		0.30			0.0118	
A4			0.80			0.0315
b	0.45	0.50	0.55	0.0177	0.0197	0.0217
D	9.85	10.00	10.15	0.3878	0.3937	0.3996
D1		7.20			0.2835	
E	9.85	10.00	10.15	0.3878	0.3937	0.3996
E1		7.20			0.2835	
e		0.80			0.0315	
F		1.40			0.0551	
ddd			0.12			0.0047
eee			0.15			0.0059
fff			0.08			0.0031
N (number of balls)	100					

1. Values in inches are converted from mm and rounded to 4 decimal digits.



Figure 37. Recommended PCB design rules (0.80/0.75 mm pitch BGA)

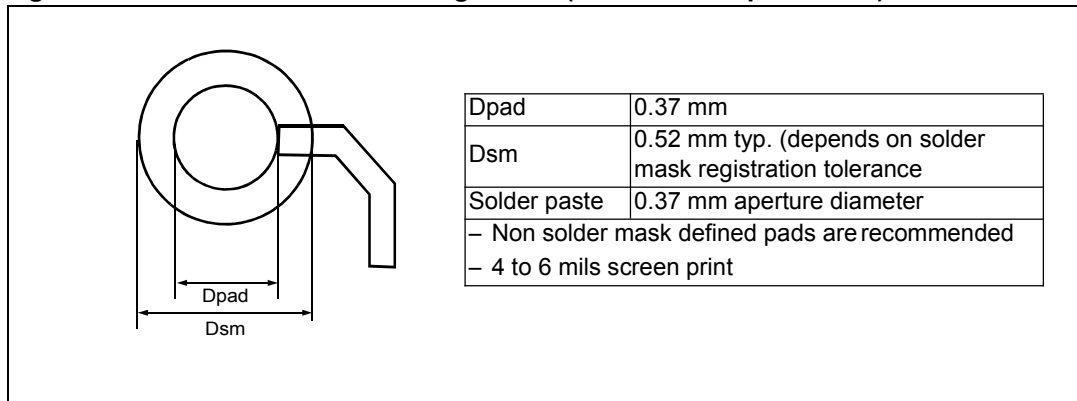
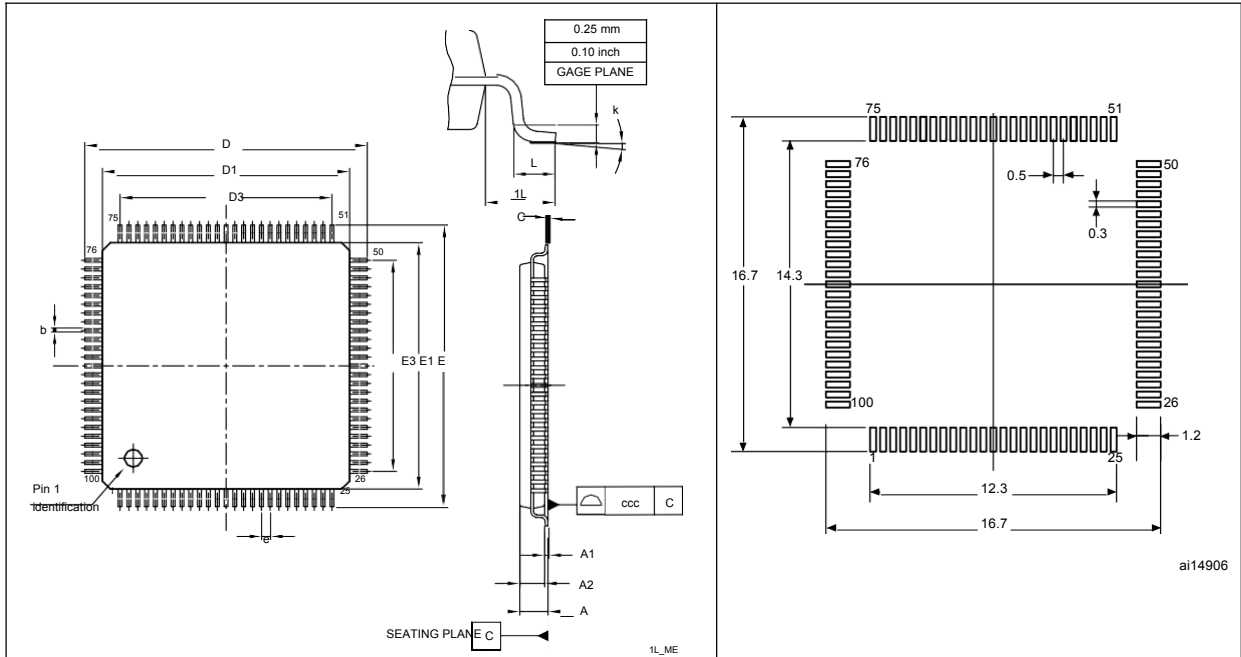



Figure 38. LQFP100, 100-pin low-profile quad flat package outline⁽¹⁾

Figure 39. Recommended footprint⁽¹⁾⁽²⁾



1. Drawing is not to scale.
2. Dimensions are in millimeters.

Table 52. LQFP100, 100-pin low-profile quad flat package mechanical data

Symbol	millimeters			inches ⁽¹⁾		
	Typ	Min	Max	Typ	Min	Max
A			1.6			0.063
A1		0.05	0.15		0.002	0.0059
A2	1.4	1.35	1.45	0.0551	0.0531	0.0571
b	0.22	0.17	0.27	0.0087	0.0067	0.0106
c		0.09	0.2		0.0035	0.0079
D	16	15.8	16.2	0.6299	0.622	0.6378
D1	14	13.8	14.2	0.5512	0.5433	0.5591
D3	12			0.4724		
E	16	15.8	16.2	0.6299	0.622	0.6378
E1	14	13.8	14.2	0.5512	0.5433	0.5591
E3	12			0.4724		
e	0.5			0.0197		
L	0.6	0.45	0.75	0.0236	0.0177	0.0295
L1	1			0.0394		
k	3.5°	0.0°	7.0°	3.5°	0.0°	7.0°
ccc		0.08			0.0031	

†. Values in inches are converted from mm and rounded to 4 decimal digits.

76/91

Doc ID 13587 Rev 10



Figure 40. LQFP64, 64-pin low-profile quad flat package outline⁽¹⁾

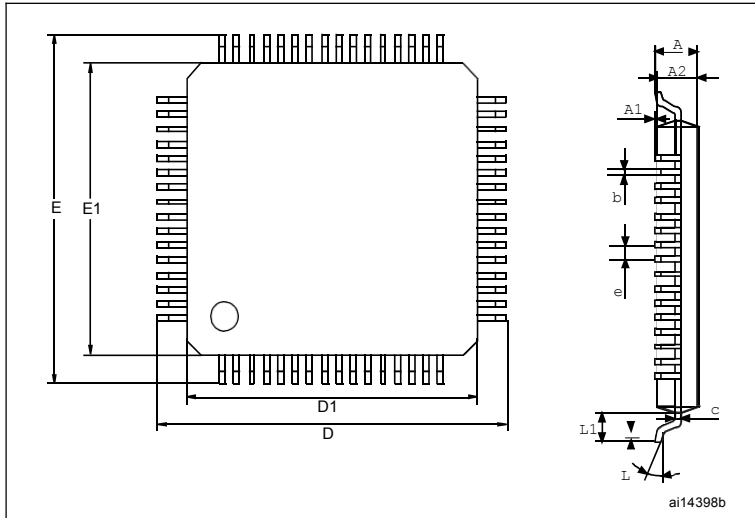
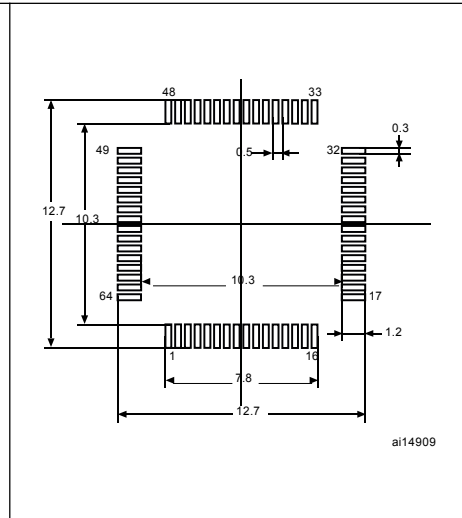

Figure 41. Recommended footprint⁽¹⁾⁽²⁾



1. Drawing is not to scale.
2. Dimensions are in millimeters.

Table 53. LQFP64, 64-pin low-profile quad flat package mechanical data

Dim.	mm			inches ⁽¹⁾		
	Min	Typ	Max	Min	Typ	Max
A			1.60			0.0630
A1	0.05		0.15	0.0020		0.0059
A2	1.35	1.40	1.45	0.0531	0.0551	0.0571
b	0.17	0.22	0.27	0.0067	0.0087	0.0106
c	0.09		0.20	0.0035		0.0079
D		12.00			0.4724	
D1		10.00			0.3937	
E		12.00			0.4724	
E1		10.00			0.3937	
e		0.50			0.0197	
θ	0°	3.5°	7°	0°	3.5°	7°
L	0.45	0.60	0.75	0.0177	0.0236	0.0295
L1		1.00			0.0394	
N	Number of pins					
	64					

1. Values in inches are converted from mm and rounded to 4 decimal digits.



Figure 42. TFBGA64 - 8 x 8 active ball array, 5 x 5 mm, 0.5 mm pitch, package outline

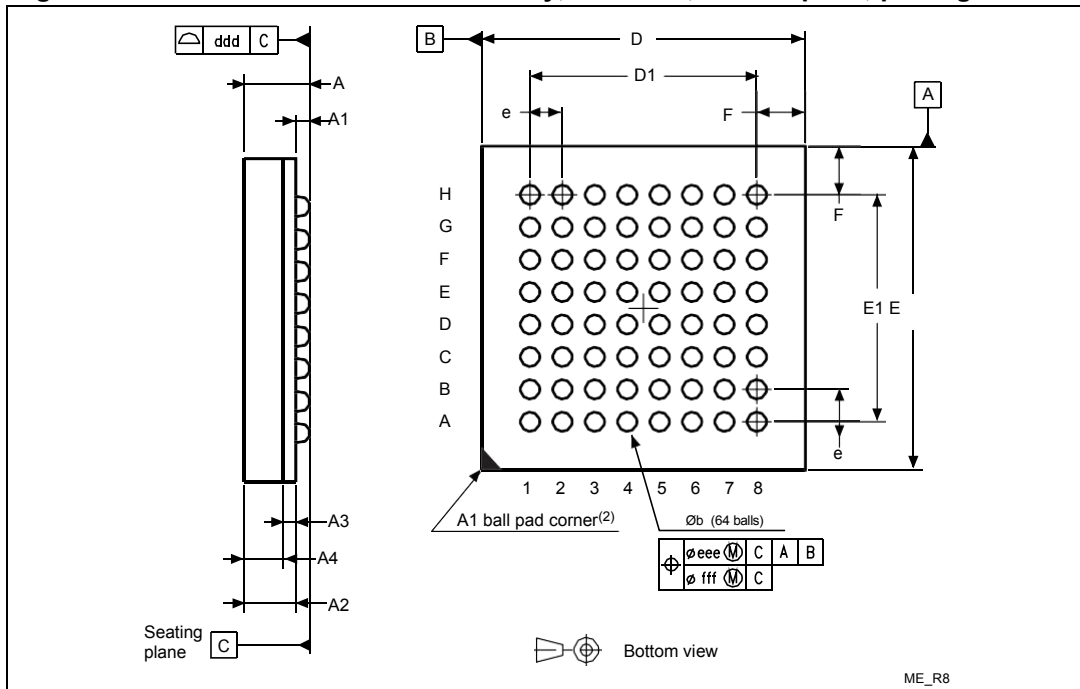

1. Drawing is not to scale.

Table 54. TFBGA64 - 8 x 8 active ball array, 5 x 5 mm, 0.5 mm pitch, package mechanical data

Symbol	millimeters			inches ⁽¹⁾		
	Typ	Min	Max	Typ	Min	Max
A			1.200			0.0472
A1		0.150			0.0059	
A2	0.785			0.0309		
A3	0.200			0.0079		
A4			0.600			0.0236
b	0.300	0.250	0.350	0.0118	0.0098	0.0138
D	5.000	4.850	5.150	0.1969	0.1909	0.2028
D1	3.500			0.1378		
E	5.000	4.850	5.150	0.1969	0.1909	0.2028
E1	3.500			0.1378		
e	0.500			0.0197		
F	0.750			0.0295		
ddd		0.080			0.0031	
eee		0.150			0.0059	
fff		0.050			0.0020	

1. Values in inches are converted from mm and rounded to 4 decimal digits.



Figure 43. Recommended PCB design rules for pads (0.5 mm pitch BGA)

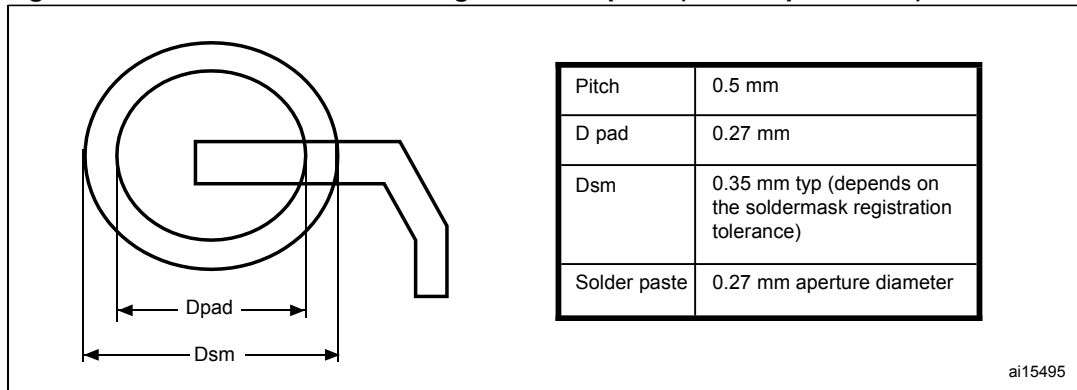

1. Non solder mask defined (NSMD) pads are recommended
2. 4 to 6 mils solder paste screen printing process



Figure 44. LQFP48, 48-pin low-profile quad flat package outline⁽¹⁾

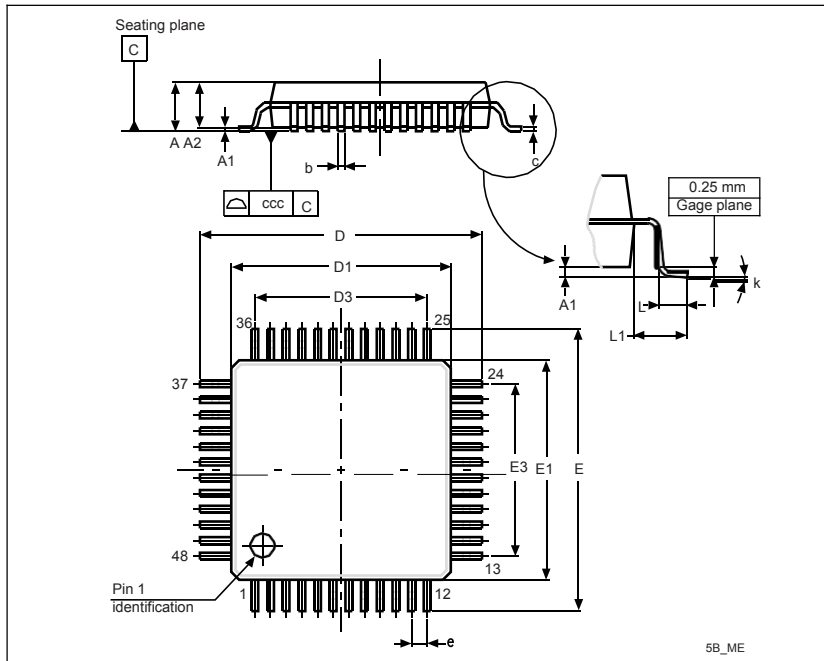
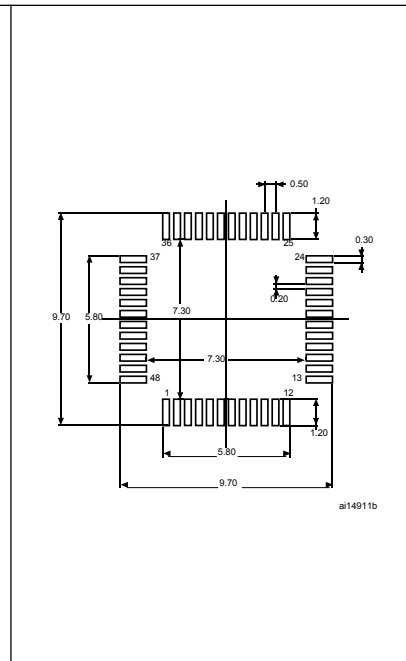

Figure 45. Recommended footprint⁽¹⁾⁽²⁾



1. Drawing is not to scale.
2. Dimensions are in millimeters.

Table 55. LQFP48, 48-pin low-profile quad flat package mechanical data

Symbol	millimeters			inches ⁽¹⁾		
	Typ	Min	Max	Typ	Min	Max
A			1.600			0.0630
A1		0.050	0.150		0.0020	0.0059
A2	1.400	1.350	1.450	0.0551	0.0531	0.0571
b	0.220	0.170	0.270	0.0087	0.0067	0.0106
c		0.090	0.200		0.0035	0.0079
D	9.000	8.800	9.200	0.3543	0.3465	0.3622
D1	7.000	6.800	7.200	0.2756	0.2677	0.2835
D3	5.500			0.2165		
E	9.000	8.800	9.200	0.3543	0.3465	0.3622
E1	7.000	6.800	7.200	0.2756	0.2677	0.2835
E3	5.500			0.2165		
e	0.500			0.0197		
L	0.600	0.450	0.750	0.0236	0.0177	0.0295
L1	1.000			0.0394		
k	3.5°	0°	7°	3.5°	0°	7°
ccc		0.080			0.0031	

1. Values in inches are converted from mm and rounded to 4 decimal digits.



6.2 Thermal characteristics

The maximum chip junction temperature (T_{Jmax}) must never exceed the values given in [Table 9: General operating conditions on page 35](#).

The maximum chip-junction temperature, T_{Jmax} , in degrees Celsius, may be calculated using the following equation:

$$T_{Jmax} = T_{Amax} + (P_{Dmax} \times \Theta_{JA})$$

Where:

- T_{Amax} is the maximum ambient temperature in °C,
- Θ_{JA} is the package junction-to-ambient thermal resistance, in °C/W,
- P_{Dmax} is the sum of P_{INTmax} and $P_{I/Omax}$ ($P_{Dmax} = P_{INTmax} + P_{I/Omax}$),
- P_{INTmax} is the product of I_{DD} and V_{DD} , expressed in Watts. This is the maximum chip internal power.

$P_{I/Omax}$ represents the maximum power dissipation on output pins where:

$$P_{I/Omax} = \Sigma (V_{OL} \times I_{OL}) + \Sigma (V_{DD} - V_{OH}) \times I_{OH},$$

taking into account the actual V_{OL} / I_{OL} and V_{OH} / I_{OH} of the I/Os at low and high level in the application.

Table 56. Package thermal characteristics

Symbol	Parameter	Value	Unit
Θ_{JA}	Thermal resistance junction-ambient LFBGA100 - 10 × 10 mm / 0.8 mm pitch	44	°C/W
	Thermal resistance junction-ambient LQFP100 - 14 × 14 mm / 0.5 mm pitch	46	
	Thermal resistance junction-ambient LQFP64 - 10 × 10 mm / 0.5 mm pitch	45	
	Thermal resistance junction-ambient TFBGA64 - 5 × 5 mm / 0.5 mm pitch	65	
	Thermal resistance junction-ambient LQFP48 - 7 × 7 mm / 0.5 mm pitch	55	
	Thermal resistance junction-ambient VFQFPN 36 - 6 × 6 mm / 0.5 mm pitch	18	

6.2.1 Reference document

JESD51-2 Integrated Circuits Thermal Test Method Environment Conditions - Natural Convection (Still Air). Available from www.jedec.org.



6.2.2 Selecting the product temperature range

When ordering the microcontroller, the temperature range is specified in the ordering information scheme shown in [Table 57: Ordering information scheme](#).

Each temperature range suffix corresponds to a specific guaranteed ambient temperature at maximum dissipation and, to a specific maximum junction temperature.

As applications do not commonly use the STM32F103xx at maximum dissipation, it is useful to calculate the exact power consumption and junction temperature to determine which temperature range will be best suited to the application.

The following examples show how to calculate the temperature range needed for a given application.

Example 1: High-performance application

Assuming the following application conditions:

Maximum ambient temperature $T_{Amax} = 82\text{ °C}$ (measured according to JESD51-2),
 $I_{DDmax} = 50\text{ mA}$, $V_{DD} = 3.5\text{ V}$, maximum 20 I/Os used at the same time in output at low level with $I_{OL} = 8\text{ mA}$, $V_{OL} = 0.4\text{ V}$ and maximum 8 I/Os used at the same time in output at low level with $I_{OL} = 20\text{ mA}$, $V_{OL} = 1.3\text{ V}$

$$P_{INTmax} = 50\text{ mA} \times 3.5\text{ V} = 175\text{ mW}$$

$$P_{IOmax} = 20 \times 8\text{ mA} \times 0.4\text{ V} + 8 \times 20\text{ mA} \times 1.3\text{ V} = 272\text{ mW}$$

This gives: $P_{INTmax} = 175\text{ mW}$ and $P_{IOmax} = 272\text{ mW}$:

$$P_{Dmax} = 175 + 272 = 447\text{ mW}$$

Thus: $P_{Dmax} = 447\text{ mW}$

Using the values obtained in [Table 56](#) T_{Jmax} is calculated as follows:

– For LQFP100, 46 °C/W

$$T_{Jmax} = 82\text{ °C} + (46\text{ °C/W} \times 447\text{ mW}) = 82\text{ °C} + 20.6\text{ °C} = 102.6\text{ °C}$$

This is within the range of the suffix 6 version parts ($-40 < T_J < 105\text{ °C}$).

In this case, parts must be ordered at least with the temperature range suffix 6 (see [Table 57: Ordering information scheme](#)).

Example 2: High-temperature application

Using the same rules, it is possible to address applications that run at high ambient temperatures with a low dissipation, as long as junction temperature T_J remains within the specified range.

Assuming the following application conditions:

Maximum ambient temperature $T_{Amax} = 115\text{ °C}$ (measured according to JESD51-2),
 $I_{DDmax} = 20\text{ mA}$, $V_{DD} = 3.5\text{ V}$, maximum 20 I/Os used at the same time in output at low level with $I_{OL} = 8\text{ mA}$, $V_{OL} = 0.4\text{ V}$

$$P_{INTmax} = 20\text{ mA} \times 3.5\text{ V} = 70\text{ mW}$$

$$P_{IOmax} = 20 \times 8\text{ mA} \times 0.4\text{ V} = 64\text{ mW}$$

This gives: $P_{INTmax} = 70\text{ mW}$ and $P_{IOmax} = 64\text{ mW}$:

$$P_{Dmax} = 70 + 64 = 134\text{ mW}$$

Thus: $P_{Dmax} = 134\text{ mW}$



Using the values obtained in [Table 56](#) T_{Jmax} is calculated as follows:

– For LQFP100, 46 °C/W

$$T_{Jmax} = 115\text{ °C} + (46\text{ °C/W} \times 134\text{ mW}) = 115\text{ °C} + 6.2\text{ °C} = 121.2\text{ °C}$$

This is within the range of the suffix 7 version parts ($-40 < T_J < 125\text{ °C}$).

In this case, parts must be ordered at least with the temperature range suffix 7 (see [Table 57: Ordering information scheme](#)).

Figure 46. LQFP100 P_D max vs. T_A

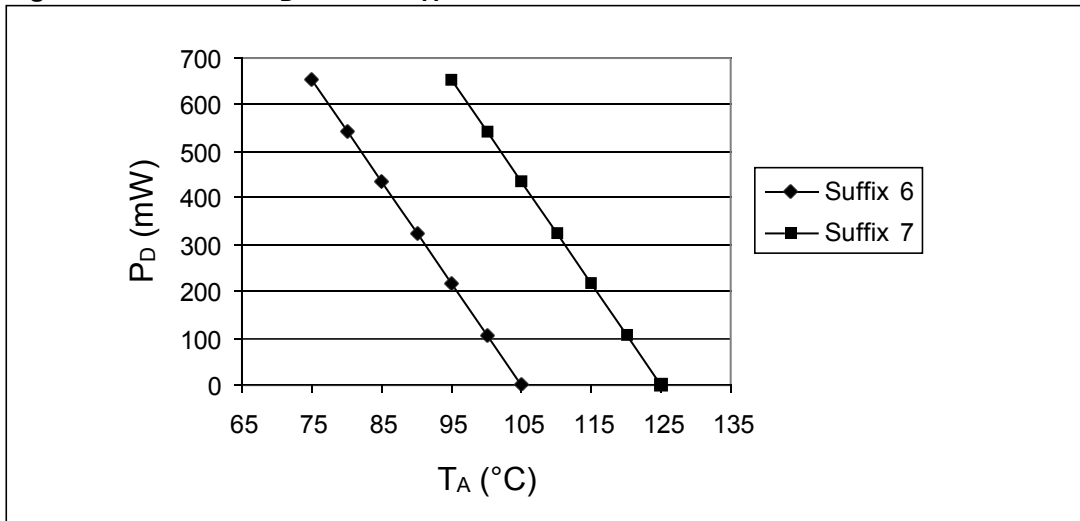



7 Ordering information scheme

Table 57. Ordering information scheme

Example:	STM32	F	103	C	8	T	7	xxx
Device family STM32 = ARM-based 32-bit microcontroller								
Product type F = general-purpose								
Device subfamily 103 = performance line								
Pin count T = 36 pins C = 48 pins R = 64 pins V = 100 pins								
Flash memory size⁽¹⁾ 8 = 64 Kbytes of Flash memory B = 128 Kbytes of Flash memory								
Package H = BGA T = LQFP U = VFQFPN								
Temperature range 6 = Industrial temperature range, -40 to 85 °C. 7 = Industrial temperature range, -40 to 105 °C.								
Options xxx = programmed parts TR = tape and real								

1. Although STM32F103x6 devices are not described in this datasheet, orderable part numbers that do not show the A internal code after temperature range code 6 or 7 should be referred to this datasheet for the electrical characteristics. The low-density datasheet only covers STM32F103x6 devices that feature the A code.

For a list of available options (speed, package, etc.) or for further information on any aspect of this device, please contact your nearest ST sales office.

84/91

Doc ID 13587 Rev 10



8 Revision history

Table 58. Document revision history

Date	Revision	Changes
01-jun-2007	1	Initial release.
20-Jul-2007	2	<p>Flash memory size modified in Note 7, Note 4, Note 7, Note 8 and BGA100 pins added to Table 5: Medium-density STM32F103xx pin definitions. Figure 3: STM32F103xx performance line LFBGA100 ballout added.</p> <p>T_{HSE} changed to T_{LSE} in Figure 20: Low-speed external clock source AC timing diagram. V_{BAT} ranged modified in Power supply schemes. $t_{SU(LSE)}$ changed to $t_{SU(HSE)}$ in Table 22: HSE 4-16 MHz oscillator characteristics. $I_{DD(HSI)}$ max value added to Table 24: HSI oscillator characteristics.</p> <p>Sample size modified and machine model removed in Electrostatic discharge (ESD).</p> <p>Number of parts modified and standard reference updated in Static latch-up. 25 °C and 85 °C conditions removed and class name modified in Table 33: Electrical sensitivities. R_{PU} and R_{PD} min and max values added to Table 34: I/O static characteristics. R_{PU} min and max values added to Table 37: NRST pin characteristics.</p> <p>Figure 25: I²C bus AC waveforms and measurement circuit and Figure 24: Recommended NRST pin protection corrected.</p> <p>Notes removed below Table 9, Table 37, Table 43.</p> <p>I_{DD} typical values changed in Table 11: Maximum current consumption in Run and Sleep modes. Table 38: TIMx characteristics modified.</p> <p>t_{STAB}, V_{REF+} value, t_{lat} and f_{TRIG} added to Table 45: ADC characteristics.</p> <p>In Table 29: Flash memory endurance and data retention, typical endurance and data retention for $T_A = 85$ °C added, data retention for $T_A = 25$ °C removed.</p> <p>V_{BG} changed to V_{REFINT} in Table 12: Embedded internal reference voltage. Document title changed. Controller area network (CAN) section modified.</p> <p>Figure 12: Power supply scheme modified.</p> <p>Features on page 1 list optimized. Small text changes.</p>



Doc ID 13587 Rev 10

85/91



Table 58. Document revision history (continued)

Date	Revision	Changes
18-Oct-2007	3	<p>STM32F103CBT6, STM32F103T6 and STM32F103T8 root part numbers added (see Table 2: STM32F103xx medium-density device features and peripheral counts)</p> <p>VFQFPN36 package added (see Section 6: Package characteristics). All packages are ECOPACK® compliant. Package mechanical data inch values are calculated from mm and rounded to 4 decimal digits (see Section 6: Package characteristics).</p> <p>Table 5: Medium-density STM32F103xx pin definitions updated and clarified.</p> <p>Table 26: Low-power mode wakeup timings updated.</p> <p>T_A min corrected in Table 12: Embedded internal reference voltage.</p> <p>Note 2 added below Table 22: HSE 4-16 MHz oscillator characteristics.</p> <p>$V_{ESD(CDM)}$ value added to Table 32: ESD absolute maximum ratings.</p> <p>Note 3 added and V_{OH} parameter description modified in Table 35: Output voltage characteristics.</p> <p>Note 1 modified under Table 36: I/O AC characteristics.</p> <p>Equation 1 and Table 46: R_{AIN} max for $f_{ADC} = 14$ MHz added to Section 5.3.17: 12-bit ADC characteristics.</p> <p>V_{AIN}, t_S max, t_{CONV}, V_{REF+} min and t_{lat} max modified, notes modified and t_{latr} added in Table 45: ADC characteristics.</p> <p>Figure 30: ADC accuracy characteristics updated. Note 1 modified below Figure 31: Typical connection diagram using the ADC.</p> <p>Electrostatic discharge (ESD) on page 55 modified.</p> <p>Number of TIM4 channels modified in Figure 1: STM32F103xx performance line block diagram.</p> <p>Maximum current consumption Table 13, Table 14 and Table 15 updated. V_{hys} modified in Table 34: I/O static characteristics.</p> <p>Table 48: ADC accuracy updated. t_{VDD} modified in Table 10: Operating conditions at power-up / power-down. V_{FESD} value added in Table 30: EMS characteristics.</p> <p>Values corrected, note 2 modified and note 3 removed in Table 26: Low-power mode wakeup timings.</p> <p>Table 16: Typical and maximum current consumptions in Stop and Standby modes: Typical values added for $V_{DD}/V_{BAT} = 2.4$ V, Note 2 modified, Note 2 added.</p> <p>Table 21: Typical current consumption in Standby mode added. On-chip peripheral current consumption on page 46 added.</p> <p>ACC_{HSI} values updated in Table 24: HSI oscillator characteristics.</p> <p>V_{prog} added to Table 28: Flash memory characteristics.</p> <p>Upper option byte address modified in Figure 9: Memory map.</p> <p>Typical f_{LSI} value added in Table 25: LSI oscillator characteristics and internal RC value corrected from 32 to 40 kHz in entire document.</p> <p>T_{S_temp} added to Table 49: TS characteristics. N_{END} modified in Table 29: Flash memory endurance and data retention.</p> <p>$T_{S_vrefint}$ added to Table 12: Embedded internal reference voltage.</p> <p>Handling of unused pins specified in General input/output characteristics on page 56. All I/Os are CMOS and TTL compliant.</p> <p>Figure 32: Power supply and reference decoupling (V_{REF+} not connected to V_{DDA}) modified.</p> <p>t_{JITTER} and f_{VCO} removed from Table 27: PLL characteristics.</p> <p>Appendix A: Important notes on page 81 added.</p> <p>Added Figure 14, Figure 15, Figure 16 and Figure 18.</p>

Table 58. Document revision history (continued)

86/91

Doc ID 13587 Rev 10



Table 58. Document revision history (continued)

Date	Revision	Changes
22-Nov-2007	4	<p>Document status promoted from preliminary data to datasheet. The STM32F103xx is USB certified. Small text changes.</p> <p><i>Power supply schemes on page 13</i> modified. Number of communication peripherals corrected for STM32F103Tx and number of GPIOs corrected for LQFP package in <i>Table 2: STM32F103xx medium-density device features and peripheral counts</i>.</p> <p>Main function and default alternate function modified for PC14 and PC15 in, <i>Note 5</i> added and Remap column added in <i>Table 5: Medium-density STM32F103xx pin definitions</i>.</p> <p>V_{DD}-V_{SS} ratings and <i>Note 1</i> modified in <i>Table 6: Voltage characteristics</i>, <i>Note 1</i> modified in <i>Table 7: Current characteristics</i>. <i>Note 1</i> and <i>Note 2</i> added in <i>Table 11: Embedded reset and power control block characteristics</i>.</p> <p>I_{DD} value at 72 MHz with peripherals enabled modified in <i>Table 14: Maximum current consumption in Run mode, code with data processing running from RAM</i>.</p> <p>I_{DD} value at 72 MHz with peripherals enabled modified in <i>Table 15: Maximum current consumption in Sleep mode, code running from Flash or RAM on page 41</i>.</p> <p>I_{DD_VBAT} typical value at 2.4 V modified and I_{DD_VBAT} maximum values added in <i>Table 16: Typical and maximum current consumptions in Stop and Standby modes</i>. Note added in <i>Table 17 on page 44</i> and <i>Table 18 on page 45</i>. ADC1 and ADC2 consumption and notes modified in <i>Table 19: Peripheral current consumption</i>.</p> <p>t_{SU(HSE)} and t_{SU(LSE)} conditions modified in <i>Table 22</i> and <i>Table 23</i>, respectively.</p> <p>Maximum values removed from <i>Table 26: Low-power mode wakeup timings</i>. t_{RET} conditions modified in <i>Table 29: Flash memory endurance and data retention</i>. <i>Figure 12: Power supply scheme</i> corrected. <i>Figure 17: Typical current consumption in Stop mode with regulator in Low-power mode versus temperature at V_{DD} = 3.3 V and 3.6 V</i> added. Note removed below <i>Figure 26: SPI timing diagram - slave mode and CPHA = 0</i>. Note added below <i>Figure 27: SPI timing diagram - slave mode and CPHA = 1⁽¹⁾</i>.</p> <p>Details on unused pins removed from <i>General input/output characteristics on page 56</i>.</p> <p><i>Table 41: SPI characteristics</i> updated. <i>Table 42: USB startup time</i> added. V_{AIN}, t_{lat} and t_{latr} modified, note added and I_{IKG} removed in <i>Table 45: ADC characteristics</i>. Test conditions modified and note added in <i>Table 48: ADC accuracy</i>. Note added below <i>Table 46</i> and <i>Table 49</i>.</p> <p>Inch values corrected in <i>Table 52: LQPF100, 100-pin low-profile quad flat package mechanical data</i>, <i>Table 53: LQFP64, 64-pin low-profile quad flat package mechanical data</i> and <i>Table 55: LQFP48, 48-pin low-profile quad flat package mechanical data</i>.</p> <p>Θ_{JA} value for VFQFPN36 package added in <i>Table 56: Package thermal characteristics</i>.</p> <p>Order codes replaced by <i>Section 7: Ordering information scheme</i>.</p> <p>MCU 's operating conditions modified in <i>Typical current consumption on page 44</i>. Avg_Slope and V₂₅ modified in <i>Table 49: TS characteristics</i>. <i>I2C interface characteristics on page 61</i> modified.</p> <p>Impedance size specified in <i>A.4: Voltage glitch on ADC input 0 on page 81</i>.</p>



Table 58. Document revision history (continued)

Doc ID 13587 Rev 10

87/91



Table 58. Document revision history (continued)

Date	Revision	Changes
14-Mar-2008	5	<p>Figure 2: Clock tree on page 20 added.</p> <p>Maximum T_J value given in Table 8: Thermal characteristics on page 35.</p> <p>CRC feature added (see CRC (cyclic redundancy check) calculation unit on page 9 and Figure 9: Memory map on page 31 for address).</p> <p>I_{DD} modified in Table 16: Typical and maximum current consumptions in Stop and Standby modes.</p> <p>ACC_{HSI} modified in Table 24: HSI oscillator characteristics on page 51, note 2 removed.</p> <p>P_D, T_A and T_J added, t_{prog} values modified and t_{prog} description clarified in Table 28: Flash memory characteristics on page 52.</p> <p>t_{RET} modified in Table 29: Flash memory endurance and data retention.</p> <p>$V_{NF(NRST)}$ unit corrected in Table 37: NRST pin characteristics on page 59.</p> <p>Table 41: SPI characteristics on page 63 modified.</p> <p>I_{VREF} added to Table 45: ADC characteristics on page 67.</p> <p>Table 47: ADC accuracy - limited test conditions added. Table 48: ADC accuracy modified.</p> <p>LQFP100 package specifications updated (see Section 6: Package characteristics on page 72).</p> <p>Recommended LQFP100, LQFP 64, LQFP48 and VFQFPN36 footprints added (see Figure 39, Figure 41, Figure 45 and Figure 35).</p> <p>Section 6.2: Thermal characteristics on page 81 modified, Section 6.2.1 and Section 6.2.2 added.</p> <p>Appendix A: Important notes on page 81 removed.</p>
21-Mar-2008	6	<p>Small text changes. Figure 9: Memory map clarified.</p> <p>In Table 29: Flash memory endurance and data retention:</p> <ul style="list-style-type: none"> – N_{END} tested over the whole temperature range – cycling conditions specified for t_{RET} – t_{RET} min modified at $T_A = 55^\circ\text{C}$ <p>V_{25}, Avg_Slope and T_L modified in Table 49: TS characteristics.</p> <p>CRC feature removed.</p>

	Table 58. Document revision history (continued)	Revision number	Description of changes
22-May-2008		7	<p>CRC feature added back. Small text changes. <i>Section 1: Introduction</i> modified. <i>Section 2.2: Full compatibility throughout the family</i> added.</p> <p>I_{DD} at T_A max = 105 °C added to <i>Table 16: Typical and maximum current consumptions in Stop and Standby modes on page 42</i>.</p> <p>I_{DD_VBAT} removed from <i>Table 21: Typical current consumption in Standby mode on page 47</i>.</p> <p>Values added to <i>Table 40: SCL frequency (f_{PCLK1} = 36 MHz., V_{DD} = 3.3 V) on page 62</i>.</p> <p><i>Figure 26: SPI timing diagram - slave mode and CPHA = 0 on page 64</i> modified. <i>Equation 1</i> corrected.</p> <p>t_{RET} at T_A = 105 °C modified in <i>Table 29: Flash memory endurance and data retention on page 53</i>.</p> <p>V_{USB} added to <i>Table 43: USB DC electrical characteristics on page 66</i>. <i>Figure 46: LQFP100 P_D max vs. T_A on page 83</i> modified.</p> <p>Axx option added to <i>Table 57: Ordering information scheme on page 84</i>.</p>

Table 58. Document revision history (continued)

Date	Revision	Changes
21-Jul-2008	8	<p><i>Power supply supervisor</i> updated and V_{DDA} added to <i>Table 9: General operating conditions</i>.</p> <p>Capacitance modified in <i>Figure 12: Power supply scheme on page 33</i>.</p> <p>Table notes revised in <i>Section 5: Electrical characteristics</i>.</p> <p><i>Table 16: Typical and maximum current consumptions in Stop and Standby modes</i> modified.</p> <p>Data added to <i>Table 16: Typical and maximum current consumptions in Stop and Standby modes</i> and <i>Table 21: Typical current consumption in Standby mode</i> removed.</p> <p>f_{HSE_ext} modified in <i>Table 20: High-speed external user clock characteristics on page 47</i>. f_{PLL_IN} modified in <i>Table 27: PLL characteristics on page 52</i>.</p> <p>Minimum SDA and SCL fall time value for Fast mode removed from <i>Table 39: I²C characteristics on page 61</i>, note 1 modified.</p> <p>$t_{h(NSS)}$ modified in <i>Table 41: SPI characteristics on page 63</i> and <i>Figure 26: SPI timing diagram - slave mode and CPHA = 0 on page 64</i>.</p> <p>C_{ADC} modified in <i>Table 45: ADC characteristics on page 67</i> and <i>Figure 31: Typical connection diagram using the ADC</i> modified.</p> <p>Typical T_{S_temp} value removed from <i>Table 49: TS characteristics on page 71</i>.</p> <p>LQFP48 package specifications updated (see <i>Table 55</i> and <i>Table 45</i>), <i>Section 6: Package characteristics</i> revised.</p> <p>Axx option removed from <i>Table 57: Ordering information scheme on page 84</i>.</p> <p>Small text changes.</p>
22-Sep-2008	9	<p>STM32F103x6 part numbers removed (see <i>Table 57: Ordering information scheme</i>). Small text changes.</p> <p><i>General-purpose timers (TIMx)</i> and <i>Advanced-control timer (TIM1)</i> on <i>page 15</i> updated.</p> <p>Notes updated in <i>Table 5: Medium-density STM32F103xx pin definitions on page 26</i>.</p> <p><i>Note 2</i> modified below <i>Table 6: Voltage characteristics on page 34</i>, $\Delta V_{DDx} _{min}$ and $\Delta V_{DDx} _{min}$ removed.</p> <p>Measurement conditions specified in <i>Section 5.3.5: Supply current characteristics on page 38</i>.</p> <p>I_{DD} in standby mode at 85 °C modified in <i>Table 16: Typical and maximum current consumptions in Stop and Standby modes on page 42</i>.</p> <p><i>General input/output characteristics on page 56</i> modified.</p> <p>f_{HCLK} conditions modified in <i>Table 30: EMS characteristics on page 54</i>.</p> <p>Θ_{JA} and pitch value modified for LFBGA100 package in <i>Table 56: Package thermal characteristics</i>. Small text changes.</p>



Table 58. Document revision history (continued)

Doc ID 13587 Rev 10

89/91



Table 58. Document revision history (continued)

Date	Revision	Changes
23-Apr-2009	10	<p>I/O information clarified on page 1.</p> <p>Figure 3: STM32F103xx performance line LFBGA100 ballout modified.</p> <p>Figure 9: Memory map modified. Table 4: Timer feature comparison added.</p> <p>PB4, PB13, PB14, PB15, PB3/TRACESWO moved from Default column to Remap column in Table 5: Medium-density STM32F103xx pin definitions.</p> <p>P_D for LFBGA100 corrected in Table 9: General operating conditions.</p> <p>Note modified in Table 13: Maximum current consumption in Run mode, code with data processing running from Flash and Table 15: Maximum current consumption in Sleep mode, code running from Flash or RAM.</p> <p>Table 20: High-speed external user clock characteristics and Table 21: Low-speed external user clock characteristics modified.</p> <p>Figure 17 shows a typical curve (title modified). ACC_{HSI} max values modified in Table 24: HSI oscillator characteristics.</p> <p>TFBGA64 package added (see Table 54 and Table 42). Small text changes.</p>

90/91 **Table 58. Document revision history (continued)**
Doc ID 13587 Rev 10



Please Read Carefully:

Information in this document is provided solely in connection with ST products. STMicroelectronics NV and its subsidiaries ("ST") reserve the right to make changes, corrections, modifications or improvements, to this document, and the products and services described herein at any time, without notice.

All ST products are sold pursuant to ST's terms and conditions of sale.

Purchasers are solely responsible for the choice, selection and use of the ST products and services described herein, and ST assumes no liability whatsoever relating to the choice, selection or use of the ST products and services described herein.

No license, express or implied, by estoppel or otherwise, to any intellectual property rights is granted under this document. If any part of this document refers to any third party products or services it shall not be deemed a license grant by ST for the use of such third party products or services, or any intellectual property contained therein or considered as a warranty covering the use in any manner whatsoever of such third party products or services or any intellectual property contained therein.

UNLESS OTHERWISE SET FORTH IN ST'S TERMS AND CONDITIONS OF SALE ST DISCLAIMS ANY EXPRESS OR IMPLIED WARRANTY WITH RESPECT TO THE USE AND/OR SALE OF ST PRODUCTS INCLUDING WITHOUT LIMITATION IMPLIED WARRANTIES OF MERCHANTABILITY, FITNESS FOR A PARTICULAR PURPOSE (AND THEIR EQUIVALENTS UNDER THE LAWS OF ANY JURISDICTION), OR INFRINGEMENT OF ANY PATENT, COPYRIGHT OR OTHER INTELLECTUAL PROPERTY RIGHT.

UNLESS EXPRESSLY APPROVED IN WRITING BY AN AUTHORIZED ST REPRESENTATIVE, ST PRODUCTS ARE NOT RECOMMENDED, AUTHORIZED OR WARRANTED FOR USE IN MILITARY, AIR CRAFT, SPACE, LIFE SAVING, OR LIFE SUSTAINING APPLICATIONS, NOR IN PRODUCTS OR SYSTEMS WHERE FAILURE OR MALFUNCTION MAY RESULT IN PERSONAL INJURY, DEATH, OR SEVERE PROPERTY OR ENVIRONMENTAL DAMAGE. ST PRODUCTS WHICH ARE NOT SPECIFIED AS "AUTOMOTIVE GRADE" MAY ONLY BE USED IN AUTOMOTIVE APPLICATIONS AT USER'S OWN RISK.

Resale of ST products with provisions different from the statements and/or technical features set forth in this document shall immediately void any warranty granted by ST for the ST product or service described herein and shall not create or extend in any manner whatsoever, any liability of ST.

ST and the ST logo are trademarks or registered trademarks of ST in various countries.

Information in this document supersedes and replaces all information previously supplied.

The ST logo is a registered trademark of STMicroelectronics. All other names are the property of their respective owners.

© 2009 STMicroelectronics - All rights reserved

STMicroelectronics group of companies

Australia - Belgium - Brazil - Canada - China - Czech Republic - Finland - France - Germany - Hong Kong - India - Israel - Italy - Japan - Malaysia - Malta - Morocco - Philippines - Singapore - Spain - Sweden - Switzerland - United Kingdom - United States of America

www.st.com

