

Features

- **Serial Peripheral Interface (SPI)**
 - Standard SPI: SCLK, /CS, SI, SO, /WP, /HOLD
 - Dual SPI: SCLK, /CS, IO0, IO1, /WP, /HOLD
 - Quad SPI: SCLK, /CS, IO0, IO1, IO2, IO3
- **Read**
 - Normal Read (Serial): 55MHz clock rate
 - Fast Read (Serial): 108MHz clock rate with 30PF load
 - Dual I/O data transfer up to 216Mbits/S
 - Quad I/O data transfer up to 432Mbits/S
 - Continuous Read with 8/16/32/64-byte Wrap
- **Program**
 - Serial-input Page Program up to 256bytes
 - Program Suspend and Resume
- **Erase**
 - Block erase (64/32 KB)
 - Sector erase (4 KB)
 - Chip erase
 - Erase Suspend and Resume
- **Program/Erase Speed**
 - Page Program time: 0.6ms typical
 - Sector Erase time: 50ms typical
 - Block Erase time: 0.15/0.25s typical
 - Chip Erase time: 25s typical
- **Flexible Architecture**
 - Sector of 4K-byte
 - Block of 32/64K-byte
- **Low Power Consumption**
 - 20mA maximum active current
 - 5uA maximum power down current
- **Software/Hardware Write Protection**
 - 3x256-Byte Security Registers with OTP Locks
 - Discoverable Parameters (SFDP) register
 - Enable/Disable protection with WP Pin
 - Write protect all/portion of memory via software
 - Top or Bottom, Sector or Block selection
- **Single Supply Voltage**
 - Full voltage range: 2.7~3.6V
- **Temperature Range**
 - Commercial (0°C to +70°C)
 - Industrial (-40°C to +85°C)
- **Cycling Endurance/Data Retention**
 - Typical 100k Program-Erase cycles on any sector
 - Typical 20-year data retention

Contents

1.	Description.....	4
2.	Signal Description.....	6
	2.1 Input/Output Summary.....	6
	2.2 Chip Select (/CS).....	6
	2.3 Serial Clock (SCLK).....	6
	2.4 Serial Input (SI)/IO0.....	6
	2.5 Serial Data Output (SO)/IO1.....	7
	2.6 Write Protect (/WP)/IO2.....	7
	2.7 HOLD (/HOLD)/IO3.....	7
	2.8 VCC Power Supply.....	8
	2.9 VSS Ground.....	8
3.	Block/Sector Addresses.....	9
4.	SPI Operation.....	10
	4.1 Standard SPI Instructions.....	10
	4.2 Dual SPI Instructions.....	10
	4.3 Quad SPI Instructions.....	10
5.	Operation Features.....	11
	5.1 Supply Voltage.....	11
	5.1.1 Operating Supply Voltage.....	11
	5.1.2 Power-up Conditions.....	11
	5.1.3 Device Reset.....	11
	5.1.4 Power-down.....	11
	5.2 Active Power and Standby Power Modes.....	11
	5.3 Hold Condition.....	11
	5.4 Status Register.....	13
	5.4.1 Status Register Table.....	13
	5.4.2 The Status and Control Bits.....	13
	5.4.3 Status Register Protect Table.....	15
	5.4.4 Write Protect Features.....	15
	5.4.5 Status Register Memory Protection.....	16
6.	Device Identification.....	18
7.	Instructions Description.....	19
	7.1 Configuration and Status Instructions.....	23
	7.1.1 Write Enable (06H).....	23
	7.1.2 Write Disable (04H).....	23
	7.1.3 Read Status Register (05H or 35H or 15H).....	24
	7.1.4 Write Status Register (01H or 31H or 11H).....	24
	7.1.5 Write Enable for Volatile Status Register (50H).....	25
	7.2 Read Instructions.....	26
	7.2.1 Read Data (03H).....	26
	7.2.2 Fast Read (0BH).....	27
	7.2.3 Dual Output Fast Read (3BH).....	28
	7.2.4 Quad Output Fast Read (6BH).....	29
	7.2.5 Dual I/O Fast Read (BBH).....	30
	7.2.6 Quad I/O Fast Read (EBH).....	32
	7.2.7 Quad I/O Word Fast Read (E7H).....	34
	7.2.8 Set Burst with Wrap (77H).....	36
	7.3 ID and Security Instructions.....	37
	7.3.1 Read Manufacture ID/ Device ID (90H).....	37
	7.3.2 Dual I/O Read Manufacture ID/ Device ID (92H).....	38
	7.3.3 Quad I/O Read Manufacture ID/ Device ID (94H).....	39

7.3.4	Read JEDEC ID (9FH).....	40
7.3.5	Read Unique ID Number (4Bh).....	41
7.3.6	Deep Power-Down (B9H).....	42
7.3.7	Release from Deep Power-Down/Read Device ID (ABH).....	43
7.3.8	Read Security Registers (48H).....	44
7.3.9	Erase Security Registers (44H).....	45
7.3.10	Program Security Registers (42H).....	46
7.3.11	Enable Reset (66H) and Reset Device (99H).....	47
7.3.12	Read Serial Flash Discoverable Parameter (5AH).....	48
7.4	Program and Erase Instructions.....	49
7.4.1	Page Program (02H).....	49
7.4.2	Quad Page Program (32H).....	50
7.4.3	Fast Page Program (F2H).....	51
7.4.4	Sector Erase (20H).....	52
7.4.5	32KB Block Erase (52H).....	53
7.4.6	64KB Block Erase (D8H).....	54
7.4.7	Chip Erase (60/C7H).....	55
7.4.8	Erase / Program Suspend (75H).....	56
7.4.9	Erase / Program Resume (7AH).....	57
8.	Electrical Characteristics.....	58
8.1	Absolute Maximum Ratings.....	58
8.2	Operating Ranges.....	58
8.3	Data Retention and Endurance.....	58
8.4	Latch Up Characteristics.....	59
8.5	Power-up Timing.....	59
8.6	DC Electrical Characteristics.....	60
8.7	AC Measurement Conditions.....	61
8.8	AC Electrical Characteristics.....	61
9.	Package Information.....	64
9.1	Package 8-Pin SOP 150-mil.....	64
9.2	Package 8-Pin SOP 208-mil.....	65
9.3	Package 8-Pad WSON (6x5mm).....	66
9.4	Package USON8 (4*3mm).....	67
10.	Order Information.....	68
10.1	Valid part Numbers and Top Side Marking.....	69
10.2	Minimum Packing Quantity (MPQ).....	69
11.	Document Change History.....	70

1. Description

The BY25Q64AS is 64M-bit Serial Peripheral Interface (SPI) Flash memory, and supports the Dual/Quad SPI: Serial Clock, Chip Select, Serial Data I/O0 (SI), I/O1 (SO), I/O2 (/WP), and I/O3 (/HOLD). The Dual I/O data is transferred with speed of 240Mbits/s and the Quad I/O & Quad output data is transferred with speed of 480Mbits/s. The device uses a single low voltage power supply, ranging from 2.7 Volt to 3.6 Volt.

Additionally, the device supports JEDEC standard manufacturer and device ID and three 256-bytes Security Registers.

In order to meet environmental requirements, Boya Microelectronics offers 8-pin SOP 208mil, 8-pad WSON 6x5-mm, and other special order packages, please contacts Boya Microelectronics for ordering information.

Figure 1. Logic diagram

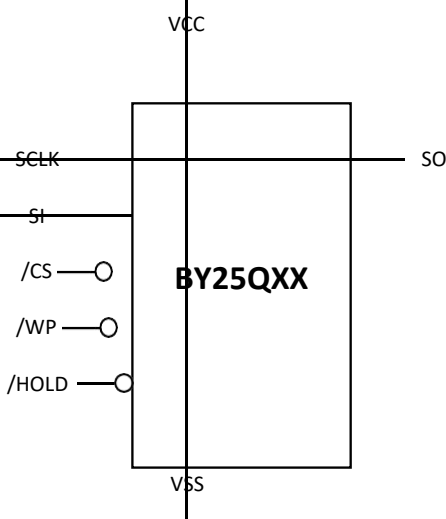

Figure 2. Pin Configuration SOP8

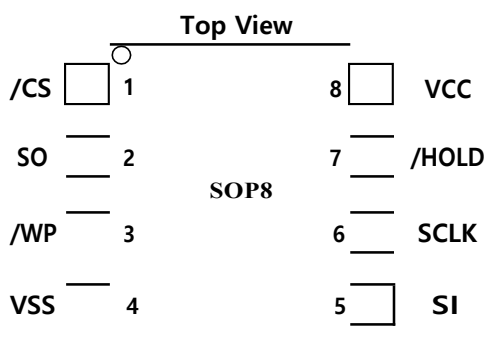

Figure 3.1. Pin Configuration WSON 5*6mm

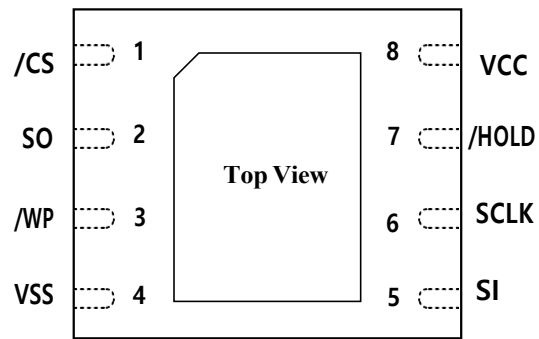
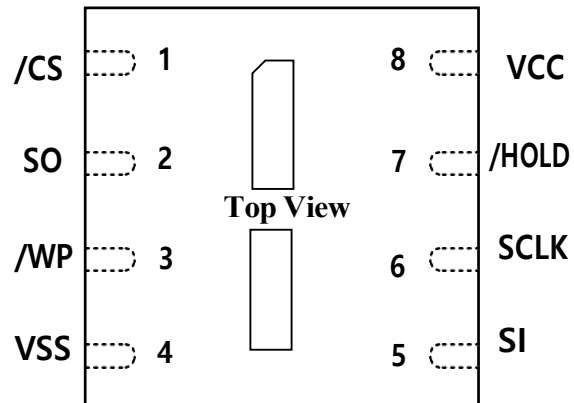

Figure 3.2. Pin Configuration DFN 4*3mm



2. Signal Description

During all operations, VCC must be held stable and within the specified valid range: VCC (min) to VCC (max).

All of the input and output signals must be held High or Low (according to voltages of VIH, VOH, VIL or VOL, see Section 8.6, DC Electrical Characteristics on page 60). These signals are described next.

2.1 Input/Output Summary

Table 1. Signal Names

Pin Name	I/O	Description
/CS	I	Chip Select
SO (IO1)	I/O	Serial Output for single bit data Instructions. IO1 for Dual or Quad Instructions.
/WP (IO2)	I/O	Write Protect in single bit or Dual data Instructions. IO2 in Quad mode. The signal has an internal pull-up resistor and may be left unconnected in the host system if not used for Quad Instructions.
VSS		Ground
SI (IO0)	I/O	Serial Input for single bit data Instructions. IO0 for Dual or Quad Instructions.
SCLK	I	Serial Clock
/HOLD (IO3)	I/O	Hold (pause) serial transfer in single bit or Dual data Instructions. IO3 in Quad-I/O mode. The signal has an internal pull-up resistor and may be left unconnected in the host system if not used for Quad Instructions.
VCC		Core and I/O Power Supply

2.2 Chip Select (/CS)

The chip select signal indicates when an instruction for the device is in process and the other signals are relevant for the memory device. When the /CS signal is at the logic high state, the device is not selected and all input signals are ignored and all output signals are high impedance. Unless an internal Program, Erase or Write Status Registers embedded operation is in progress, the device will be in the Standby Power mode. Driving the /CS input to logic low state enables the device, placing it in the Active Power mode. After Power Up, a falling edge on /CS is required prior to the start of any instruction.

2.3 Serial Clock (SCLK)

This input signal provides the synchronization reference for the SPI interface. Instructions, addresses, or data input are latched on the rising edge of the SCLK signal. Data output changes after the falling edge of SCLK.

2.4 Serial Input (SI)/IO0

This input signal is used to transfer data serially into the device. It receives instructions, addresses, and data to be programmed. Values are latched on the rising edge of serial SCK clock signal.

SI becomes IO0 an input and output during Dual and Quad Instructions for receiving instructions, addresses, and data to be programmed (values latched on rising edge of serial SCK clock signal) as well as shifting out data (on the falling edge of SCK).

2.5 Serial Data Output (SO)/IO1

This output signal is used to transfer data serially out of the device. Data is shifted out on the falling edge of the serial SCK clock signal.

SO becomes IO1 an input and output during Dual and Quad Instructions for receiving instructions, addresses, and data to be programmed (values latched on rising edge of serial SCK clock signal) as well as shifting out data (on the falling edge of SCK).

2.6 Write Protect (/WP)/IO2

When /WP is driven Low (VIL), while the Status Register Protect bits (SRP1 and SRP0) of the Status Registers (SR2[0] and SR1[7]) are set to 0 and 1 respectively, it is not possible to write to the Status Registers. This prevents any alteration of the Status Registers. As a consequence, all the data bytes in the memory area that are protected by the Block Protect, TB, SEC, and CMP bits in the status registers, are also hardware protected against data modification while /WP remains Low. The /WP function is not available when the Quad mode is enabled (QE) in Status Register 2 (SR2[1]=1).

The /WP function is replaced by IO2 for input and output during Quad mode for receiving addresses, and data to be programmed (values are latched on rising edge of the SCK signal) as well as shifting out data (on the falling edge of SCK). /WP has an internal pull-up resistance; when unconnected; /WP is at VIH and may be left unconnected in the host system if not used for Quad mode.

2.7 HOLD (/HOLD)/IO3

The /HOLD function is only available when QE=0, If QE=1, The /HOLD function is disabled, the pin acts as dedicated data I/O pin

The /HOLD signal goes low to stop any serial communications with the device, but doesn't stop the operation of write status register, programming, or erasing in progress.

The operation of HOLD, need /CS keep low, and starts on falling edge of the /HOLD signal, with SCLK signal being low (if SCLK is not being low, HOLD operation will not start until SCLK being low). The HOLD condition ends on rising edge of /HOLD signal with SCLK being low (If SCLK is not being low, HOLD operation will not end until SCLK being low).

The Hold condition starts on the falling edge of the Hold (/HOLD) signal, provided that this coincides with SCK being at the logic low state. If the falling edge does not coincide with the SCK signal being at the logic low state, the Hold condition starts whenever the SCK signal reaches the logic low state. Taking the /HOLD signal to the logic low state does not terminate any Write, Program or Erase operation that is currently in progress.

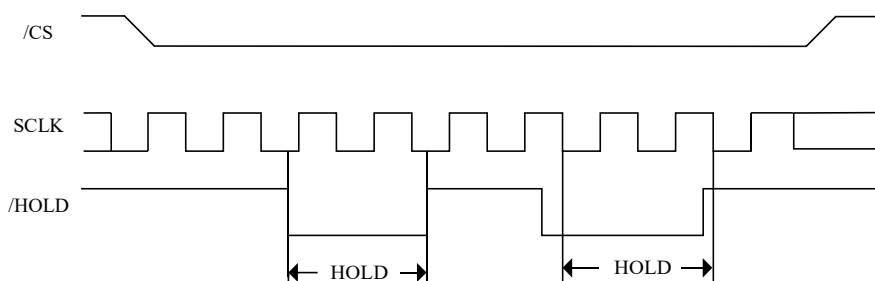

2.8 VCC Power Supply

VCC is the supply voltage. It is the single voltage used for all device functions including read, program, and erase.

2.9 VSS Ground

VSS is the reference for the VCC supply voltage.

3. Block/Sector Addresses

Table 2. Block/Sector Addresses of BY25Q64AS

Memory Density	Block(64k byte)	Block(32k byte)	Sector No.	Sector Size(KB)	Address range	
64Mbit	Block 0	Half block 0	Sector 0	4	000000h-000FFFh	
			:	:	:	
			Sector 7	4	007000h-007FFFh	
		Half block 1	Sector 8	4	008000h-008FFFh	
			:	4	:	
			Sector 15	4	00F000h-00FFFFh	
	Block 1	Half block 2	Sector 16	4	010000h-010FFFh	
			:	:	:	
			Sector 23	4	017000h-017FFFh	
		Half block 3	Sector 24	4	018000h-018FFFh	
			:	:	:	
			Sector 31	4	01F000h-01FFFFh	
	:	:	:	:	:	:
	Block 126	Half block 250	Sector 2016	4	7E0000h-7E0FFFh	
			:	:	:	
			Sector 2023	4	7E7000h-7E7FFFh	
		Half block 251	Sector 2024	4	7E8000h-7E8FFFh	
			:	:	:	
			Sector 2031	4	7EF000h-7EFFFFh	
	Block 127	Half block 252	Sector 2032	4	7F0000h-7F0FFFh	
			:	:	:	
			Sector 2039	4	7F7000h-7F7FFFh	
		Half block 253	Sector 2040	4	3F8000h-3F8FFFh	
			:	:	:	
			Sector 2047	4	7FF000h-7FFFFFFh	

Notes:

1. Block = Uniform Block, and the size is 64K bytes.
2. Half block = Half Uniform Block, and the size is 32k bytes.
3. Sector = Uniform Sector, and the size is 4K bytes.

4. SPI Operation

4.1 Standard SPI Instructions

The BY25Q64AS features a serial peripheral interface on 4 signals bus: Serial Clock (SCLK), Chip Select (/CS), Serial Data Input (SI) and Serial Data Output (SO). Both SPI bus mode 0 and 3 are supported. Input data is latched on the rising edge of SCLK and data shifts out on the falling edge of SCLK.

4.2 Dual SPI Instructions

The BY25Q64AS supports Dual SPI operation when using the “Dual Output Fast Read” (3BH), “Dual I/O Fast Read” (BBH) and “Read Manufacture ID/Device ID Dual I/O” (92H) instructions. These instructions allow data to be transferred to or from the device at two times the rate of the standard SPI. When using the Dual SPI instruction the SI and SO pins become bidirectional I/O pins: IO0 and IO1.

4.3 Quad SPI Instructions

The BY25Q64AS supports Quad SPI operation when using the “Quad Output Fast Read”(6BH), “Quad I/O Fast Read” (EBH) ,”Quad I/O word Fast Read”(E7H),”Read Manufacture ID/Device ID Quad I/O”(94H) and “Quad Page Program”(32H) instructions. These instructions allow data to be transferred to or from the device at four times the rate of the standard SPI. When using the Quad SPI instruction the SI and SO pins become bidirectional I/O pins: IO0 and IO1, and /WP and /HOLD pins become IO2 and IO3. Quad SPI instructions require the non-volatile Quad Enable bit (QE) in Status Register to be set.

5. Operation Features

5.1 Supply Voltage

5.1.1 Operating Supply Voltage

Prior to selecting the memory and issuing instructions to it, a valid and stable VCC voltage within the specified [VCC(min), VCC(max)] range must be applied (see operating ranges of *page 58*). In order to secure a stable DC supply voltage, it is recommended to decouple the VCC line with a suitable capacitor (usually of the order of 10nF to 100nF) close to the VCC/VSS package pins. This voltage must remain stable and valid until the end of the transmission of the instruction and, for a Write instruction, until the completion of the internal write cycle (tW).

5.1.2 Power-up Conditions

When the power supply is turned on, VCC rises continuously from VSS to VCC. During this time, the Chip Select (/CS) line is not allowed to float but should follow the VCC voltage, it is therefore recommended to connect the /CS line to VCC via a suitable pull-up resistor.

In addition, the Chip Select (/CS) input offers a built-in safety feature, as the /CS input is edge sensitive as well as level sensitive: after power-up, the device does not become selected until a falling edge has first been detected on Chip Select (/CS). This ensures that Chip Select (/CS) must have been High, prior to going Low to start the first operation.

5.1.3 Device Reset

In order to prevent inadvertent Write operations during power-up (continuous rise of VCC), a power on reset (POR) circuit is included. At Power-up, the device does not respond to any instruction until VCC has reached the power on reset threshold voltage (this threshold is lower than the minimum VCC operating voltage defined in operating ranges of *page 58*).

When VCC has passed the POR threshold, the device is reset.

5.1.4 Power-down

At Power-down (continuous decrease in VCC), as soon as VCC drops from the normal operating voltage to below the power on reset threshold voltage, the device stops responding to any instruction sent to it. During Power-down, the device must be deselected (Chip Select (/CS) should be allowed to follow the voltage applied on VCC) and in Standby Power mode (that is there should be no internal Write cycle in progress).

5.2 Active Power and Standby Power Modes

When Chip Select (/CS) is Low, the device is selected, and in the Active Power mode. The device consumes ICC.

When Chip Select (/CS) is High, the device is deselected. If a Write cycle is not currently in progress, the device then goes in to the Standby Power mode, and the device consumption drops to ICC1.

5.3 Hold Condition

The Hold (/HOLD) signal is used to pause any serial communications with the device without resetting the clocking sequence. During the Hold condition, the Serial Data Output (SO) is high impedance, and Serial Data Input (SI) and Serial Clock (SCLK) are Don't Care. To enter the Hold condition, the device must be selected, with Chip Select (/CS) Low. Normally, the device is kept selected, for the whole duration of the Hold condition. Deselecting the device while it is in the Hold

condition, has the effect of resetting the state of the device, and this mechanism can be used if it is required to reset any processes that had been in progress.

The Hold condition starts when the Hold (/HOLD) signal is driven Low at the same time as Serial Clock (SCLK) already being Low (as shown in *Figure 4*). The Hold condition ends when the Hold (/HOLD) signal is driven High at the same time as Serial Clock (C) already being Low. *Figure 4* also shows what happens if the rising and falling edges are not timed to coincide with Serial Clock (SCLK) being Low.

Figure 4. Hold condition activation

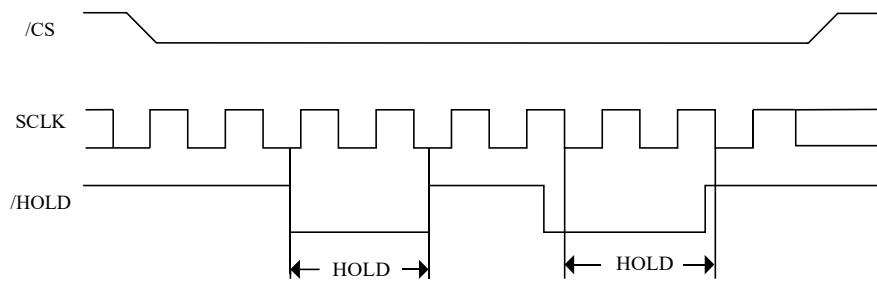

5.4 Status Register

5.4.1 Status Register Table

See [Table 3](#) for detail description of the Status Register bits.

Table 3. Status Register

S23	S22	S21	S20	S19	S18	S17	S16
Reserved	DRV1	DRV0	Reserved	Reserved	Reserved	Reserved	Reserved

S15	S14	S13	S12	S11	S10	S9	S8
SUS1	CMP	LB3	LB2	LB1	SUS2	QE	SRP1

S7	S6	S5	S4	S3	S2	S1	S0
SRP0	BP4	BP3	BP2	BP1	BP0	WEL	WIP

5.4.2 The Status and Control Bits

5.4.2.1 WIP bit

The Write in Progress (WIP) bit indicates whether the memory is busy in program/erase/write status register progress. When WIP bit sets to 1, means the device is busy in program/erase/write status register progress, when WIP bit sets 0, means the device is not in program/erase/write status register progress.

5.4.2.2 WEL bit

The Write Enable Latch bit indicates the status of the internal Write Enable Latch. When set to 1 the internal Write Enable Latch is set, when set to 0 the internal Write Enable Latch is reset and no Write Status Register, Program or Erase instruction is accepted.

5.4.2.3 BP4, BP3, BP2, BP1, BP0 bits

The Block Protect (BP4, BP3, BP2, BP1, BP0) bits are non-volatile. They define the size of the area to be software protected against Program and Erase instructions. These bits are written with the Write Status Register instruction. When the Block Protect (BP4, BP3, BP2, BP1, BP0) bits are set to 1, the relevant memory area (as defined in [Table 6](#) and [Table 7](#)), becomes protected against Page Program, Sector Erase and Block Erase instructions. The Block Protect (BP4, BP3, BP2, BP1, BP0) bits can be written provided that the Hardware Protected mode has not been set. The Chip Erase(CE) instruction is executed, if the Block Protect(BP2,BP1,BP0)bits are 0 and CMP=0 or The Block Protect (BP2, BP1, BP0) bits are 1 and CMP=1.

5.4.2.4 SRP1, SRP0 bits

The Status Register Protect (SRP1 and SRP0) bits are non-volatile Read/Write bits in the status register. The SRP bits control the method of write protection: software protection, hardware protection, power supply lock-down or one time programmable protection.

5.4.2.5 QE bit

The Quad Enable (QE) bit is a non-volatile Read/Write bit in the Status Register that allows Quad operation. When the QE bit is set to 0 (Default) the /WP pin and /HOLD pin are enable. When the QE pin is set to 1, the Quad IO2 and IO3 pins are enabled. (The QE bit should never be set to 1 during standard SPI or Dual SPI operation if the /WP or /HOLD pins directly to the power supply or ground).

5.4.2.6 LB3/LB2/LB1 bit

The LB bit is a non-volatile One Time Program (OTP) bit in Status Register (S13–S11) that provide the write protect control and status to the Security Registers. The default state of LB is 0, the security registers are unlocked. LB can be set to 1 individually using the Write Register instruction. LB is One Time Programmable, once they are set to 1, the Security Registers will become read-only permanently.

5.4.2.7 CMP bit

The CMP bit is a non-volatile Read/Write bit in the Status Register (S14). It is used in conjunction the SEC-BP0 bits to provide more flexibility for the array protection. Please see the Status registers Memory Protection table for details. The default setting is CMP=0.

5.4.2.8 SUS1/SUS2 bit

The SUS1 and SUS2 bits are read only bits in the status register2 (S15 and S10) that are set to 1 after executing an Erase/Program Suspend (75H) instruction (The Erase Suspend will set SUS1 to 1, and the Program Suspend will set the SUS2 to 1). The SUS1 and SUS2 bits are cleared to 0 by Erase/Program Resume (7AH) instruction as well as a power-down, power-up cycle.

5.4.2.9 DRV1/DRV0

The DRV1&DRV0 bits are used to determine the output driver strength for the Read instruction.

DRV1, DRV0	Driver Strength
00	100%(default)
01	75%
10	50%
11	25%

5.4.3 Status Register Protect Table

The Status Register Protect (SRP1 and SRP0) bits are non-volatile Read/Write bits in the Status Register. The SRP bits control the method of write protection: software protection, hardware protection, power supply lock-down or one time programmable protection.

Table 4. Status Register protect table

SRP1	SRP0	/WP	Status Register	Description
0	0	X	Software Protected	The Status Register can be written to after a Write Enable instruction, WEL=1. (Factory Default)
0	1	0	Hardware Protected	/WP=0, the Status Register locked and cannot be written.
0	1	1	Hardware Unprotected	/WP=1, the Status Register is unlocked and can be written to after a Write Enable instruction, WEL=1.
1	0	X	Power Supply Lock-Down ⁽¹⁾	Status Register is protected and cannot be written to again until the next Power-Down, Power-Up cycle.
1	1	X	One Time Program ⁽²⁾	Status Register is permanently protected and cannot be written to.

Notes:

1. When SRP1, SRP0= (1, 0), a Power-Down, Power-Up cycle will change SRP1, SRP0 to (0, 0) state.
2. The One time Program feature is available upon special order. Please contact Boya Microelectronics for details.

5.4.4 Write Protect Features

1. Software Protection: The Block Protect (BP4, BP3, BP2, BP1, BP0) bits define the section of the memory array that can be read but not change.
2. Hardware Protection: /WP going low to protect the writable bits of Status Register.
3. Deep Power-Down: In Deep Power-Down Mode, all instructions are ignored except the Release from deep Power-Down Mode instruction.
4. Write Enable: The Write Enable instruction is set the Write Enable Latch bit. The WEL bit will return to reset by following situation:
 - Power –up
 - Write Disable
 - Write Status Register
 - Page Program
 - Sector Erase/Block Erase/Chip Erase
 - Software Reset

5.4.5 Status Register Memory Protection
5.4.5.1 Protect Table
Table 5. BY25Q64AS Status Register Memory Protection (CMP=0)

Status Register Content					Memory Content			
BP4	BP3	BP2	BP1	BP0	Blocks	Addresses	Density	Portion
X	X	0	0	0	NONE	NONE	NONE	NONE
0	0	0	0	1	126 to 127	7E0000H-7FFFFFFH	128KB	Upper 1/64
0	0	0	1	0	124 to 127	7C0000H-7FFFFFFH	256KB	Upper 1/32
0	0	0	1	1	120 to 127	780000H-7FFFFFFH	512KB	Upper 1/16
0	0	1	0	0	112 to 127	700000H-7FFFFFFH	1MB	Upper 1/8
0	0	1	0	1	96 to 127	600000H-7FFFFFFH	2MB	Upper 1/4
0	0	1	1	0	64 to 127	400000H-7FFFFFFH	4MB	Upper 1/2
0	1	0	0	1	0 to 1	000000H-01FFFFH	128KB	Lower 1/64
0	1	0	1	0	0 to 3	000000H-03FFFFH	256KB	Lower 1/32
0	1	0	1	1	0 to 7	000000H-07FFFFH	512KB	Lower 1/16
0	1	1	0	0	0 to 15	000000H-0FFFFFFH	1MB	Lower 1/8
0	1	1	0	1	0 to 31	000000H-1FFFFFFH	2MB	Lower 1/4
0	1	1	1	0	0 to 63	000000H-3FFFFFFH	4MB	Lower 1/2
X	X	1	1	1	0 to 127	000000H-7FFFFFFH	8MB	ALL
1	0	0	0	1	127	7FF000H-7FFFFFFH	4KB	Top Block
1	0	0	1	0	127	7FE000H-7FFFFFFH	8KB	Top Block
1	0	0	1	1	127	7FC000H-7FFFFFFH	16KB	Top Block
1	0	1	0	X	127	7F8000H-7FFFFFFH	32KB	Top Block
1	0	1	1	0	127	7F8000H-7FFFFFFH	32KB	Top Block
1	1	0	0	1	0	000000H-000FFFH	4KB	Bottom Block
1	1	0	1	0	0	000000H-001FFFH	8KB	Bottom Block
1	1	0	1	1	0	000000H-003FFFH	16KB	Bottom Block
1	1	1	0	X	0	000000H-007FFFH	32KB	Bottom Block
1	1	1	1	0	0	000000H-007FFFH	32KB	Bottom Block

Table 6 BY25Q64AS Status Register Memory Protection (CMP=1)

Status Register Content					Memory Content			
BP4	BP3	BP2	BP1	BP0	Blocks	Addresses	Density	Portion
X	X	0	0	0	ALL	000000H-7FFFFFFH	ALL	ALL
0	0	0	0	1	0 to 125	000000H-7DFFFFFFH	8064KB	Lower 63/64
0	0	0	1	0	0 to 123	000000H-7BFFFFFFH	7936KB	Lower 31/32
0	0	0	1	1	0 to 119	000000H-77FFFFFFH	7680KB	Lower 15/16
0	0	1	0	0	0 to 111	000000H-6FFFFFFH	7MB	Lower 7/8
0	0	1	0	1	0 to 95	000000H-5FFFFFFH	6MB	Lower 3/4
0	0	1	1	0	0 to 63	000000H-3FFFFFFH	4MB	Lower 1/2
0	1	0	0	1	2 to 127	020000H-7FFFFFFH	8064KB	Upper 63/64
0	1	0	1	0	4 to 127	040000H-7FFFFFFH	7936KB	Upper 31/32
0	1	0	1	1	8 to 127	080000H-7FFFFFFH	7680KB	Upper 15/16
0	1	1	0	0	16 to 127	100000H-7FFFFFFH	7MB	Upper 7/8
0	1	1	0	1	32 to 127	200000H-7FFFFFFH	6MB	Upper 3/4
0	1	1	1	0	64 to 127	400000H-7FFFFFFH	4MB	Upper 1/2
X	X	1	1	1	NONE	NONE	NONE	NONE
1	0	0	0	1	0 to 127	000000H-7FEFFFFH	8188KB	L-2047/2048
1	0	0	1	0	0 to 127	000000H-7FDFFFFH	8184KB	L-1023/1024
1	0	0	1	1	0 to 127	000000H-7FBFFFFH	8176KB	L-511/512
1	0	1	0	X	0 to 127	000000H-7F7FFFFH	8160KB	L-255/256
1	0	1	1	0	0 to 127	000000H-7F7FFFFH	8160KB	L-255/256
1	1	0	0	1	0 to 127	001000H-7FFFFFFH	8188KB	U-2047/2048
1	1	0	1	0	0 to 127	002000H-7FFFFFFH	8184KB	U-1023/1024
1	1	0	1	1	0 to 127	004000H-7FFFFFFH	8176KB	U-511/512
1	1	1	0	X	0 to 127	008000H-7FFFFFFH	8160KB	U-255/256
1	1	1	1	0	0 to 127	008000H-7FFFFFFH	8160KB	U-255/256

6. Device Identification

Three legacy Instructions are supported to access device identification that can indicate the manufacturer, device type, and capacity (density). The returned data bytes provide the information as shown in the below table.

Table 7. BY25Q64AS ID Definition table

Operation Code	M7-M0	ID15-ID8	ID7-ID0
9FH	68	40	17
90H/92H/94H	68		16
ABH			16

7. Instructions Description

All instructions, addresses and data are shifted in and out of the device, beginning with the most significant bit on the first rising edge of SCLK after /CS is driven low. Then, the one byte instruction code must be shifted in to the device, most significant bit first on SI, each bit being latched on the rising edges of SCLK.

See [Table 8](#), every instruction sequence starts with a one-byte instruction code. Depending on the instruction, this might be followed by address bytes, or by data bytes, or by both or none. /CS must be driven high after the last bit of the instruction sequence has been shifted in. For the instruction of Read, Fast Read, Read Status Register or Release from Deep Power Down, and Read Device ID, the shifted-in instruction sequence is followed by a data out sequence. /CS can be driven high after any bit of the data-out sequence is being shifted out.

For the instruction of Page Program, Sector Erase, Block Erase, Chip Erase, Write Status Register, Write Enable, Write Disable or Deep Power-Down instruction, /CS must be driven high exactly at a byte boundary, otherwise the instruction is rejected, and is not executed. That is /CS must driven high when the number of clock pulses after /CS being driven low is an exact multiple of eight. For Page Program, if at any time the input byte is not a full byte, nothing will happen and WEL will not be reset.

Table 8. Instruction Set Table

Instruction Name	Byte 1	Byte 2	Byte 3	Byte 4	Byte 5	Byte 6	N-Bytes
Write Enable	06H						
Write Disable	04H						
Read Status Register-1	05H	(S7-S0)					continuous
Read Status Register-2	35H	(S15-S8)					continuous
Read Status Register-3	15H	(S23-S16)					continuous
Write Enable for Volatile Status Register	50H						
Write Status Register -1	01H	(S7-S0)					
Write Status Register-2	31H	(S15-S8)					
Write Status Register-3	11H	(S23-S16)					
Read Data	03H	A23-A16	A15-A8	A7-A0	(D7-D0)	Next byte	continuous
Fast Read	0BH	A23-A16	A15-A8	A7-A0	dummy	(D7-D0)	continuous
Dual Output Fast Read	3BH	A23-A16	A15-A8	A7-A0	dummy	(D7-D0) ⁽¹⁾	continuous
Dual I/O Fast Read	BBH	A23-A8 ⁽²⁾	A7-A0 M7-M0 ⁽²⁾	(D7-D0) ⁽¹⁾	Next byte	Next byte	continuous
Quad Output Fast Read	6BH	A23-A16	A15-A8	A7-A0	dummy	(D7-D0) ⁽³⁾	continuous
Quad I/O Fast Read	EBH	A23-A0 M7-M0 ⁽⁴⁾	dummy ⁽⁵⁾	(D7-D0) ⁽³⁾	Next byte	Next byte	continuous
Quad I/O Word Fast Read ⁽⁷⁾	E7H	A23-A0 dM7-M0 ⁽⁴⁾	dummy ⁽⁶⁾	(D7-D0) ⁽³⁾	Next byte	Next byte	continuous
Page Program	02H	A23-A16	A15-A8	A7-A0	(D7-D0)	Next byte	continuous
Quad Page Program	32H	A23-A16	A15-A8	A7-A0	(D7-D0) ⁽³⁾	Next byte	continuous
Fast Page Program	F2H	A23-A16	A15-A8	A7-A0	(D7-D0)	Next byte	continuous
Sector Erase	20H	A23-A16	A15-A8	A7-A0			
Block Erase(32K)	52H	A23-A16	A15-A8	A7-A0			
Block Erase(64K)	D8H	A23-A16	A15-A8	A7-A0			
Chip Erase	C7/60H						
Enable Reset	66H						
Reset	99H						
Set Burst with Wrap	77H	dummy ⁽⁶⁾ W7-W0					
Program/Erase Suspend	75H						
Program/Erase Resume	7AH						
Deep Power-Down	B9H						
Release From Deep Power-Down, And Read Device ID	ABH	dummy	dummy	dummy	(ID7-ID0)		continuous
Release From Deep Power-Down	ABH						
Manufacturer/	90H	dummy	dummy	00H	(MID7-MID0)	(ID7-ID0)	continuous

Device ID							
Manufacturer/ Device ID by Dual I/O	92H	A23-A8	A7-A0, dummy	(MID7-MID0) ,(DID7-DID0)			continuous
Manufacturer/ Device ID by Quad I/O	94H	A23-A0, dummy	dummy ⁽¹⁰⁾ (MID7-MID0) (DID7-DID0)				continuous
JEDEC ID	9FH	MID7-MID 0	ID15-ID8	ID7-ID0			continuous
Read Serial Flash Discoverable Parameter	5AH	A23-A16	A15-A8	A7-A0	Dummy	D7-D0	continuous
Erase Security Registers ⁽⁸⁾	44H	A23-A16	A15-A8	A7-A0			
Program Security Registers ⁽⁸⁾	42H	A23-A16	A15-A8	A7-A0	(D7-D0)	(D7-D0)	continuous
Read Security Registers ⁽⁸⁾	48H	A23-A16	A15-A8	A7-A0	dummy	(D7-D0)	continuous

Notes:

1. Dual Output data
IO0 = (D6, D4, D2, D0)
IO1 = (D7, D5, D3, D1)
2. Dual Input Address
IO0 = A22, A20, A18, A16, A14, A12, A10, A8, A6, A4, A2, A0, M6, M4, M2, M0
IO1 = A23, A21, A19, A17, A15, A13, A11, A9, A7, A5, A3, A1, M7, M5, M3, M1
3. Quad Output Data
IO0 = (D4, D0,.....)
IO1 = (D5, D1,.....)
IO2 = (D6, D2,.....)
IO3 = (D7, D3,.....)
4. Quad Input Address
IO0 = A20, A16, A12, A8, A4, A0, M4, M0
IO1 = A21, A17, A13, A9, A5, A1, M5, M1
IO2 = A22, A18, A14, A10, A6, A2, M6, M2
IO3 = A23, A19, A15, A11, A7, A3, M7, M3
5. Fast Read Quad I/O Data
IO0 = (x, x, x, x, D4, D0,...)
IO1 = (x, x, x, x, D5, D1,...)
IO2 = (x, x, x, x, D6, D2,...)
IO3 = (x, x, x, x, D7, D3,...)
6. Fast Word Read Quad I/O Data
IO0 = (x, x, D4, D0,...)
IO1 = (x, x, D5, D1,...)
IO2 = (x, x, D6, D2,...)
IO3 = (x, x, D7, D3,...)
7. Fast Word Read Quad I/O Data: the lowest address bit must be 0.
8. Security Registers Address:
Security Register1: A23-A16=00H, A15-A8=00010000b, A7-A0= Byte Address;
Security Register2: A23-A16=00H, A15-A8=00100000b, A7-A0= Byte Address;
Security Register3: A23-A16=00H, A15-A8=00110000b, A7-A0= Byte Address;
9. Dummy bits and Wraps Bits
IO0 = (x, x, x, x, x, x, w4, x)
IO1 = (x, x, x, x, x, x, w5, x)
IO2 = (x, x, x, x, x, x, w6, x)
IO3 = (x, x, x, x, x, x, x, x)

10. Address, continuous Read Mode bits, Dummy bits, Manufacture ID and Device ID

IO0 = (A20, A16, A12, A8, A4, A0, M4, M0, x, x, x, x, MID4, MID0, DID4, DID0)

IO1 = (A21, A17, A13, A9, A5, A1, M5, M1, x, x, x, x, MID5, MID1, DID5, DID1)

IO2 = (A22, A18, A14, A10, A6, A2, M6, M2, x, x, x, x, MID6, MID2, DID6, DID2)

IO3 = (A23, A19, A15, A11, A7, A3, M7, M3, x, x, x, x, MID7, MID3, DID7, DID3)

Security Register 0 can be used to store the Flash Discoverable Parameters,
The feature is upon special order, please contact Boya Microelectronics for details.

7.1 Configuration and Status Instructions

7.1.1 Write Enable (06H)

See [Figure 5](#), the Write Enable instruction is for setting the Write Enable Latch bit. The Write Enable Latch bit must be set prior to every Page Program, Sector Erase, Block Erase, Chip Erase, Write Status Register instruction and Erase/Program Security Registers instruction. The Write Enable instruction sequence: /CS goes low sending the Write Enable instruction /CS goes high.

Figure 5. Write Enable Sequence Diagram

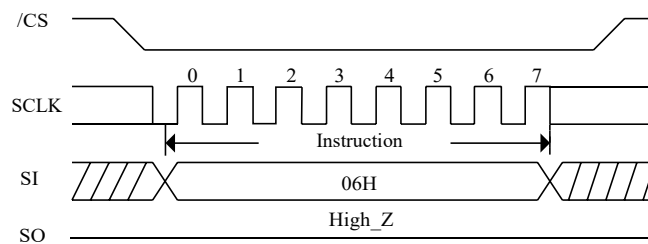

7.1.2 Write Disable (04H)

See [Figure 6](#), the Write Disable instruction is for resetting the Write Enable Latch bit. The Write Disable instruction sequence: /CS goes low -> sending the Write Disable instruction -> /CS goes high. The WEL bit is reset by following condition: Power-up and upon completion of the Write Status Register, Page Program, Sector Erase, Block Erase and Chip Erase, Erase/Program Security Registers and Reset instructions.

Figure 6. Write Disable Sequence Diagram

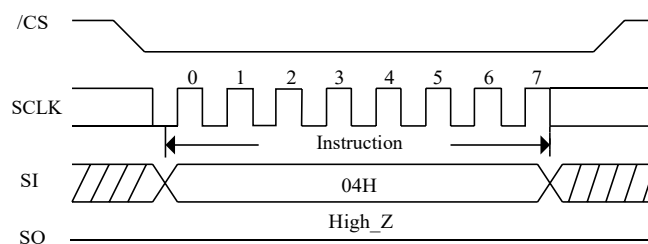

7.1.3 Read Status Register (05H or 35H or 15H)

See [Figure 7](#) the Read Status Register (RDSR) instruction is for reading the Status Register. The Status Register may be read at any time, even while a Program, Erase or Write Status Register cycle is in progress. When one of these cycles is in progress, it is recommended to check the Write in Progress (WIP) bit before sending a new instruction to the device. It is also possible to read the Status Register continuously. For instruction code “05H”, the SO will output Status Register bits S7~S0. The instruction code “35H”, the SO will output Status Register bits S15~S8, The instruction code “15H”, the SO will output Status Register bits S23~16.

Figure 7. Read Status Register Sequence Diagram

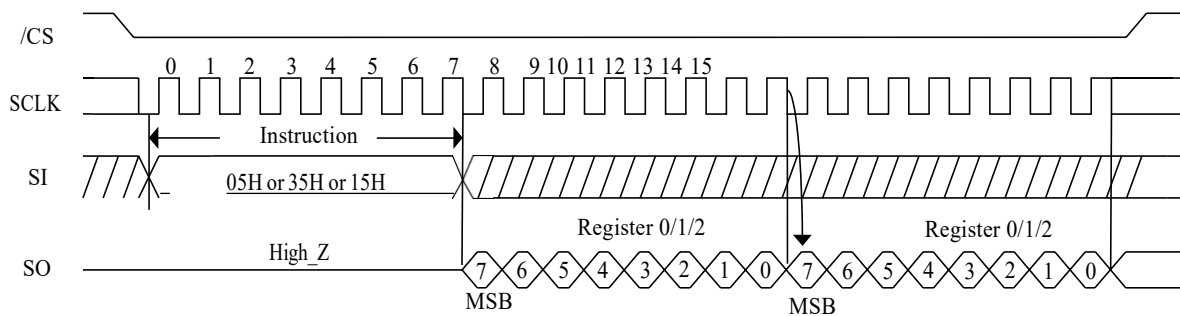

7.1.4 Write Status Register (01H or 31H or 11H)

See [Figure 8](#), the Write Status Register instruction allows new values to be written to the Status Register. Before it can be accepted, a Write Enable instruction must previously have been executed. After the Write Enable instruction has been decoded and executed, the device sets the Write Enable Latch (WEL).

The Write Status Register instruction has no effect on S23, S20, S19, S18, S17, S16, S15, S1 and S0 of the Status Register. /CS must be driven high after the eighth bit of the data byte has been latched in. If not, the Write Status Register instruction is not executed. As soon as /CS is driven high, the self-timed Write Status Register cycle (whose duration is t_w) is initiated. While the Write Status Register cycle is in progress, the Status Register may still be read to check the value of the Write in Progress (WIP) bit. The Write in Progress (WIP) bit is 1 during the self-timed Write Status Register cycle, and is 0 when it is completed. When the cycle is completed, the Write Enable Latch is reset.

The Write Status Register instruction allows the user to change the values of the Block Protect (BP4, BP3, BP2, BP1, BP0) bits, to define the size of the area that is to be treated as read-only, as defined in [Table 3](#). The Write Status Register instruction also allows the user to set or reset the Status Register Protect (SRP1 and SRP0) bits in accordance with the Write Protect (/WP) signal. The Status Register Protect (SRP1 and SRP0) bits and Write Protect (/WP) signal allow the device to be put in the Hardware Protected Mode. The Write Status Register instruction is not executed once the Hardware Protected Mode is entered.

Figure 8. Write Status Register Sequence Diagram

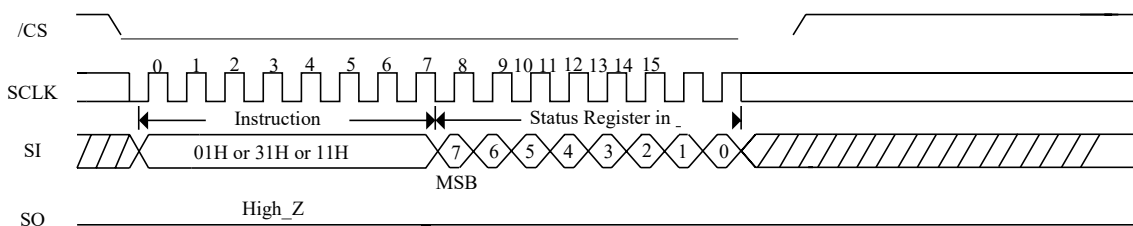

7.1.5 Write Enable for Volatile Status Register (50H)

See [Figure 9](#), the non-volatile Status Register bits can also be written to as volatile bits. This gives more flexibility to change the system configuration and memory protection schemes quickly without waiting for the typical non-volatile bit write cycles or affecting the endurance of the Status Register non-volatile bits. Write Enable for Volatile Status Register instruction will not set the Write Enable Latch bit, it is only valid for the Write Status Registers instruction to change the volatile Status Register bit values.

Figure 9. Write Enable for Volatile Status Register

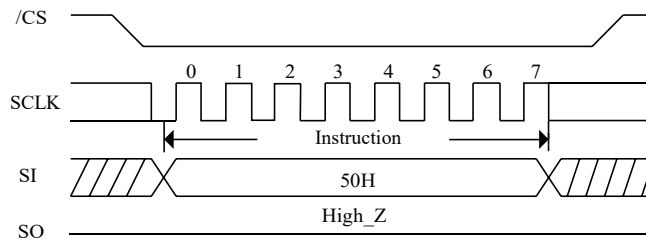

7.2 Read Instructions

7.2.1 Read Data (03H)

See [Figure 10](#), the Read Data Bytes (READ) instruction is followed by a 3-byte address (A23-A0), each bit being latched-in during the rising edge of SCLK. Then the memory content, at that address, is shifted out on SO, each bit being shifted out, at a Max frequency f_R, during the falling edge of SCLK. The address is automatically incremented to the next higher address after each byte of data is shifted out allowing for a continuous stream of data. This means that the entire memory can be accessed with a single command as long as the clock continues. The command is completed by driving /CS high. The whole memory can be read with a single Read Data Bytes (READ) instruction. Any Read Data Bytes (READ) instruction, while an Erase, Program or Write cycle is in progress, is rejected without having any effects on the cycle that is in progress.

Figure 10. Read Data Bytes Sequence Diagram

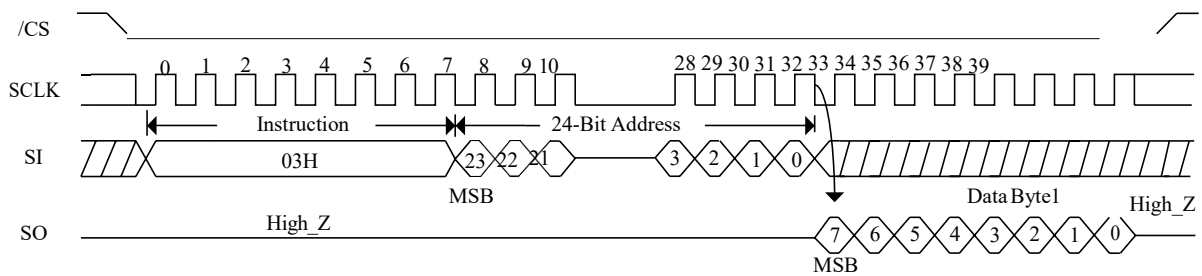

7.2.2 Fast Read (0BH)

See [Figure 11](#), the Read Data Bytes at Higher Speed (Fast Read) instruction is for quickly reading data out. It is followed by a 3-byte address (A23-A0) and a dummy byte, each bit being latched-in during the rising edge of SCLK. Then the memory content, at that address, is shifted out on SO, each bit being shifted out, at a Max frequency f_c , during the falling edge of SCLK. The first byte addressed can be at any location. The address is automatically incremented to the next higher address after each byte of data is shifted out.

Figure 11. Fast Read Sequence Diagram

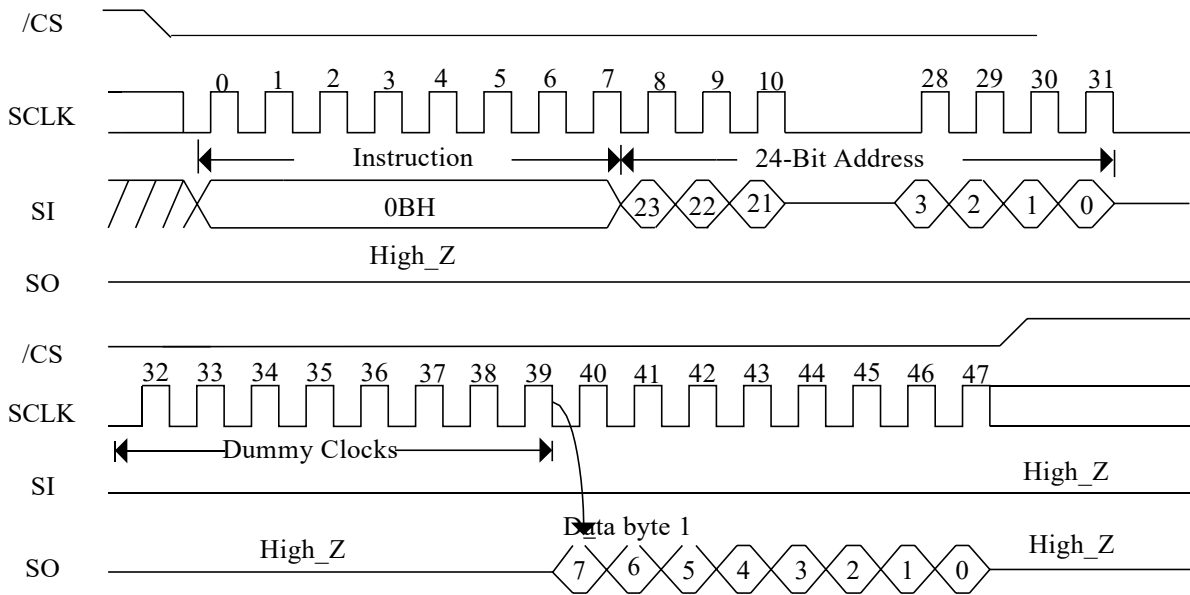

7.2.3 Dual Output Fast Read (3BH)

See [Figure 12](#), the Dual Output Fast Read instruction is followed by 3-byte address (A23-A0) and a dummy byte, each bit being latched in during the rising edge of SCLK, then the memory contents are shifted out 2-bit per clock cycle from SI and SO. The first byte addressed can be at any location. The address is automatically incremented to the next higher address after each byte of data is shifted out.

Figure 12. Dual Output Fast Read Sequence Diagram

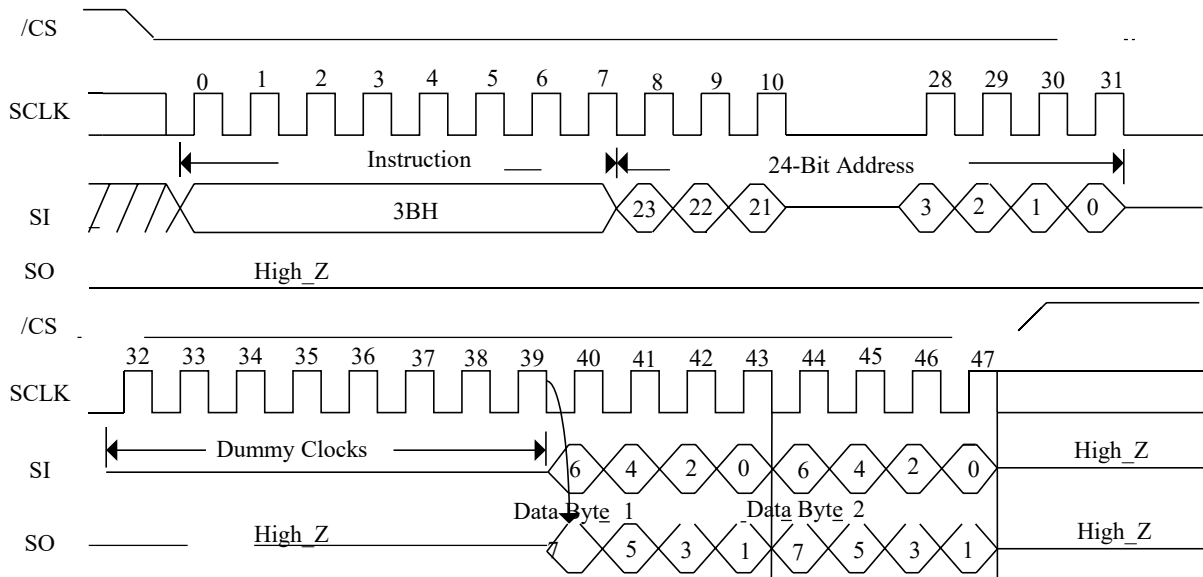

7.2.4 Quad Output Fast Read (6BH)

See [Figure 13](#), the Quad Output Fast Read instruction is followed by 3-byte address (A23-A0) and a dummy byte, each bit being latched in during the rising edge of SCLK, then the memory contents are shifted out 4-bit per clock cycle from IO3, IO2, IO1 and IO0. The first byte addressed can be at any location. The address is automatically incremented to the next higher address after each byte of data is shifted out.

Figure 13. Quad Output Fast Read Sequence Diagram

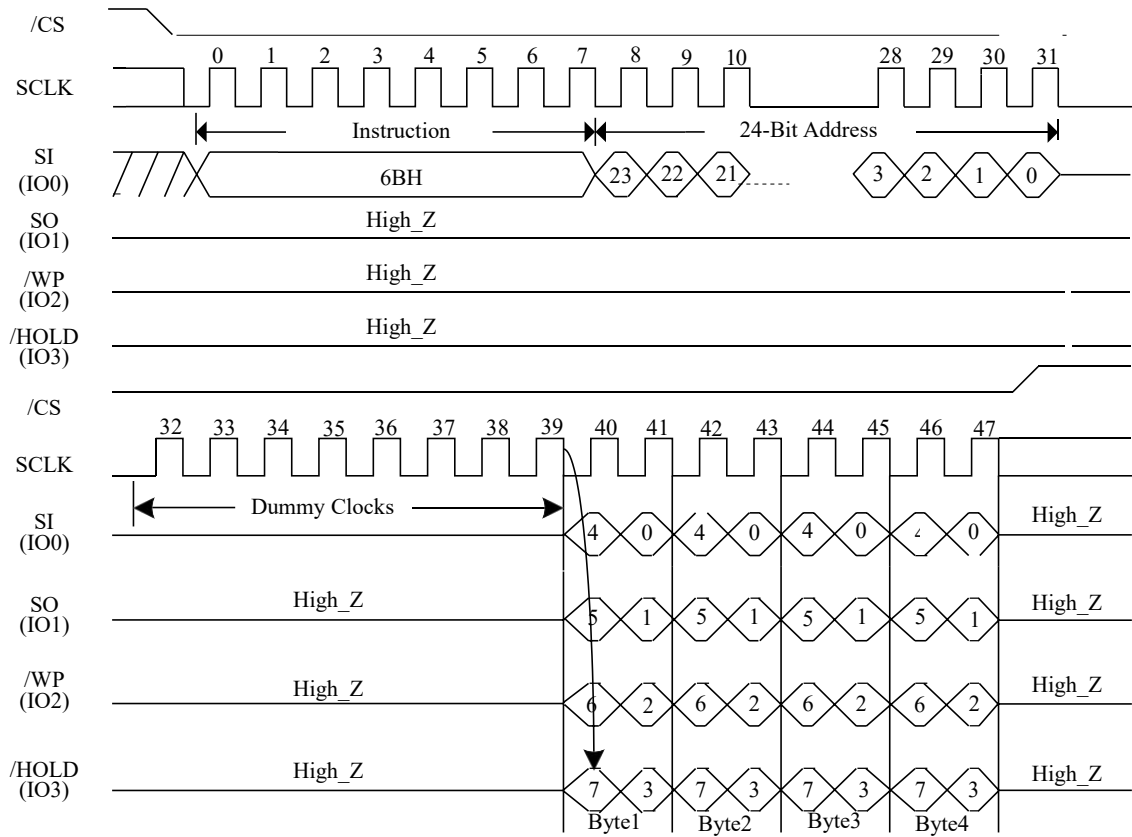

7.2.5 Dual I/O Fast Read (BBH)

See [Figure 14](#), the Dual I/O Fast Read instruction is similar to the Dual Output Fast Read instruction but with the capability to input the 3-byte address (A23-0) and a “Continuous Read Mode” byte 2-bit per clock by SI and SO, each bit being latched in during the rising edge of SCLK, then the memory contents are shifted out 2-bit per clock cycle from SI and SO. The first byte addressed can be at any location. The address is automatically incremented to the next higher address after each byte of data is shifted out.

Dual I/O Fast Read with “continuous Read Mode”

The Dual I/O Fast Read instruction can further reduce instruction overhead through setting the “continuous Read Mode” bits (M7-4) after the inputs 3-byte address A23-A0). If the “continuous Read Mode” bits (M5-4)=(1,0), then the next Dual I/O fast Read instruction (after CS/ is raised and then lowered) does not require the BBH instruction code. The instruction sequence is shown in the following [Figure 15](#). If the “continuous Read Mode” bits (M5-4) does not equal (1,0), the next instruction requires the first BBH instruction code, thus returning to normal operation. A “continuous Read Mode” Reset instruction can be used to reset (M5-4) before issuing normal instruction.

Figure 14. Dual I/O Fast Read Sequence Diagram (Initial command or previous (M5-4)≠(1,0))

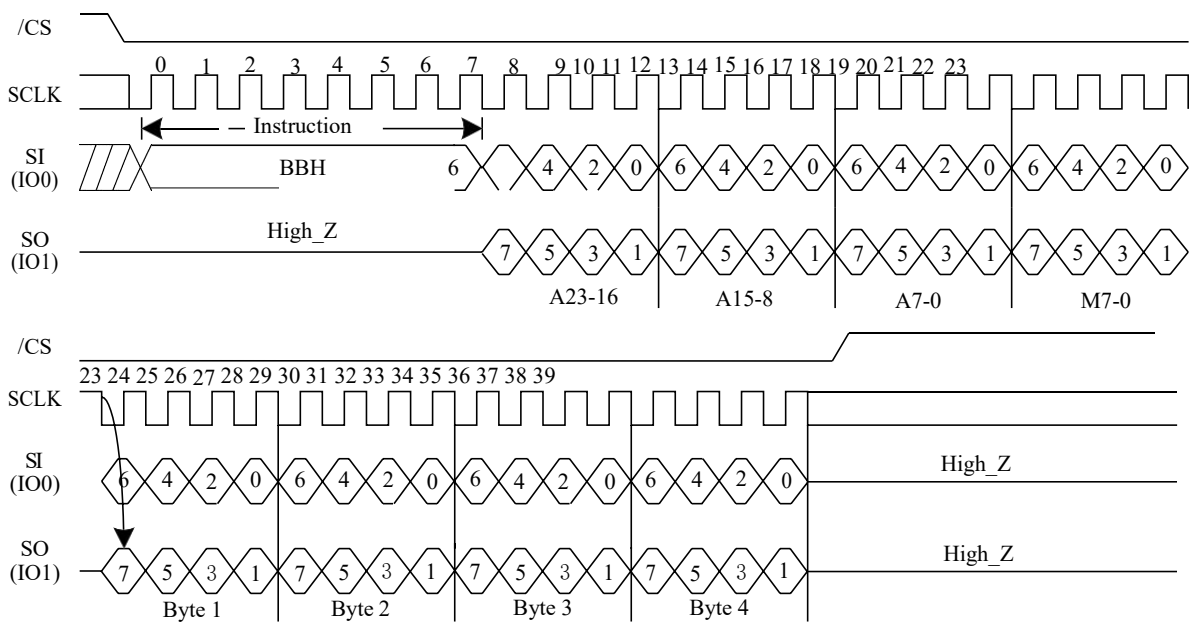
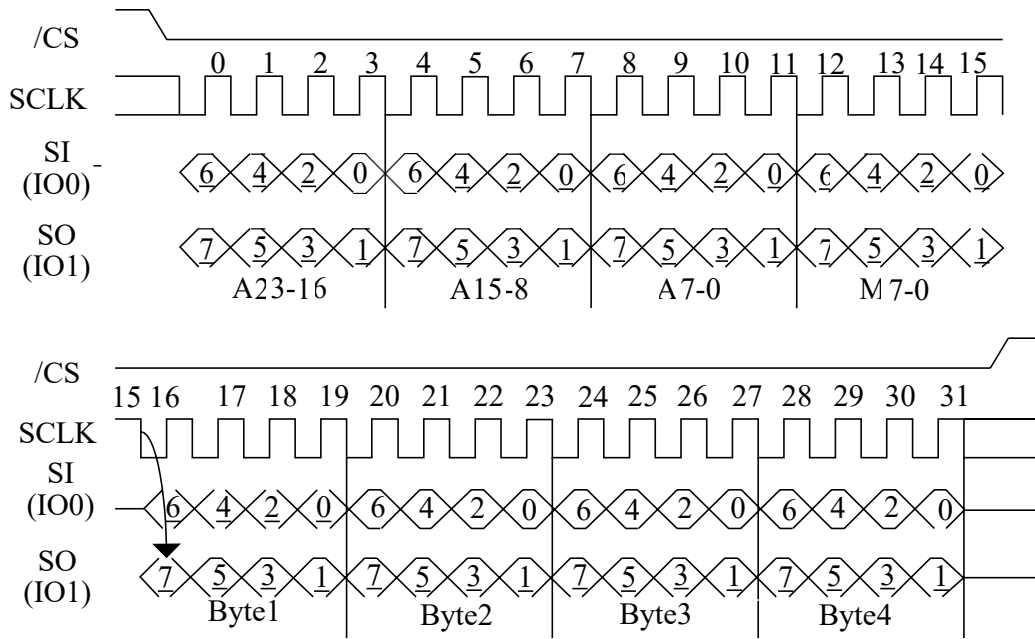

Figure 15. Dual I/O Fast Read Sequence Diagram (Previous command set (M5-4) =(1,0))



7.2.6 Quad I/O Fast Read (EBH)

See [Figure 16](#), the Quad I/O Fast Read instruction is similar to the Dual I/O Fast Read instruction but with the capability to input the 3-byte address (A23-0) and a “Continuous Read Mode” byte and 4-dummy clock 4-bit per clock by IO0, IO1, IO3, IO4, each bit being latched in during the rising edge of SCLK, then the memory contents are shifted out 4-bit per clock cycle from IO0, IO1, IO2, IO3. The first byte addressed can be at any location. The address is automatically incremented to the next higher address after each byte of data is shifted out. The Quad Enable bit (QE) of Status Register must be set to enable for the Quad I/O Fast read instruction.

Quad I/O Fast Read with “Continuous Read Mode”

The Quad I/O Fast Read instruction can further reduce instruction overhead through setting the “Continuous Read Mode” bits (M7-0) after the input Address bits (A23-0), as shown in [Figure 16](#), If the “Continuous Read Mode” bits (M5-4) = (1,0), then the next Fast Read Quad I/O instruction(after /CS is raised and then lowered) does not require the EBH instruction code, The instruction sequence is shown in the followed [Figure 17](#). If the “Continuous Read Mode” bits M5-4 do not equal to (1,0), the next instruction requires the first EBH instruction code, thus returning to normal operation. A “Continuous Read Mode” Reset command can also be used to reset (M5-4) before issuing normal command.

Figure 16. Quad I/O Fast Read Sequence Diagram (Initial command or previous (M5-4 ≠ (1,0)))

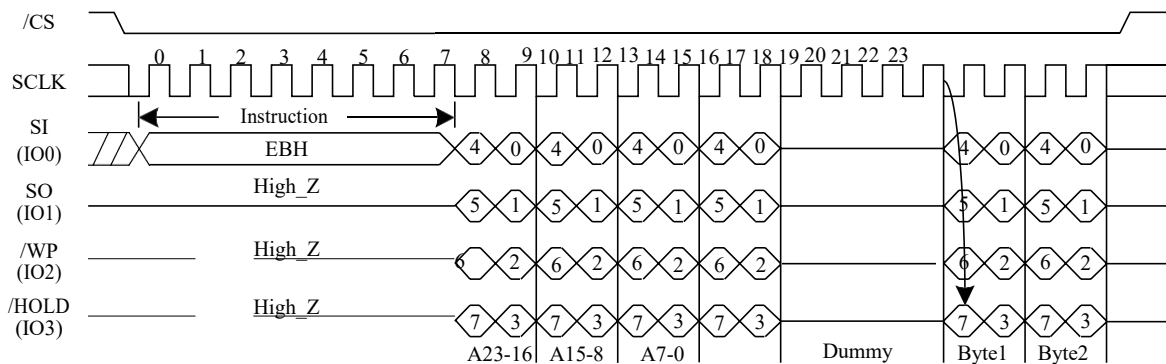
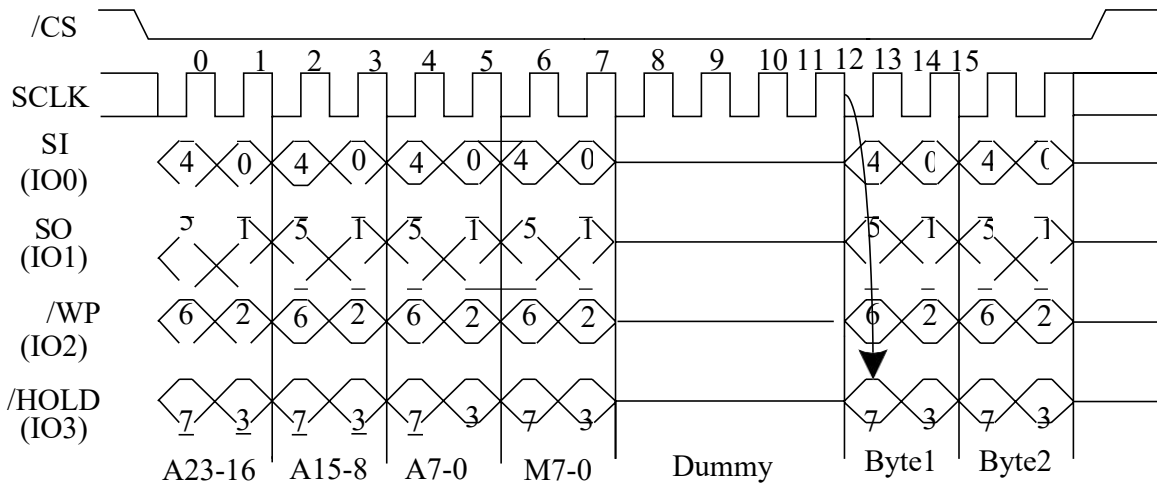

Figure 17. Quad I/O Fast Read Sequence Diagram (Previous command set (M5-4)=(1,0))



Quad I/O Fast Read with “8/16/32/64-Byte Wrap Around”

The Quad I/O Fast Read instruction can also be used to access a specific portion within a page by issuing a “Set Burst with Wrap” (77H) instruction prior to EBH. The “Set Burst with Wrap” (77H) instruction can either enable or disable the “Wrap Around” feature for the following EBH instructions. When “Wrap Around” is enabled, the data being accessed can be limited to either an 8, 16, 32 or 64-byte section of a 256-byte page. The output data starts at the initial address specified in the instruction, once it reaches the ending boundary of the 8/16/32/64-byte section, the output will wrap around to the beginning boundary automatically until $\overline{\text{CS}}$ is pulled high to terminate the instruction.

The Burst with Wrap feature allows applications that use cache to quickly fetch a critical address and then fill the cache afterwards within a fixed length (8/16/32/64-byte) of data without issuing multiple read instructions.

The “Set Burst with Wrap” instruction allows three “Wrap Bits”, W6-4 to be set. The W4 bit is used to enable or disable the “Wrap Around” operation while W6-5 are used to specify the length of the wrap around section within a page.

7.2.7 Quad I/O Word Fast Read (E7H)

The Quad I/O Word Fast Read instruction is similar to the Quad Fast Read instruction except that the lowest address bit (A0) must equal 0 and 2-dummy clock. The instruction sequence is shown in the followed *Figure 18*, the first byte addressed can be at any location. The address is automatically incremented to the next higher address after each byte of data is shifted out. The Quad Enable bit (QE) of Status Register (S9) must be set to enable for the Quad I/O Word Fast Read instruction.

Quad I/O Word Fast Read with “Continuous Read Mode”

The Quad I/O Word Fast Read instruction can further reduce instruction overhead through setting the “Continuous Read Mode” bits (M7-0) after the input 3-byte Address bits (A23-0). If the “Continuous Read Mode” bits (M5-4) = (1, 0), then the next Quad I/O Fast Read instruction (after /CS is raised and then lowered) does not require the E7H instruction code, the instruction sequence is shown in the followed *Figure 19*. If the “Continuous Read Mode” bits M5-4 do not equal to (1,0), the next instruction requires the first E7H instruction code, thus returning to normal operation. A “Continuous Read Mode” Reset command can also be used to reset (M5-4) before issuing normal command.

Figure 18. Quad I/O Word Fast Read Sequence Diagram (Initial command or previous (M5-4) ≠ (1,0))

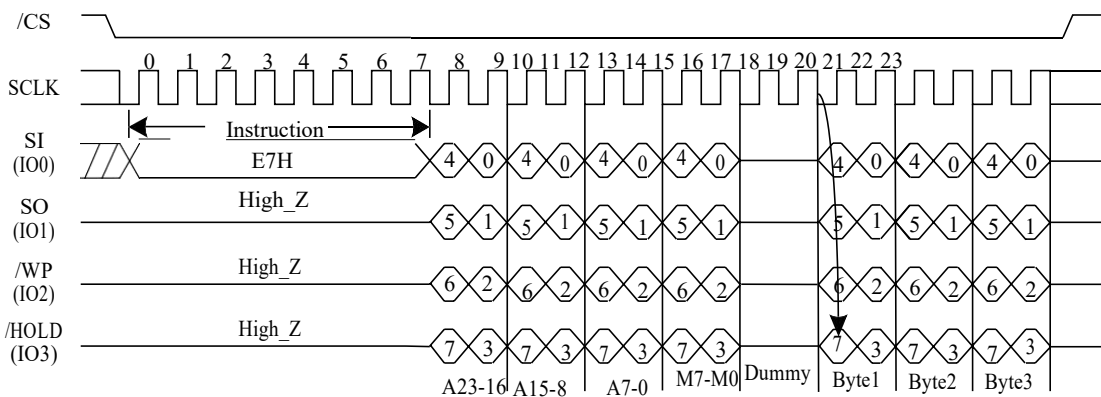
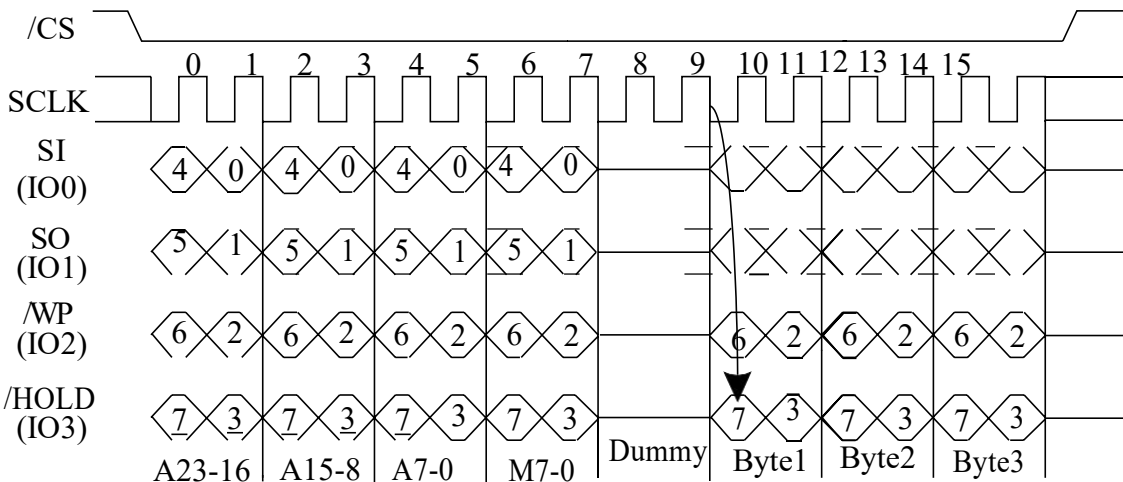

Figure 19. Quad I/O word Fast Read Sequence Diagram (Previous command set (M5-4) = (1,0))



Quad I/O Word Fast Read with “8/16/32/64-Byte Wrap Around” in standard SPI mode

The Quad I/O Fast Read instruction can also be used to access a specific portion within a page by issuing a “Set Burst with Wrap” (77H) instruction prior to E7H. The “Set Burst with Wrap” (77H) instruction can either enable or disable the “Wrap Around” feature for the following E7H instructions. When “Wrap Around” is enabled, the data being accessed can be limited to either an 8, 16, 32 or 64-byte section of a 256-byte page. The output data starts at the initial address specified in the instruction, once it reaches the ending boundary of the 8/16/32/64-byte section, the output will wrap around to the beginning boundary automatically until /CS is pulled high to terminate the instruction.

The Burst with Wrap feature allows applications that use cache to quickly fetch a critical address and then fill the cache afterwards within a fixed length (8/16/32/64-byte) of data without issuing multiple read instructions.

The “Set Burst with Wrap” instruction allows three “Wrap Bits”, W6-4 to be set. The W4 bit is used to enable or disable the “Wrap Around” operation while W6-5 are used to specify the length of the wrap around section within a page.

7.2.8 Set Burst with Wrap (77H)

See [Figure 20](#), The Set Burst with Wrap instruction is used in conjunction with "Quad I/O Fast Read" and "Quad I/O Word Fast Read" instruction to access a fixed length of 8/16/32/64-byte section within a 256-byte page, in standard SPI mode.

The Set Burst with Wrap instruction sequence: /CS goes low -> Send Set Burst with Wrap instruction -> Send 24 Dummy bits -> Send 8 bits "Wrap bits" -> /CS goes high.

If W6-4 is set by a Set Burst with Wrap instruction, all the following "Fast Read Quad I/O" and "Word Read Quad I/O" instructions will use the W6-4 setting to access the 8/16/32/64-byte section within any page. To exit the "Wrap Around" function and return to normal read operation, another Set Burst with Wrap instruction should be issued to set W4=1. The default value of W4 upon power on is 1.

W6 , W5	W4 = 0		W4 =1 (DEFAULT)	
	Wrap Around	Wrap Length	Wrap Around	Wrap Length
0 0	Yes	8-byte	No	N/A
0 1	Yes	16-byte	No	N/A
1 0	Yes	32-byte	No	N/A
1 1	Yes	64-byte	No	N/A

Figure 20. Set Burst with Wrap Sequence Diagram

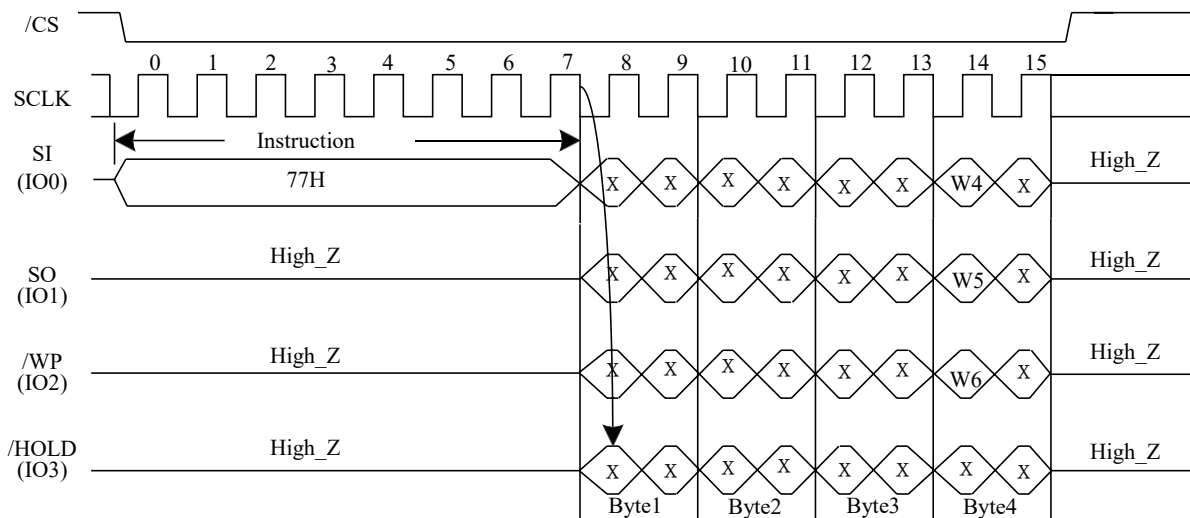

7.3 ID and Security Instructions

7.3.1 Read Manufacture ID/ Device ID (90H)

See [Figure 21](#), The Read Manufacturer/Device ID instruction is an alternative to the Release from Power-Down/Device ID instruction that provides both the JEDEC assigned Manufacturer ID and the specific Device ID.

The instruction is initiated by driving the /CS pin low and shifting the instruction code “90H” followed by a 24-bit address (A23-A0) of 000000H. If the 24-bit address is initially set to 000001H, the Device ID will be read first.

Figure 21. Read Manufacture ID/ Device ID Sequence Diagram

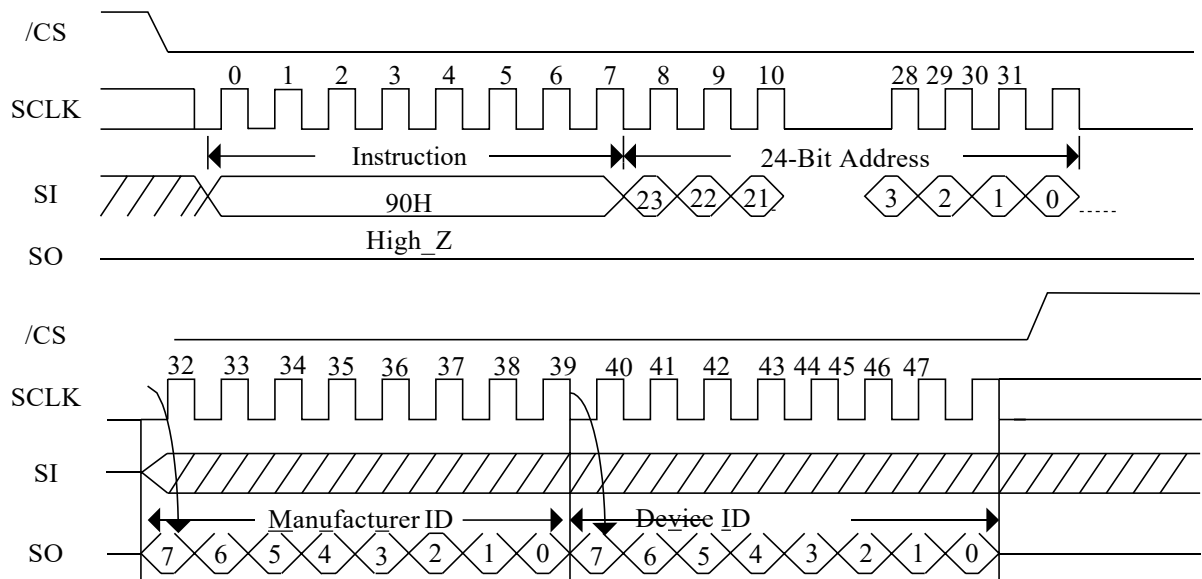

7.3.2 Dual I/O Read Manufacture ID/ Device ID (92H)

See [Figure 22](#), the Dual I/O Read Manufacturer/Device ID instruction is an alternative to the Release from Power-Down/Device ID instruction that provides both the JEDEC assigned Manufacturer ID and the specific Device ID by Dual I/O.

The instruction is initiated by driving the /CS pin low and shifting the instruction code “92H” followed by a 24-bit address (A23-A0) of 000000H. If the 24-bit address is initially set to 000001H, the Device ID will be read first.

Figure 22. Dual I/O Read Manufacture ID/ Device ID Sequence Diagram

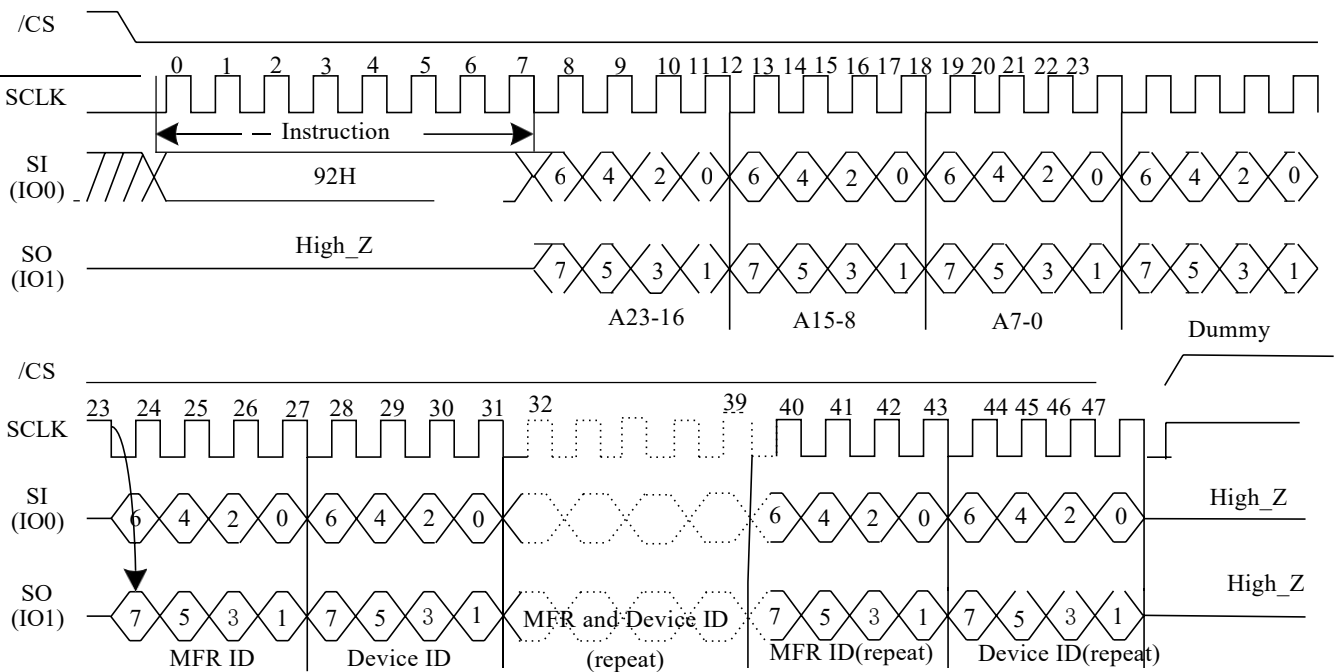

7.3.3 Quad I/O Read Manufacture ID/ Device ID (94H)

See [Figure 23](#), the Quad I/O Read Manufacturer/Device ID instruction is an alternative to the Release from Power-Down/Device ID instruction that provides both the JEDEC assigned Manufacturer ID and the specific Device ID by quad I/O.

The instruction is initiated by driving the /CS pin low and shifting the instruction code “94H” followed by a 24-bit address (A23-A0) of 000000H and 4 dummy clocks. If the 24-bit address is initially set to 000001H, the Device ID will be read first.

Figure 23. Quad I/O Read Manufacture ID/ Device ID Sequence Diagram

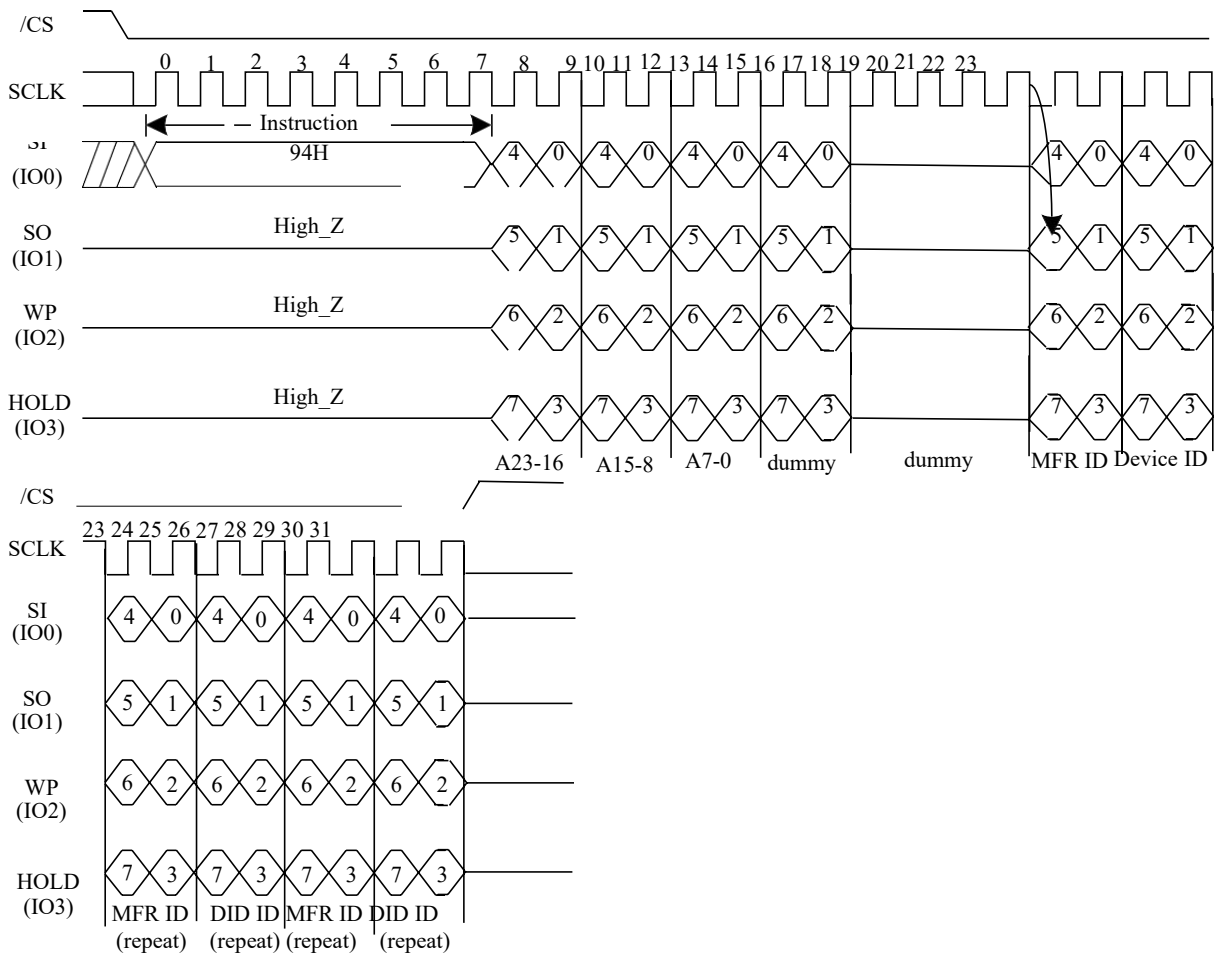

7.3.4 Read JEDEC ID (9FH)

The JEDEC ID instruction allows the 8-bit manufacturer identification to be read, followed by two bytes of device identification. The device identification indicates the memory type in the first byte, and the memory capacity of the device in the second byte. JEDEC ID instruction while an Erase or Program cycle is in progress, is not decoded, and has no effect on the cycle that is in progress. The JEDEC ID instruction should not be issued while the device is in Deep Power-Down Mode.

See [Figure 24](#), The device is first selected by driving /CS to low. Then, the 8-bit instruction code for the instruction is shifted in. This is followed by the 24-bit device identification, stored in the memory, being shifted out on Serial Data Output, each bit being shifted out during the falling edge of Serial Clock. The JEDEC ID instruction is terminated by driving /CS to high at any time during data output. When /CS is driven high, the device is put in the Standby Mode. Once in the Standby Mode, the device waits to be selected, so that it can receive, decode and execute instructions.

Figure 24. JEDEC ID Sequence Diagram

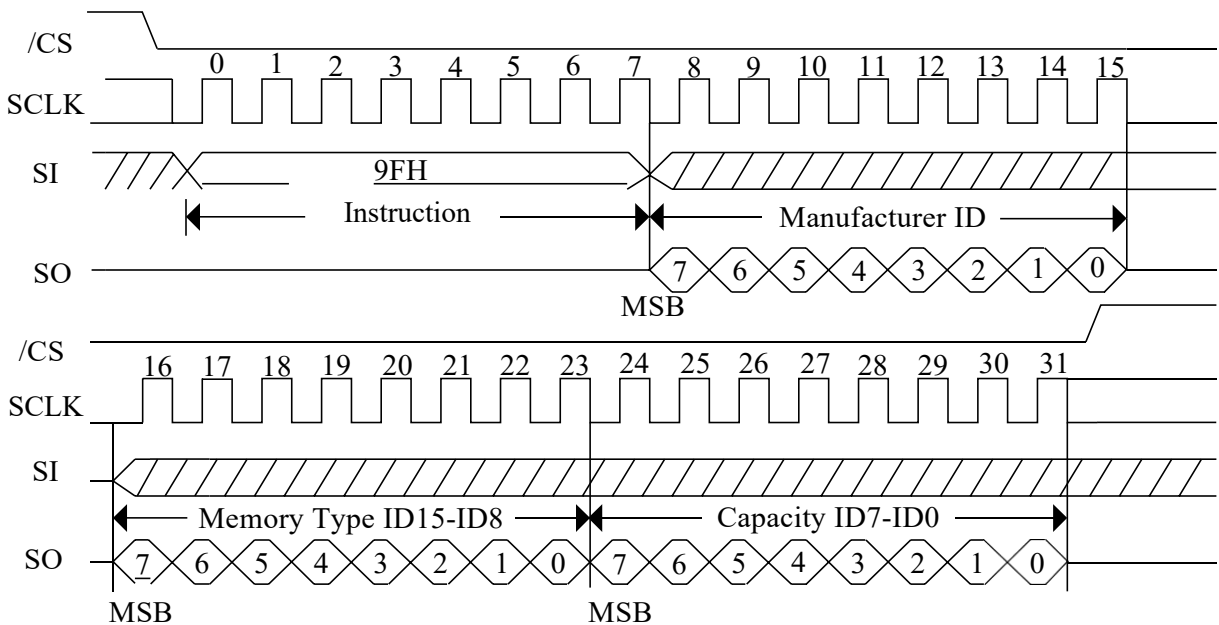

7.3.5 Read Unique ID Number (4Bh)

The Read Unique ID Number instruction accesses a factory-set read-only 64-bit number that is unique to each BY25Q64 device. The ID number can be used in conjunction with user software methods to help prevent copying or cloning of a system. The Read Unique ID instruction is initiated by driving the /CS pin low and shifting the instruction code “4Bh” followed by a four bytes of dummy clocks. After which, the 64-bit ID is shifted out on the falling edge of SCLK as shown in [Figure 25](#).

Figure 25. Read Unique ID Sequence Diagram

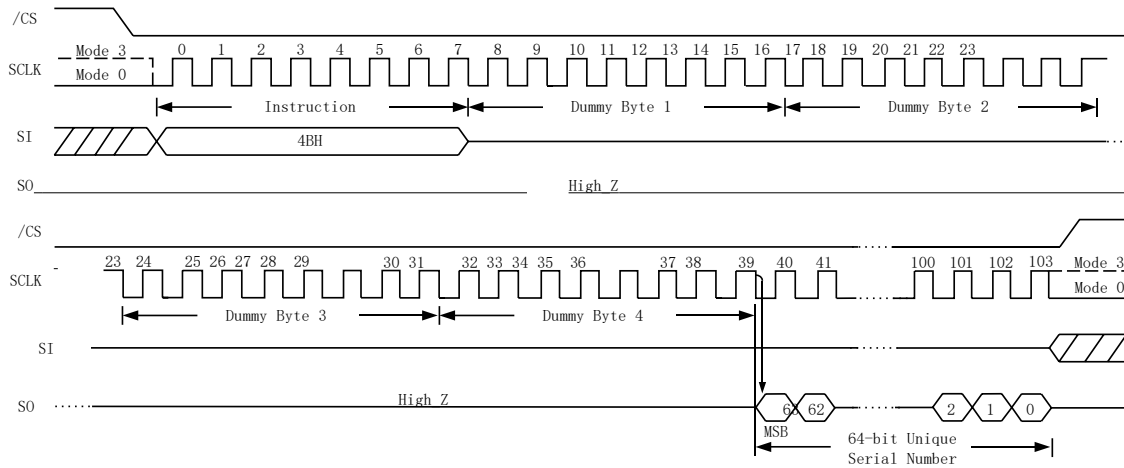

7.3.6 Deep Power-Down (B9H)

Although the standby current during normal operation is relatively low, standby current can be further reduced with the Deep Power-down instruction. The lower power consumption makes the Deep Power-down (DPD) instruction especially useful for battery powered applications (see ICC1 and ICC2). The instruction is initiated by driving the /CS pin low and shifting the instruction code “B9h” as shown in Figure 26.

The /CS pin must be driven high after the eighth bit has been latched. If this is not done the Deep Power down instruction will not be executed. After /CS is driven high, the power-down state will entered within the time duration of tDP. While in the power-down state only the Release from Deep Power-down / Device ID instruction, which restores the device to normal operation, will be recognized. All other Instructions are ignored. This includes the Read Status Register instruction, which is always available during normal operation. Ignoring all but one instruction also makes the Power Down state a useful condition for securing maximum write protection. The device always powers-up in the normal operation with the standby current of ICC1.

Figure 26. Deep Power-Down Sequence Diagram

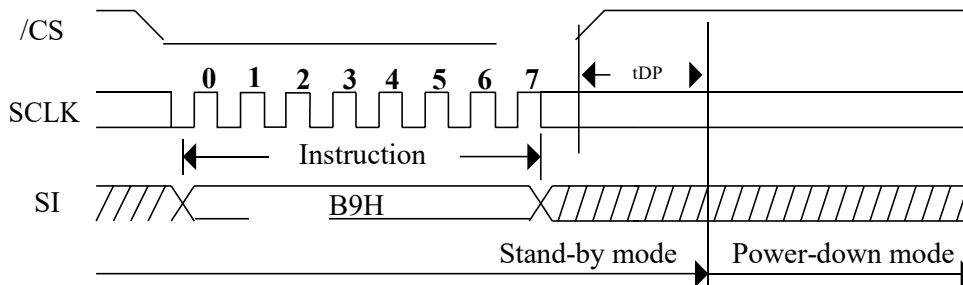

7.3.7 Release from Deep Power-Down/Read Device ID (ABH)

The Release from Power-Down or Device ID instruction is a multi-purpose instruction. It can be used to release the device from the Power-Down state or obtain the devices electronic identification (ID) number.

See [Figure 27](#), to release the device from the Power-Down state, the instruction is issued by driving the /CS pin low, shifting the instruction code “ABH” and driving /CS high. Release from Power-Down will take the time duration of tRES1 (See [AC Characteristics](#)) before the device will resume normal operation and other instruction are accepted. The /CS pin must remain high during the tRES1 time duration.

When used only to obtain the Device ID while not in the Power-Down state, the instruction is initiated by driving the /CS pin low and shifting the instruction code “ABH” followed by 3-dummy byte. The Device ID bits are then shifted out on the falling edge of SCLK with most significant bit (MSB) first as shown in [Figure 28](#). The Device ID value for the BY25Q64AS is listed in Manufacturer and Device Identification table. The Device ID can be read continuously. The instruction is completed by driving /CS high.

When used to release the device from the Power-Down state and obtain the Device ID, the instruction is the same as previously described, and shown in [Figure 28](#), except that after /CS is driven high it must remain high for a time duration of tRES2 (See [AC Characteristics](#)). After this time duration the device will resume normal operation and other instruction will be accepted. If the Release from Power-Down/Device ID instruction is issued while an Erase, Program or Write cycle is in process (when WIP equal 1) the instruction is ignored and will not have any effects on the current cycle.

Figure 27. Release Power-Down Sequence Diagram

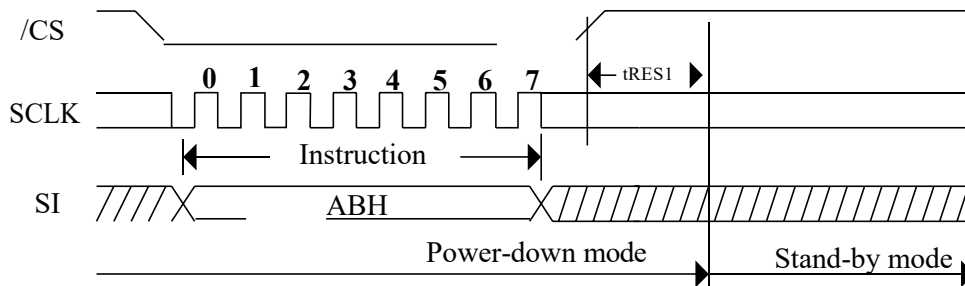
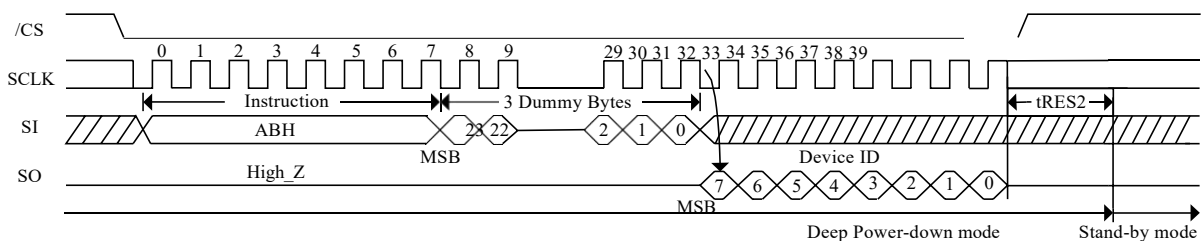

Figure 28. Release Power-Down/Read Device ID Sequence Diagram



7.3.8 Read Security Registers (48H)

See [Figure 29](#), the Read Security Registers instruction is similar to Fast Read instruction. The instruction is followed by a 3-byte address (A23-A0) and a dummy byte, each bit being latched-in during the rising edge of SCLK. Then the memory content, at that address, is shifted out on SO, each bit being shifted out, at a Max frequency fC, during the falling edge of SCLK. The first byte addressed can be at any location. The address is automatically incremented to the next higher address after each byte of data is shifted out. Once the A7-A0 address reaches the last byte of the register (Byte FFH), it will reset to 000H, the instruction is completed by driving /CS high.

Address	A23-A16	A15-A12	A11-A8	A7-A0
Security Registers 1	00H	0001	0000	Byte Address
Security Registers 2	00H	0010	0000	Byte Address
Security Registers 3	00H	0011	0000	Byte Address

Figure 29. Read Security Registers instruction Sequence Diagram

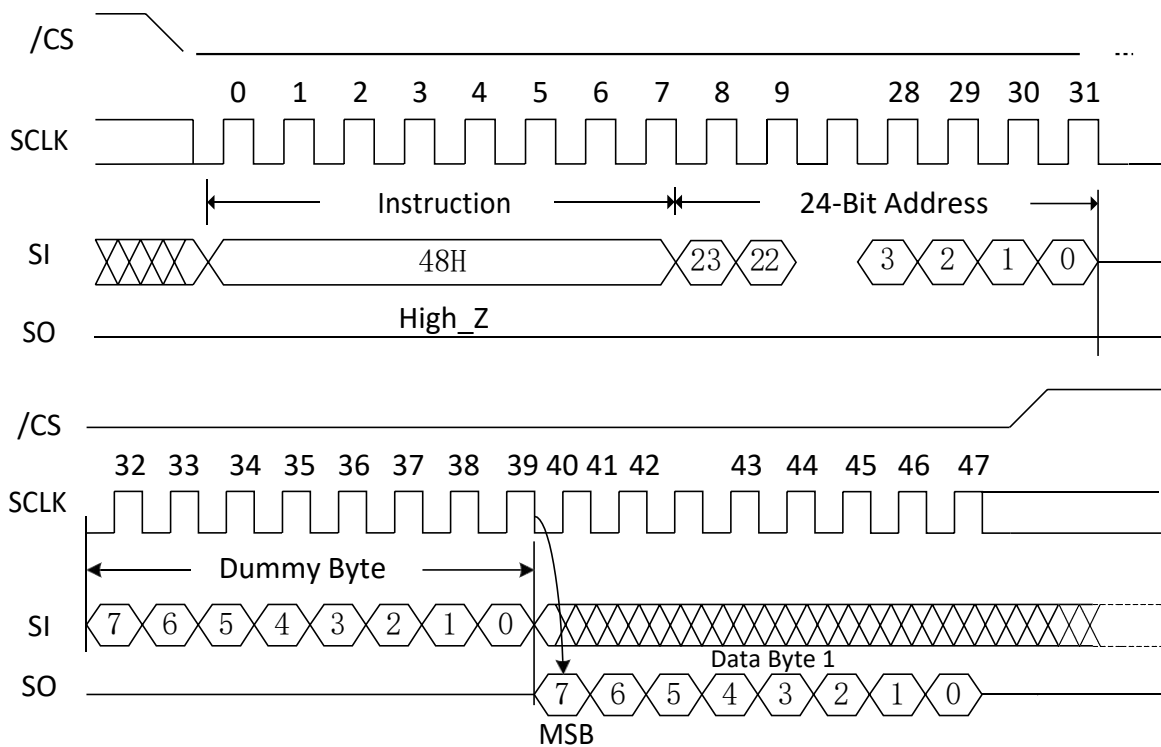

7.3.9 Erase Security Registers (44H)

The BY25Q64AS provides three 256-byte Security Registers which can be erased and programmed individually. These registers may be used by the system manufacturers to store security and other important information separately from the main memory array.

See [Figure 30](#), the Erase Security Registers instruction is similar to Sector/Block Erase instruction. A Write Enable instruction must previously have been executed to set the Write Enable Latch bit.

The Erase Security Registers instruction sequence: /CS goes low sending Erase Security Registers instruction /CS goes high. /CS must be driven high after the eighth bit of the instruction code has been latched in otherwise the Erase Security Registers instruction is not executed. As soon as /CS is driven high, the self-timed Erase Security Registers cycle (whose duration is tSE) is initiated. While the Erase Security Registers cycle is in progress, the Status Register may be read to check the value of the Write In Progress (WIP) bit. The Write In Progress (WIP) bit is 1 during the self-timed Erase Security Registers cycle, and is 0 when it is completed. At some unspecified time before the cycle is completed, the Write Enable Latch bit is reset. The Security Registers Lock Bit (LB) in the Status Register can be used to OTP protect the security registers. Once the LB bit is set to 1, the Security Registers will be permanently locked; the Erase Security Registers instruction will be ignored.

Address	A23-A16	A15-A12	A11-A8	A7-A0
Security Registers 1	00H	0001	0000	Byte Address
Security Registers 2	00H	0010	0000	Byte Address
Security Registers 3	00H	0011	0000	Byte Address

Figure 30. Erase Security Registers instruction Sequence Diagram

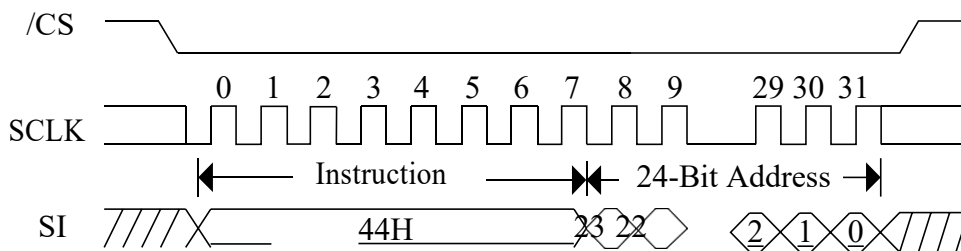

7.3.10 Program Security Registers (42H)

See [Figure 31](#), the Program Security Registers instruction is similar to the Page Program instruction. It allows from 1 to 256 bytes Security Registers data to be programmed. A Write Enable instruction must previously have been executed to set the Write Enable Latch bit before sending the Program Security Registers instruction. The Program Security Registers instruction is entered by driving /CS Low, followed by the instruction code (42H), 3-byte address and at least one data byte on SI. As soon as /CS is driven high, the self-timed Program Security Registers cycle (whose duration is tPP) is initiated. While the Program Security Registers cycle is in progress, the Status Register may be read to check the value of the Write In Progress (WIP) bit. The Write In Progress (WIP) bit is 1 during the self-timed Program Security Registers cycle, and is 0 when it is completed. At some unspecified time before the cycle is completed, the Write Enable Latch bit is reset.

If the Security Registers Lock Bit (LB3/LB2/LB1) is set to 1, the Security Registers will be permanently locked. Program Security Registers instruction will be ignored.

Address	A23-A16	A15-A12	A11-A8	A7-A0
Security Registers 1	00H	0001	0000	Byte Address
Security Registers 2	00H	0010	0000	Byte Address
Security Registers 3	00H	0011	0000	Byte Address

Figure 31. Program Security Registers instruction Sequence Diagram

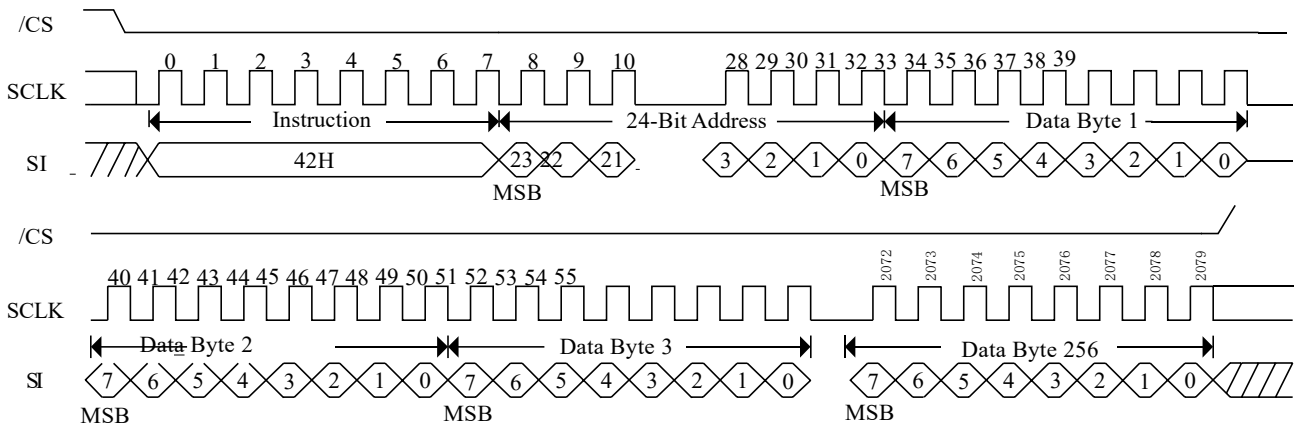

7.3.11 Enable Reset (66H) and Reset Device (99H)

Because of the small package and the limitation on the number of pins, the BY25Q64AS provides a software Reset instruction instead of a dedicated RESET pin. Once the software Reset instruction is accepted, any on-going internal operations will be terminated and the device will return to its default power-on state and lose all the current volatile settings, such as Volatile Status Register bits, Write Enable Latch (WEL) status, Program/Erase Suspend status, Continuous Read Mode bit setting (M7-M0) and Wrap Bit setting (W6-W4).

To avoid accidental reset, both “Enable Reset (66h)” and “Reset (99h)” instructions must be issued in sequence. Any other commands other than “Reset (99h)” after the “Enable Reset (66h)” command will disable the “Reset Enable” state. A new sequence of “Enable Reset (66h)” and “Reset (99h)” is needed to reset the device. Once the Reset command is accepted by the device, the device will take approximately 30us to reset. During this period, no command will be accepted.

The Enable Reset (66h) and Reset (99h) instruction sequence is shown in [Figure 32](#).

Data corruption may happen if there is an on-going or suspended internal Erase or Program operation when Reset command sequence is accepted by the device. It is recommended to check the BUSY bit and the SUS bit in Status Register before issuing the Reset command sequence.

Figure 32. Enable Reset (66h) and Reset (99h) Command Sequence

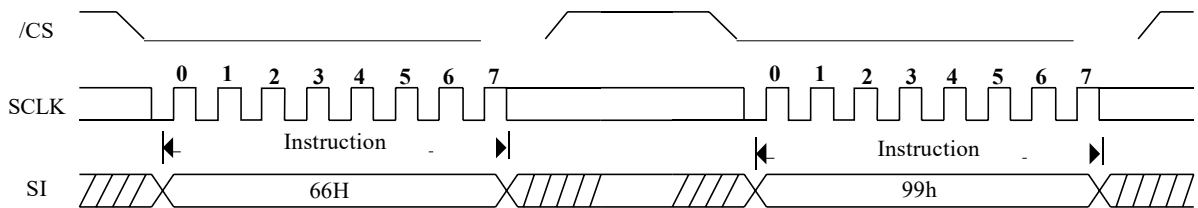

7.3.12 Read Serial Flash Discoverable Parameter (5AH)

See [Figure 33](#), The Serial Flash Discoverable Parameter (SFDP) standard provides a consistent method of describing the functional and feature capabilities of serial flash devices in a standard set of internal parameter tables. These parameter tables can be interrogated by host system software to enable adjustments needed to accommodate divergent features from multiple vendors. The concept is similar to the one found in the Introduction of JEDEC Standard, JESD68 on CFI. SFDP is a standard of JEDEC Standard No.216.

Figure 33. Read Serial Flash Discoverable Parameter command Sequence Diagram

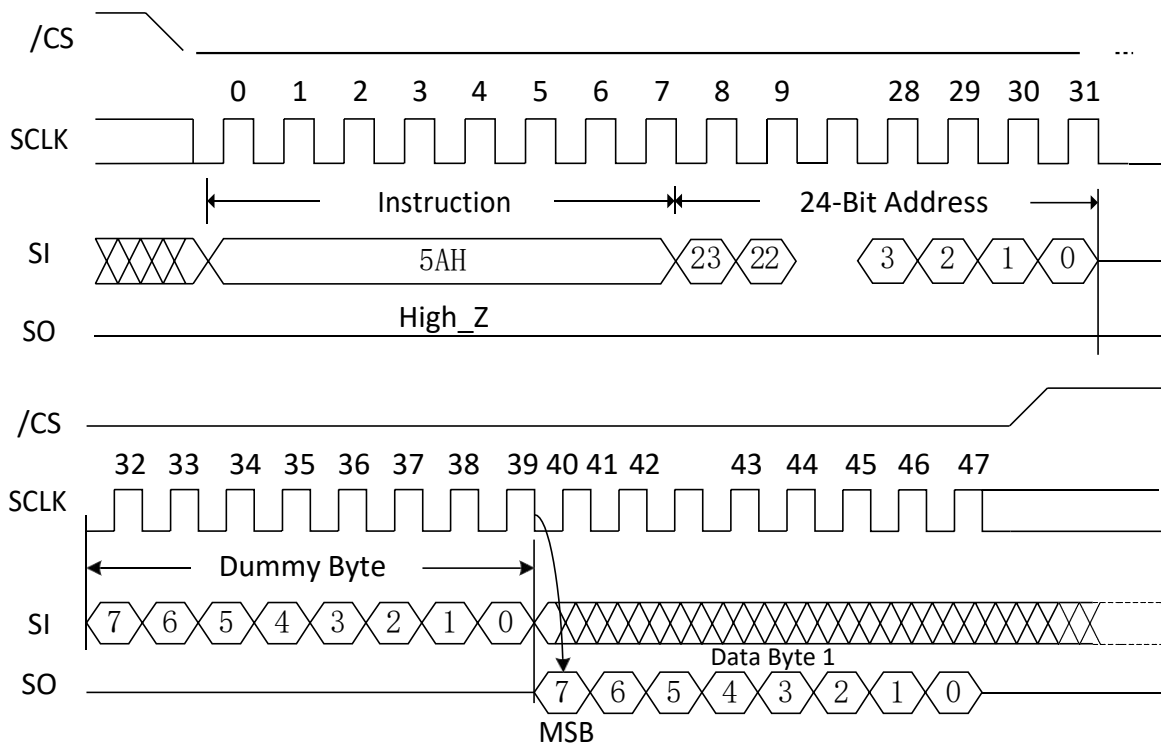

7.4 Program and Erase Instructions

7.4.1 Page Program (02H)

The Page Program instruction is for programming the memory. A Write Enable instruction must previously have been executed to set the Write Enable Latch bit before sending the Page Program instruction.

See [Figure 34](#), the Page Program instruction is entered by driving /CS Low, followed by the instruction code, 3-byte address and at least one data byte on SI. If the 8 least significant address bits (A7-A0) are not all zero, all transmitted data that goes beyond the end of the current page are programmed from the start address of the same page (from the address whose 8 least significant bits (A7-A0) are all zero). /CS must be driven low for the entire duration of the sequence. The Page Program instruction sequence: /CS goes low-> sending Page Program instruction ->3-byte address on SI ->at least 1 byte data on SI-> /CS goes high.

If more than 256 bytes are sent to the device, previously latched data are discarded and the last 256 data bytes are guaranteed to be programmed correctly within the same page. If less than 256 data bytes are sent to device, they are correctly programmed at the requested addresses without having any effects on the other bytes of the same page. /CS must be driven high after the eighth bit of the last data byte has been latched in; otherwise the Page Program instruction is not executed.

As soon as /CS is driven high, the self-timed Page Program cycle (whose duration is t_{PP}) is initiated. While the Page Program cycle is in progress, the Status Register may be read to check the value of the Write in Progress (WIP) bit. The Write in Progress (WIP) bit is 1 during the self-timed Page Program cycle, and is 0 when it is completed. At some unspecified time before the cycle is completed, the Write Enable Latch bit is reset.

A Page Program instruction applied to a page which is protected by the Block Protect (BP4, BP3, BP2, BP1, BP0) bits (see [Table 5&6](#)) is not executed.

Figure 34. Page Program Sequence Diagram

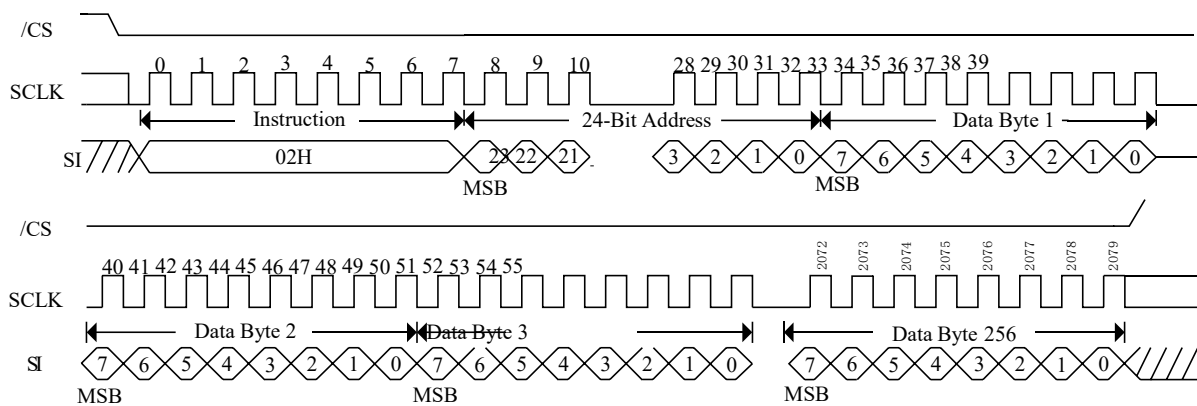

7.4.2 Quad Page Program (32H)

The Quad Page Program instruction is for programming the memory using for pins: IO0, IO1, IO2 and IO3. To use Quad Page Program the Quad enable in status register Bit9 must be set (QE=1). A Write Enable instruction must previously have been executed to set the Write Enable Latch bit before sending the Page Program instruction. The Quad Page Program instruction is entered by driving /CS Low, followed by the command code (32H), three address bytes and at least one data byte on IO pins.

The instruction sequence is shown in [Figure 35](#). If more than 256 bytes are sent to the device, previously latched data are discarded and the last 256 data bytes are guaranteed to be programmed correctly within the same page. If less than 256 data bytes are sent to device, they are correctly programmed at the requested addresses without having any effects on the other bytes of the same page. /CS must be driven high after the eighth bit of the last data byte has been latched in; otherwise the Quad Page Program instruction is not executed.

As soon as /CS is driven high, the self-timed Quad Page Program cycle (whose duration is t_{PP}) is initiated. While the Quad Page Program cycle is in progress, the Status Register may be read to check the value of the Write in Progress (WIP) bit. The Write In Progress (WIP) bit is 1 during the self-timed Quad Page Program cycle, and is 0 when it is completed. At some unspecified time before the cycle is completed, the Write Enable Latch bit is reset. A Quad Page Program instruction applied to a page which is protected by the Block Protect (BP4, BP3, BP2, BP1, BP0) bits (see [Table 5&6](#)) is not executed

Figure 35. Quad Page Program Sequence Diagram

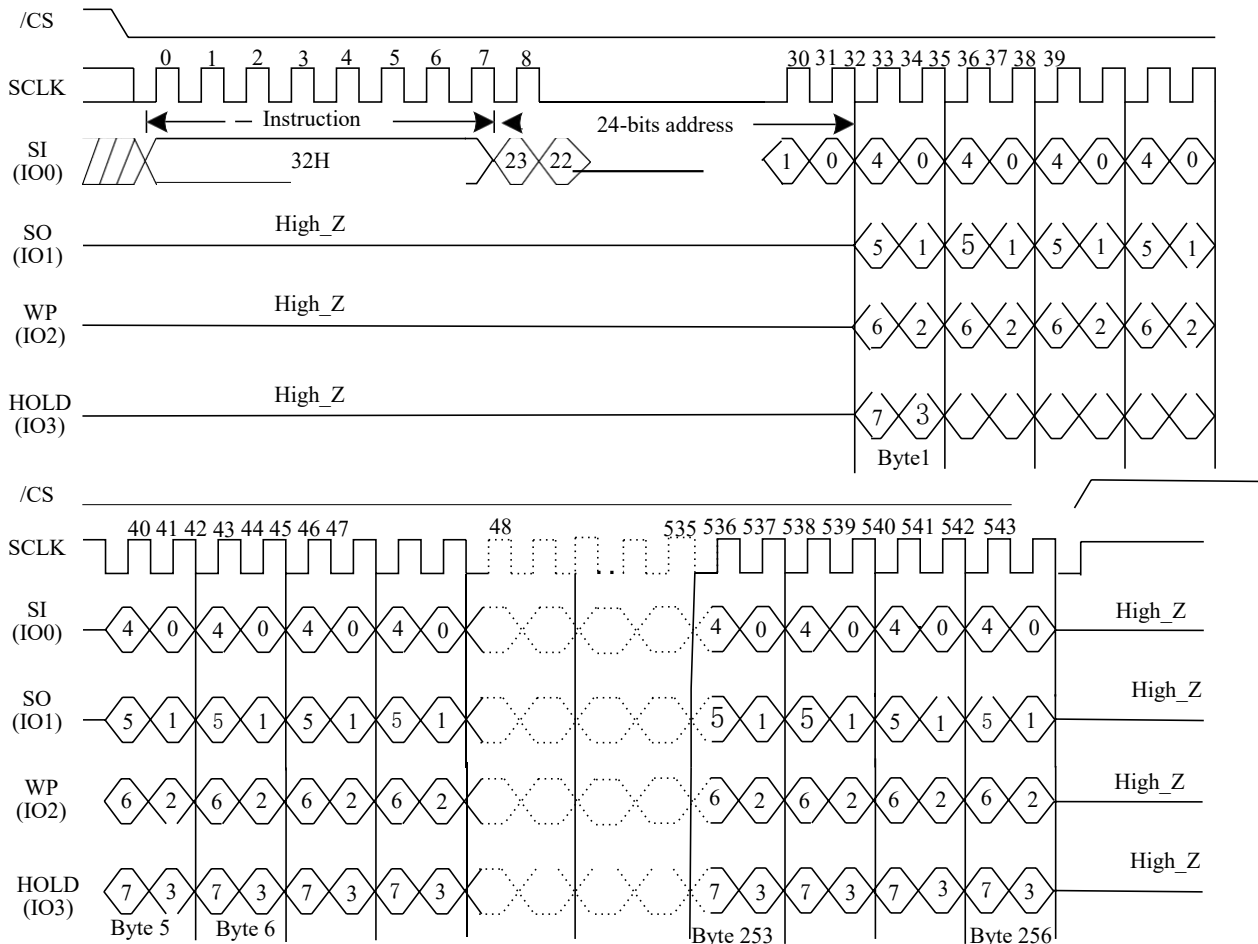

7.4.3 Fast Page Program (F2H)

The Fast Page Program instruction is used to program the memory. A Write Enable instruction must previously have been executed to set the Write Enable Latch bit before sending the Page Program instruction.

The Fast Page Program instruction is entered by driving /CS Low, followed by the instruction code, 3-byte address and at least one data byte on SI. If the 8 least significant address bits (A7-A0) are not all zero, all transmitted data that goes beyond the end of the current page are programmed from the start address of the same page (from the address whose 8 least significant bits (A7-A0) are all zero). /CS must be driven low for the entire duration of the sequence.

The Fast Page Program instruction sequence: /CS goes low -> sending Page Program instruction-> 3-byte address on SI-> at least 1 byte data on SI ->/CS goes high.

The command sequence is shown in [Figure 36](#). If more than 256 bytes are sent to the device, previously latched data are discarded and the last 256 data bytes are guaranteed to be programmed correctly within the same page. If less than 256 data bytes are sent to device, they are correctly programmed at the requested addresses without having any effects on the other bytes of the same page. /CS must be driven high after the eighth bit of the last data byte has been latched in; otherwise the Fast Page Program instruction is not executed.

As soon as /CS is driven high, the self-timed Page Program cycle (whose duration is tPP) is initiated. While the Page Program cycle is in progress, the Status Register may be read to check the value of the Write in Progress (WIP) bit. The Write In Progress (WIP) bit is 1 during the self-timed Page Program cycle, and is 0 when it is completed. At some unspecified time before the cycle is completed, the Write Enable Latch bit is reset.

A Fast Page Program instruction applied to a page which is protected by the Block Protect (BP4, BP3, BP2, BP1, BP0) bits (see [Table 5&6](#)) is not executed.

Figure 36.Fast Page Program Sequence Diagram

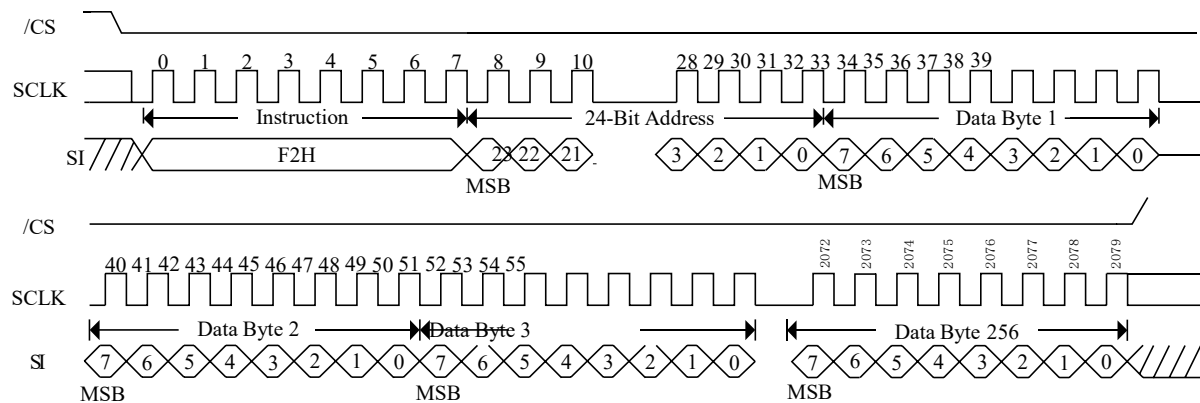

7.4.4 Sector Erase (20H)

The Sector Erase instruction is for erasing the all data of the chosen sector. A Write Enable instruction must previously have been executed to set the Write Enable Latch bit. The Sector Erase instruction is entered by driving /CS low, followed by the instruction code, and 3-address byte on SI. Any address inside the sector is a valid address for the Sector Erase instruction. /CS must be driven low for the entire duration of the sequence.

See [Figure 37](#), The Sector Erase instruction sequence: /CS goes low-> sending Sector Erase instruction-> 3-byte address on SI ->/CS goes high. /CS must be driven high after the eighth bit of the last address byte has been latched in; otherwise the Sector Erase instruction is not executed. As soon as /CS is driven high, the self-timed Sector Erase cycle (whose duration is tSE) is initiated. While the Sector Erase cycle is in progress, the Status Register may be read to check the value of the Write in Progress (WIP) bit. The Write in Progress (WIP) bit is 1 during the self-timed Sector Erase cycle, and is 0 when it is completed. At some unspecified time before the cycle is completed, the Write Enable Latch bit is reset. A Sector Erase instruction applied to a sector which is protected by the Block Protect (BP4, BP3, BP2, BP1, BP0) bits (see [Table 5&6](#)) is not executed.

Figure 37. Sector Erase Sequence Diagram

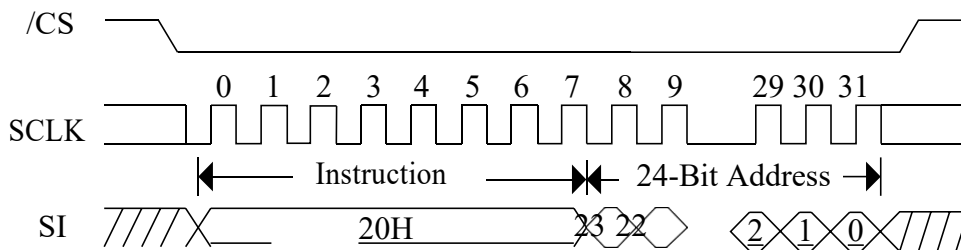

7.4.5 32KB Block Erase (52H)

The 32KB Block Erase instruction is for erasing the all data of the chosen block. A Write Enable instruction must previously have been executed to set the Write Enable Latch bit. The 32KB Block Erase instruction is entered by driving /CS low, followed by the instruction code, and 3-byte address on SI. Any address inside the block is a valid address for the 32KB Block Erase instruction. /CS must be driven low for the entire duration of the sequence.

See [Figure 38](#), the 32KB Block Erase instruction sequence: /CS goes low -> sending 32KB Block Erase instruction -> 3-byte address on SI -> /CS goes high. /CS must be driven high after the eighth bit of the last address byte has been latched in; otherwise the 32KB Block Erase instruction is not executed. As soon as /CS is driven high, the self-timed Block Erase cycle (whose duration is tBE) is initiated. While the Block Erase cycle is in progress, the Status Register may be read to check the value of the Write in Progress (WIP) bit. The Write In Progress (WIP) bit is 1 during the self-timed Block Erase cycle, and is 0 when it is completed. At some unspecified time before the cycle is completed, the Write Enable Latch bit is reset. A 32KB Block Erase instruction applied to a block which is protected by the Block Protect (BP4, BP3, BP2, BP1, BP0) bits (see [Table 5&6](#)) is not executed.

Figure 38. 32KB Block Erase Sequence Diagram

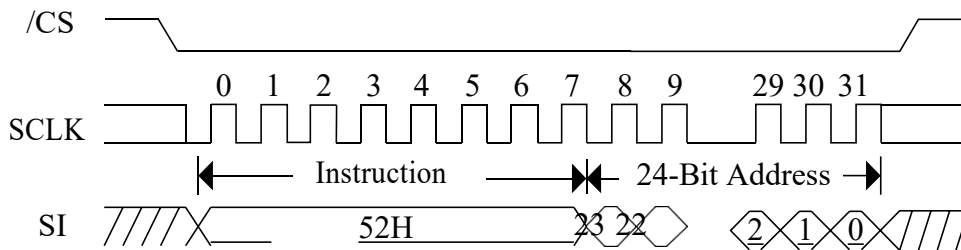

7.4.6 64KB Block Erase (D8H)

The 64KB Block Erase instruction is for erasing the all data of the chosen block. A Write Enable instruction must previously have been executed to set the Write Enable Latch bit. The 64KB Block Erase instruction is entered by driving /CS low, followed by the instruction code, and 3-byte address on SI. Any address inside the block is a valid address for the 64KB Block Erase instruction. /CS must be driven low for the entire duration of the sequence.

See [Figure 39](#), the 64KB Block Erase instruction sequence: /CS goes low sending 64KB Block Erase instruction 3-byte address on SI /CS goes high. /CS must be driven high after the eighth bit of the last address byte has been latched in; otherwise the 64KB Block Erase instruction is not executed. As soon as /CS is driven high, the self-timed Block Erase cycle (whose duration is tBE) is initiated. While the Block Erase cycle is in progress, the Status Register may be read to check the value of the Write in Progress (WIP) bit. The Write in Progress (WIP) bit is 1 during the self-timed Block Erase cycle, and is 0 when it is completed. At some unspecified time before the cycle is completed, the Write Enable Latch bit is reset. A 64KB Block Erase instruction applied to a block which is protected by the Block Protect (BP4, BP3, BP2, BP1, BP0) bits (see [Table 5&6](#)) is not executed.

Figure 39 64KB Block Erase Sequence Diagram

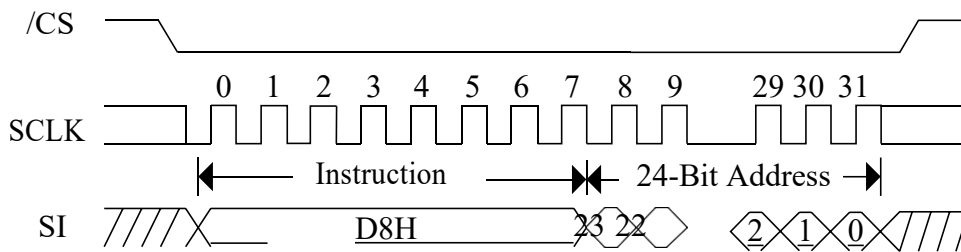

7.4.7 Chip Erase (60/C7H)

The Chip Erase instruction sets all memory within the device to the erased state of all 1s (FFh). A Write Enable instruction must be executed before the device will accept the Chip Erase Instruction (Status Register bit WEL must equal 1). The instruction is initiated by driving the /CS pin low and shifting the instruction code “C7h” or “60h”. The Chip Erase instruction sequence is shown in [Figure 40](#).

The /CS pin must be driven high after the eighth bit has been latched. If this is not done the Chip Erase instruction will not be executed. After /CS is driven high, the self-timed Chip Erase instruction will commence for a time duration of tCE. While the Chip Erase cycle is in progress, the Read Status Register instruction may still be accessed to check the status of the WIP bit.

The WIP bit is a 1 during the Chip Erase cycle and becomes a 0 when finished and the device is ready to accept other Instructions again. After the Chip Erase cycle has finished the Write Enable Latch (WEL) bit in the Status Register is cleared to 0. The Chip Erase instruction is executed only if all Block Protect (BP2, BP1, and BP0) bits are 0. The Chip Erase instruction is ignored if one or more sectors are protected.

Figure 40. Chip Erase Sequence Diagram

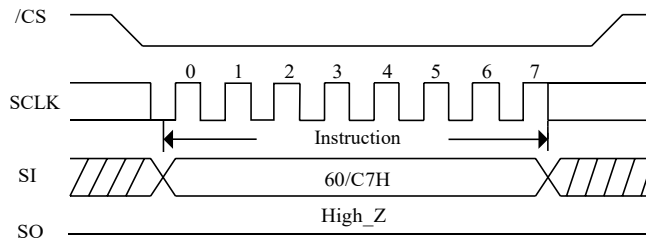

7.4.8 Erase / Program Suspend (75H)

The Erase/Program Suspend instruction allows the system to interrupt a Sector or Block Erase operation, then read from or program data to any other sector. The Erase/Program Suspend instruction also allows the system to interrupt a Page Program operation and then read from any other page or erase any other sector or block. The Erase/Program Suspend instruction sequence is shown in [Figure 41](#)

The Write Status Registers instruction (01h) and Erase instructions (20h, D8h, C7h, 60h, 44h) are not allowed during Erase Suspend. Erase Suspend is valid only during the Sector or Block erase operation. If written during the Chip Erase operation, the Erase Suspend instruction is ignored. The Write Status Registers instruction (01h), and Program instructions (02h, 42h) are not allowed during Program Suspend. Program Suspend is valid only during the Page Program operation.

Figure 41. Erase/Program Suspend Command Sequence

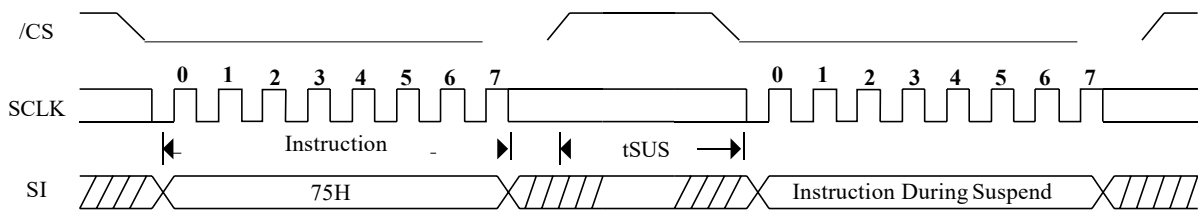

7.4.9 Erase / Program Resume (7AH)

The Erase/Program Resume instruction “7Ah” must be written to resume the Sector or Block Erase operation or the Page Program operation after an Erase/Program Suspend. The Resume instruction “7AH” will be accepted by the device only if the SUS bit in the Status Register equals to 1 and the WIP bit equals to 0.

After the Resume instruction is issued the SUS bit will be cleared from 1 to 0 immediately, the WIP bit will be set from 0 to 1 within 200 ns and the Sector or Block will complete the erase operation or the page will complete the program operation. If the SUS bit equals to 0 or the WIP bit equals to 1, the Resume instruction “7Ah” will be ignored by the device. The Erase/Program Resume instruction sequence is shown in [Figure 42](#)

Figure 42. Erase/Program Resume Command Sequence

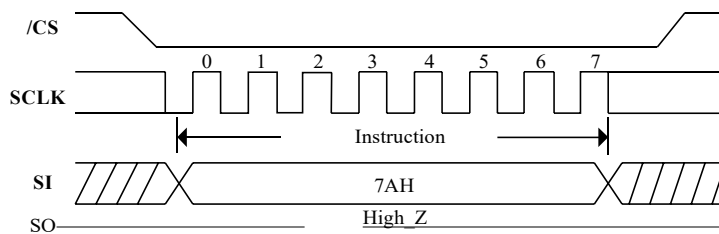

8. Electrical Characteristics

8.1 Absolute Maximum Ratings

PARAMETERS	SYMBOL	CONDITIONS	RANGE	UNIT
Supply Voltage	VCC		-0.5 to 4	V
Voltage Applied to Any Pin	VIO	Relative to Ground	-0.5 to 4	V
Transient Voltage on any Pin	VIOT	<20nS Transient Relative to Ground	-2.0V to VCC+2.0V	V
Storage Temperature	TSTG		-65 to +150	°C
Electrostatic Discharge Voltage	VESD	Human Body Model ⁽¹⁾	-2000 to +2000	V

Notes:

1. JEDEC Std JESD22-A114 (C1=100pF, R1=1500 ohms, R2=500 ohms)

8.2 Operating Ranges

PARAMETER	SYMBOL	CONDITIONS	SPEC		UNIT
			MIN	MAX	
Supply Voltage	VCC		2.7	3.6	V
Temperature Operating	TA	Commercial	0	+70	°C
		Industrial	-40	+85	

8.3 Data Retention and Endurance

Parameter	Test Condition	Min	Units
Minimum Pattern Data Retention Time	150°C	10	Years
	125°C	20	Years
Erase/Program Endurance	-40 to 85°C	100K	Cycles

8.4 Latch Up Characteristics

Parameter	Min	Max
Input Voltage Respect To VSS On I/O Pins	-1.0V	VCC+1.0V
VCC Current	-100mA	100mA

8.5 Power-up Timing

Symbol	Parameter	Min	Max	Unit
tVSL	VCC(min) To /CS Low	300		us

Figure 44. Power-up Timing and Voltage Levels

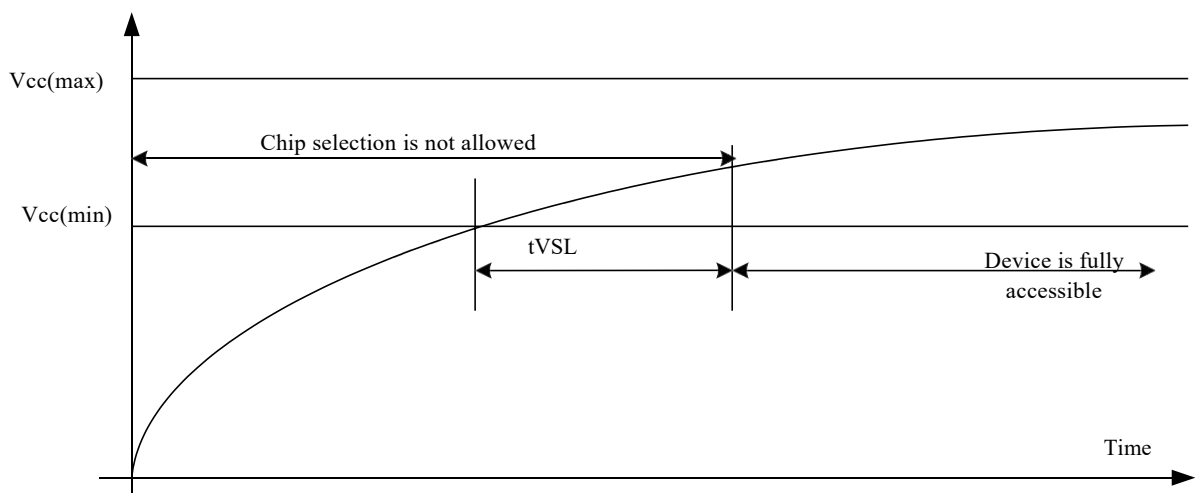

8.6 DC Electrical Characteristics

(T= -40°C~85°C, VCC=2.7~3.6V)

Symbol	Parameter	Test Condition	Min.	Typ	Max.	Unit.
ILI	Input Leakage Current				±2	μA
ILO	Output Leakage Current				±2	μA
ICC1	Standby Current	/CS=VCC, VIN=VCC or VSS		13	25	μA
ICC2	Deep Power-Down Current	/CS=VCC, VIN=VCC or VSS		2	5	μA
ICC3	Operating Current: (Read)	SCLK=0.1VCC/ 0.9VCC, at 120MHz,Q=Open(*1,*,2*4 I/O)		15	20	mA
		SCLK=0.1VCC/ 0.9VCC, at 80MHz,Q=Open(*1,*,2*4 I/O)		13	18	mA
ICC4	Operating Current(Page Program)	/CS=VCC			15	mA
ICC5	Operating Current(WRSR)	/CS=VCC			5	mA
ICC6	Operating Current(Sector Erase)	/CS=VCC			20	mA
ICC7	Operating Current(Block Erase)	/CS=VCC			20	mA
ICC8	Operating Current (Chip Erase)	/CS=VCC			20	mA
VIL	Input Low Voltage		-0.5		0.2VCC	V
VIH	Input High Voltage		0.8VCC		VCC+0.4	V
VOL	Output Low Voltage	IOL =100μA			0.4	V
VOH	Output High Voltage	IOH =-100μA	VCC-0.2			V

8.7 AC Measurement Conditions

Symbol	Parameter	Min	Typ	Max	Unit	Conditions
CL	Load Capacitance			30	pF	
TR, TF	Input Rise And Fall time			5	ns	
VIN	Input Pause Voltage	0.2VCC to 0.8VCC			V	
IN	Input Timing Reference Voltage	0.5VCC			V	
OUT	Output Timing Reference Voltage	0.5VCC			V	

Figure 45. AC Measurement I/O Waveform

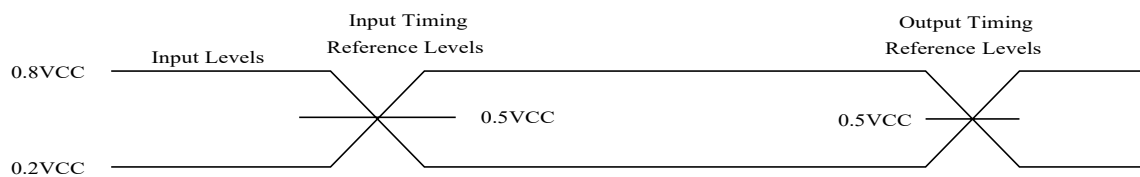

8.8 AC Electrical Characteristics

Symbol	Parameter	Min.	Typ.	Max.	Unit.
F _c	Clock frequency for all instructions, except Read Data(03H).	DC.		108	MHz
f _R	Clock freq. for Read Data instruction (03H).	DC.		55	MHz
t _{CLH}	Serial Clock High Time	4			ns
t _{CLL}	Serial Clock Low Time	4			ns
t _{CLCH}	Serial Clock Rise Time (Slew Rate)	0.1 ⁽¹⁾			V/ns
t _{CHCL}	Serial Clock Fall Time (Slew Rate)	0.1 ⁽¹⁾			V/ns
t _{SLCH}	/CS Active Setup Time	5			ns
t _{CHSH}	/CS Active Hold Time	5			ns
t _{SHCH}	/CS Not Active Setup Time	5			ns
t _{CHSL}	/CS Not Active Hold Time	5			ns
t _{SHSL}	/CS High Time (read/write)	20			ns
t _{SHQZ}	Output Disable Time			6	ns
t _{CLQX}	Output Hold Time	0			ns
t _{DVCH}	Data In Setup Time	2			ns
t _{CHDX}	Data In Hold Time	2			ns
t _{HLCH}	/Hold Low Setup Time (relative to Clock)	5			ns
t _{HHCH}	/Hold High Setup Time (relative to Clock)	5			ns
t _{CHHL}	/Hold High Hold Time (relative to Clock)	5			ns
t _{CHHH}	/Hold Low Hold Time (relative to Clock)	5			ns
t _{HLQZ}	/Hold Low To High-Z Output			6	ns
t _{HHQX}	/Hold Low To Low-Z Output			6	ns

tCLQV	Clock Low To Output Valid			7	ns
tWHSL	Write Protect Setup Time Before /CS Low	20			ns
tSHWL	Write Protect Hold Time After /CS High	100			ns
tDP	/CS High To Deep Power-Down Mode			20	μs
tRES1	/CS High To Standby Mode Without Electronic Signature Read			20	μs
tRES2	/CS High To Standby Mode With Electronic Signature Read			20	μs
tSUS	/CS High To Next Instruction After Suspend			20	μs
tRST_R	/CS High To Next Instruction After Reset(from read)			20	
tRST_P	/CS High To Next Instruction After Reset(from program)			20	
tRST_E	/CS High To Next Instruction After Reset(from erase)			12	
tW	Write Status Register Cycle Time		5	30 ⁽²⁾	ms
tBP1	Byte Program Time (First Byte) ⁽³⁾		30	50	μs
tBP2	Additional Byte Program Time (After First Byte) ⁽³⁾		2.5	12	μs
tPP	Page Programming Time		0.6	2.4	ms
tSE	Sector Erase Time		50	300	ms
tBE	Block Erase Time(32K Bytes/64K Bytes)		0.15/ 0.25	1.6/ 2	S
tCE	Chip Erase Time		25	60	S

Note:

1. Tested with clock frequency lower than 50 MHz.
2. For multiple bytes after first byte within a page, $tBP_n = tBP_1 + tBP_2 * N$, where N is the number of bytes programmed.

Figure 46. Serial inputTiming

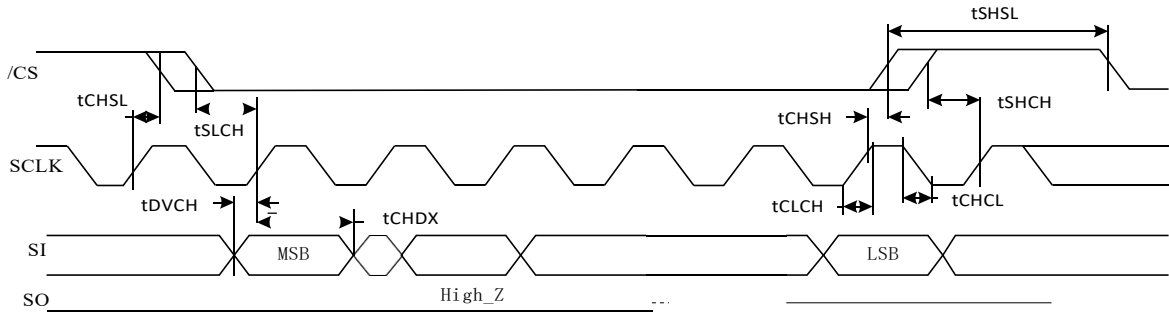

Figure 47. Output Timing

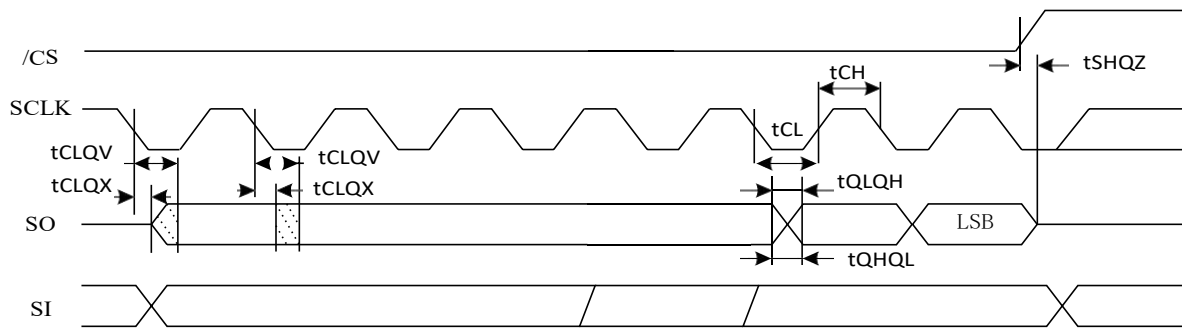

Figure 48. Hold Timing

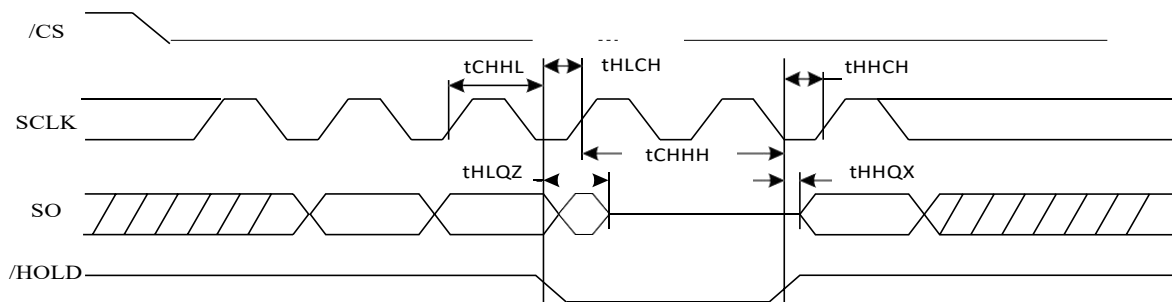
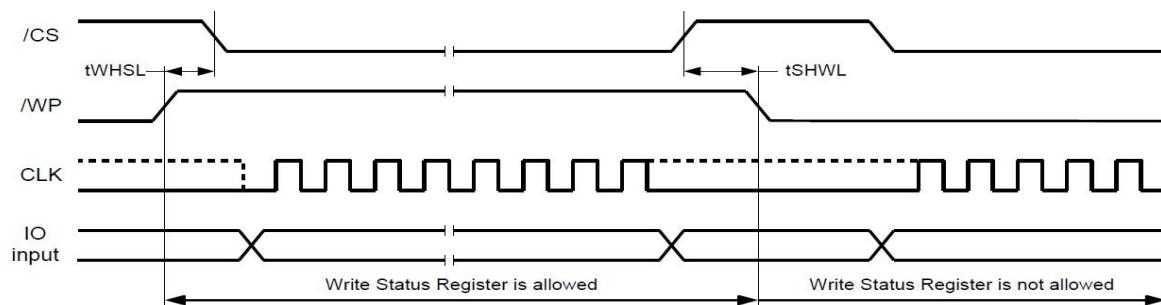
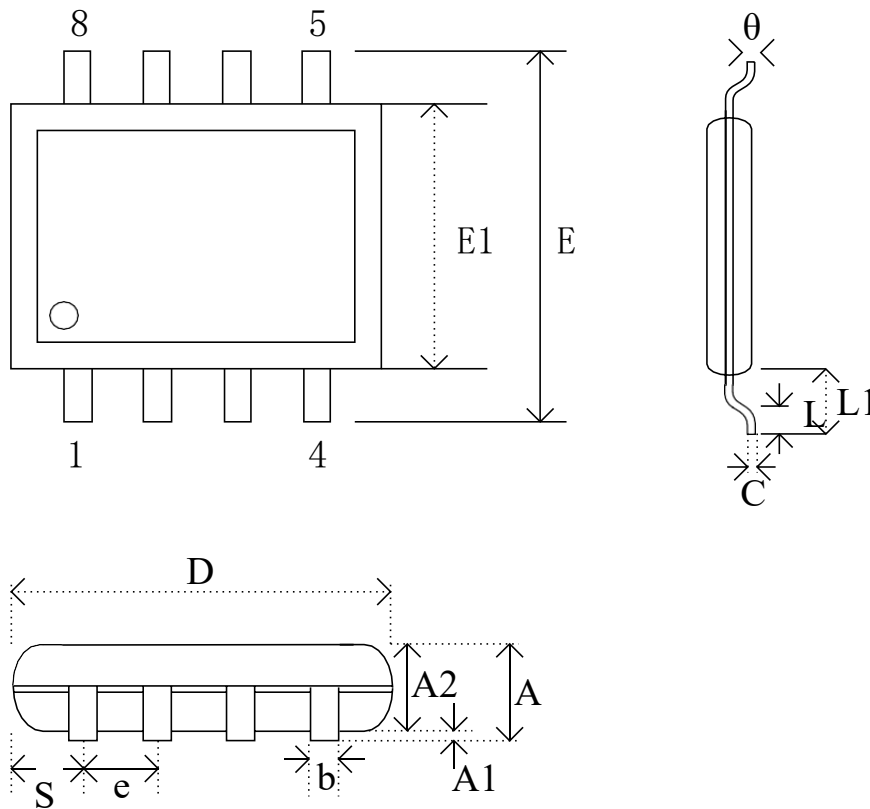

Figure 49. /WP Timing



9. Package Information

9.1 Package 8-Pin SOP 150-mil



Dimensions

Symbol		A	A1	A2	b	C	D	E	E1	e	L	L1	S	θ
Unit														
mm	Min	-	0.10	1.30	0.39	0.20	4.80	5.80	3.80	1.27	0.50	1.05	0.41	0
	Nom	-	-	1.40	-	-	4.90	6.00	3.90		-		0.54	5
	Max	1.75	0.225	1.50	0.47	0.24	5.00	6.20	4.00		0.80		0.67	8

9.2 Package 8-Pin SOP 208-mil

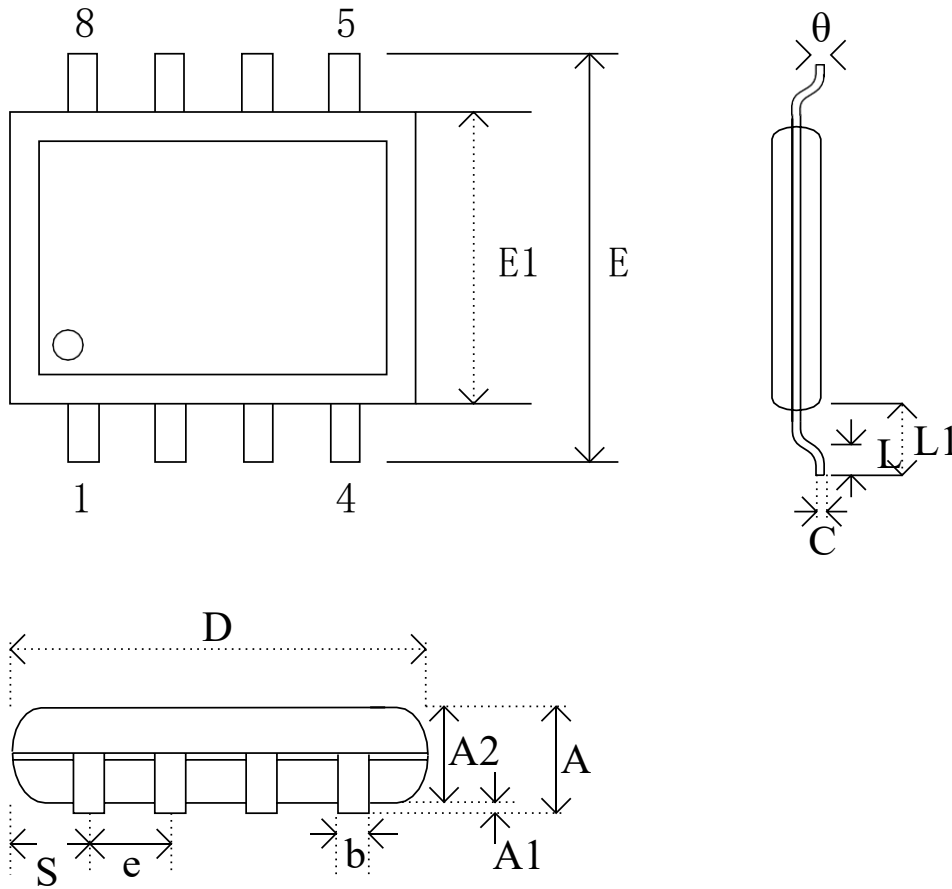

Dimensions

Symbol		A	A1	A2	b	C	D	E	E1	e	L	L1	S	ø
Unit														
mm	Min	-	0.10	1.75	0.42	0.20	5.00	7.85	5.16	1.27	0.60	1.31	0.62	mm
	Nom	-	0.15	1.80	-	-	5.17	7.90	5.22	1.27	0.65	1.31	0.74	5
	Max	1.95	0.18	1.90	0.48	0.24	5.25	7.98	5.26		0.70	1.41	0.88	8

9.3 Package 8-Pad WSON (6x5mm)

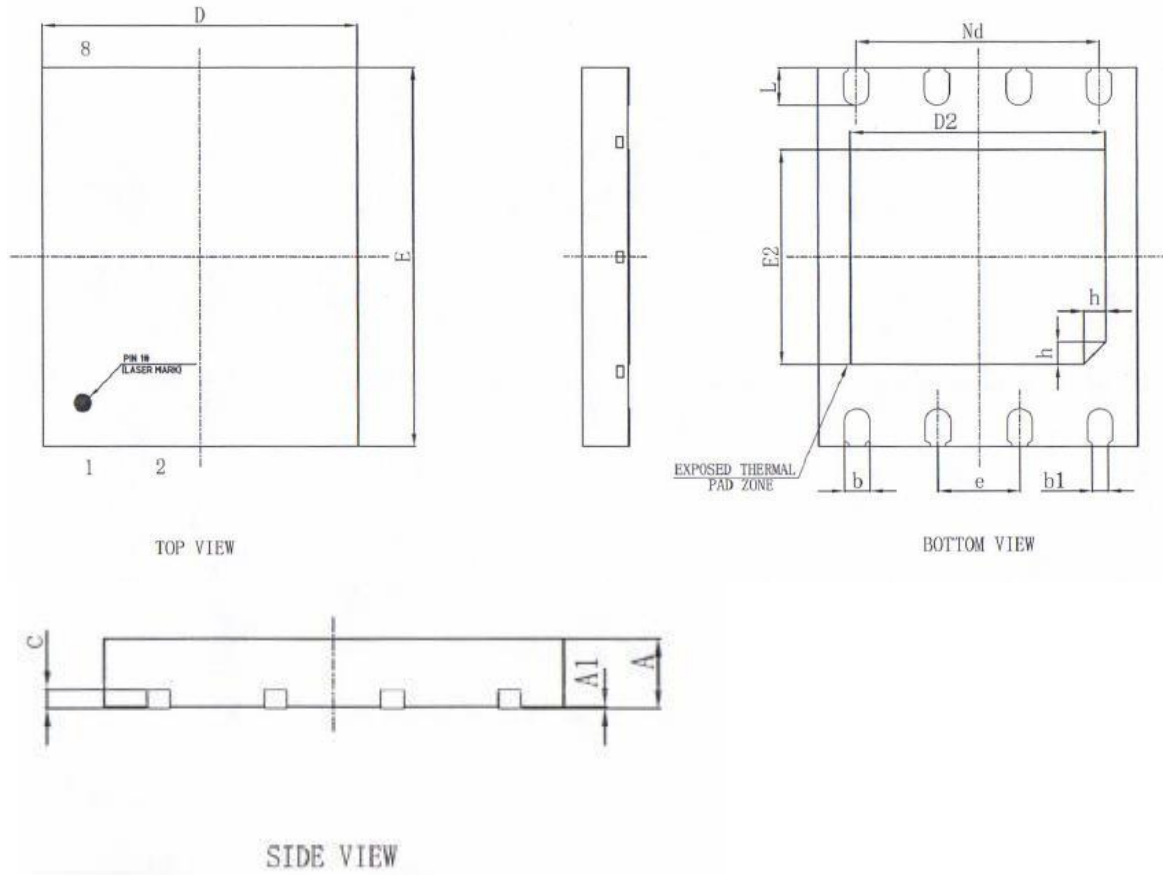

Dimensions

Symbol		A	A1	b	b1	c	D	Nd	e	E	D2	E2	L	h
Unit														
mm	Min	0.70	0	0.35	0.25REF	0.18	4.90	3.81BSC	1.27BSC	5.90	3.90	3.30	0.55	0.30
	Nom	0.75	0.02	0.40		0.203	5.00			6.00	4.00	3.40	0.60	0.35
	Max	0.80	0.05	0.45		0.25	5.10			6.10	4.10	3.50	0.65	0.40

9.4 Package USON8 (4*3mm)

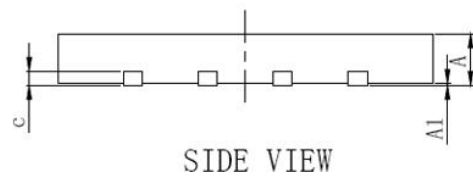
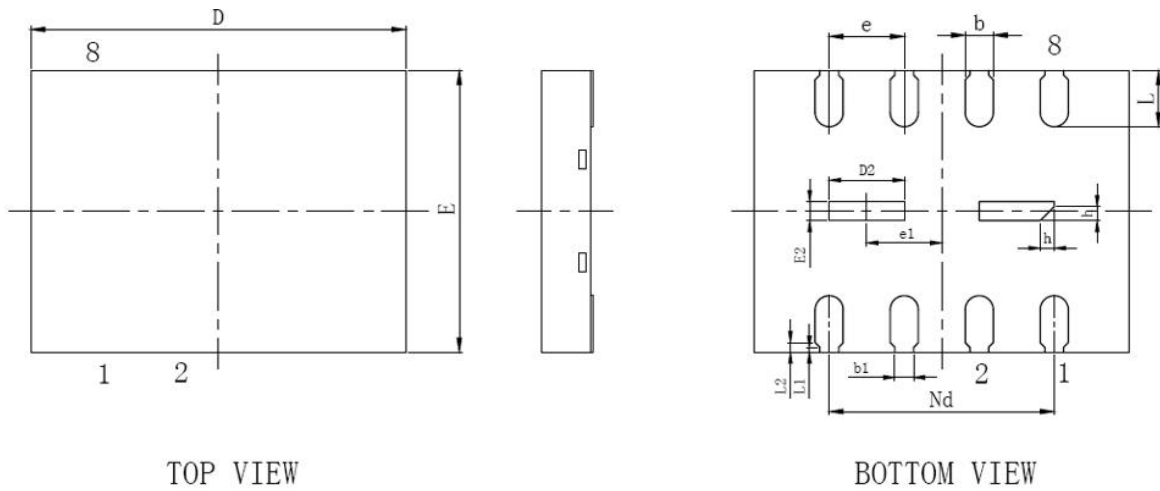

Dimensions

Symbol		A	A1	b	b1	c	D	D2	e
Unit									
mm	Min	0.4	0	0.25	0.2REF	0.1	3.9	0.7	0.8BSC
	Nom	0.45	0.02	0.3		0.15	4	0.8	
	Max	0.5	0.05	0.35		0.2	4.1	0.9	
Symbol		e1	Nd	E	E2	L	L1	L2	h
Unit									
mm	Min	0.8BSC	2.4BSC	2.9	0.1	0.55	0.05REF	0.10REF	0.1
	Nom			3	0.2	0.6			0.15
	Max			3.1	0.3	0.65			0.2

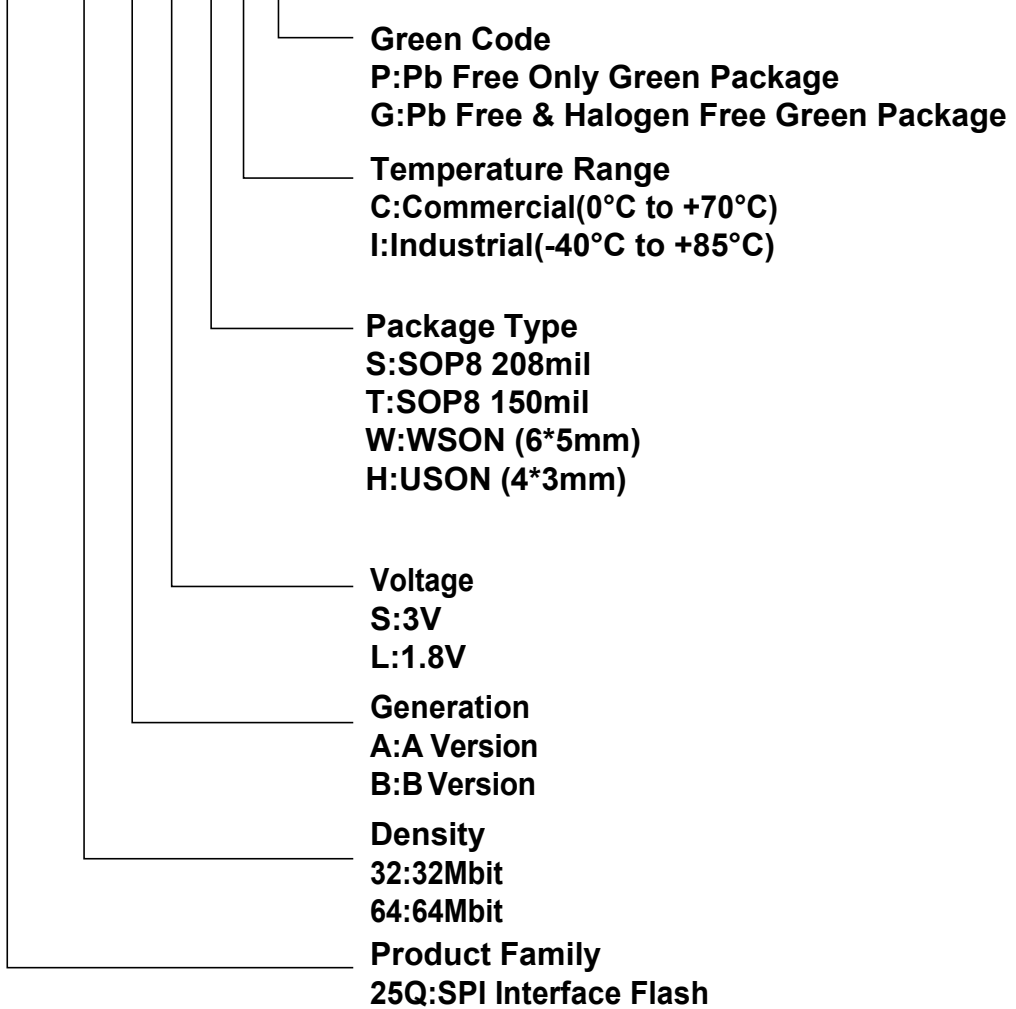

10. Order Information

BY 25Q 64 A S S I G

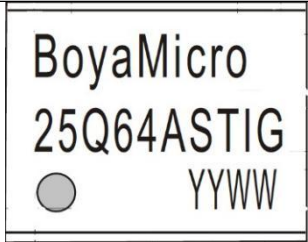

10.1 Valid part Numbers and Top Side Marking

The following table provides the valid part numbers for BY25Q64AS SPI Flash Memory. Pls contact BoyaMicro for specific availability by density and package type.

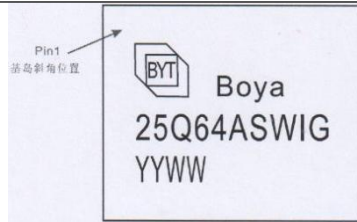
Package Type	Density	Product Number	Top Side Marking
S SOP8 208mil	64M-bit	BY25Q64ASSIG	
T SOP8 150mil	64M-bit	BY25Q64ASTIG	
H USON8 4*3mm	64M-bit	BY25Q64ASHIG	
W WSON8 6*5mm	64M-bit	BY25Q64ASWIG	

10.2 Minimum Packing Quantity (MPQ)

Package Type	Packing Type	Qty for 1 Tube or Reel	Vacuum bag/ Inner Box	MPQ
SOP8 150mil	Tube	100ea/Tube	100Tubes/Bag 1Bag/InnerBox	10,000
	Tape&Reel (13inch, 12mm)	4000ea/Reel	1Reel/Bag 1Bags/InnerBox	4,000
SOP8 208mil	Tube	95ea/Tube	100Tubes/Bag 1Bag/InnerBox	9,500
	Tape&Reel (13inch, 16mm)	2000ea/Reel	1Reel/Bag 2Bags/InnerBox	4,000
WSON8 6*5mm	Tape&Reel (13inch)	3000ea/Reel	1Reel/Bag 1Bag/InnerBox	3,000
DFN8 4*3mm	Tape&Reel (13inch)	3000ea/Reel	1Reel/Bag 1Bag/InnerBox	3,000

11. Document Change History

Doc. Rev.	Tech Dev. Rev.	Effective Date	Change Description
1.0		2017-8-7	Initiate
1.1		2019-4-27	1,Update WSON 5*6 POD 2,Add MPQ Information
1.2		2019-5-24	Update USON8 (4*3mm) package information